



**MX1-Au FIRE ALARM SYSTEM
System Design Manual**

Document Number: LT0441
Issue 1.82
20 September 2022

MX1 is manufactured by:

Johnson Controls
17 Mary Muller Drive
Hillsborough
Christchurch 8022
NEW ZEALAND

Tel: + 64 – 3 – 389-5096

© 2022. Johnson Controls. All rights reserved. All specifications and other information shown were current as of document revision date and are subject to change without notice.

Warning Symbols Used in this Manual



Danger! Failure to comply may lead to serious injury and/or property damage.



Caution – failure to comply may result in incorrect, unpredictable or unstable operation.



Indicates important information.



End User Liability Disclaimer

The *MX1* Fire Indicator Panel provides a configuration programming facility which may be accessed via a programming terminal using a password. Because this programming facility allows the user to define in detail the operation of the *MX1* System being customised, changes may be made by the user that prevent this installation from meeting statutory requirements.

Johnson Controls does not accept responsibility for the suitability of the functions programmed by the user.



Electromagnetic Compatibility

This is a Class A product. In a domestic environment this product may cause radio interference in which case the user may be required to take adequate measures.



Firmware Compatibility

Except where otherwise stated, this manual refers to *MX1* Controller firmware version 1.81. Information provided in this manual may remain valid for different versions of Controller firmware. However if a different version of firmware is installed, a more appropriate version of this manual may be required.

Trademarks

VESDA is a registered trademark of Xtralis Pty Ltd.

MX DIGITAL, *SMARTSENSE*, *MX FASTLOGIC*, *MX TECHNOLOGY*, *MX VIRTUAL* and *VIGILANT* are trademarks of Johnson Controls.

Non-Disclosure Agreement

Johnson Controls (THE COMPANY) and the User of this/these document(s) desire to share proprietary technical information concerning electronic systems.

For this reason the company is disclosing to the User information in the form of this/these document(s). In as much as the company considers this information to be proprietary and desires that it be maintained in confidence, it is hereby agreed by the User that such information shall be maintained in confidence by the User for a period of TEN YEARS after the issue date and only be used for the purpose for which it was supplied.

During this period, the User shall not divulge such information to any third party without the prior written consent of the company and shall take reasonable efforts to prevent any unauthorised disclosure by its employees. However, the User shall not be required to keep such information in confidence if it was in their possession prior to its receipt from the company; if it is or becomes public knowledge without the fault of the User; or the information becomes available on an unrestricted basis from a third party having a legal right to disclose such information.

The User's receipt and retention of this information constitutes acceptance of these terms.

This information is copyright and shall not be reproduced in any form whatsoever.

Table of Contents

1	<u>SCOPE</u>	1-1
1.1	SCOPE	1-2
2	<u>SYSTEM OVERVIEW</u>	2-1
2.1	GENERAL DESCRIPTION	2-2
2.1.1	DETECTORS AND DEVICES	2-2
2.1.2	DISPLAYS	2-2
2.1.3	OUTPUTS	2-2
2.1.4	POWER SUPPLY	2-2
2.1.5	REMOTE DISPLAYS	2-2
2.1.6	LOGGING PRINTER	2-3
2.1.7	REMOTE ACCESS	2-3
2.1.8	NETWORKING	2-3
2.1.9	FIRE FAN CONTROL PANELS AND DISTRIBUTED SWITCH SYSTEM	2-3
2.2	SYSTEM STRUCTURE	2-3
2.3	OPERATOR ACCESS LEVELS	2-4
2.4	INTERNAL CONTROLS	2-4
2.5	DEVICE ALARM PROCESSING	2-5
2.5.1	CONVENTIONAL DETECTORS - AVF	2-5
2.5.2	ANALOGUE ADDRESSABLE DETECTORS - ALGORITHMS	2-5
2.6	ALARM INVESTIGATION FACILITY (AIF)	2-7
2.7	ALARM ACKNOWLEDGEMENT FACILITY (AAF)	2-8
2.8	ALARM DELAY FACILITY (ADF)	2-8
2.9	RESIDENTIAL INSTALLATIONS	2-8
2.10	SYSTEM OPERATION	2-8
2.11	SID	2-9
2.12	POINTS	2-9
2.12.1	POINT STATES	2-9
2.12.2	POINT VALUES	2-10
2.12.3	POINT NUMBERING	2-10
2.13	ZONES	2-11
2.13.1	MAPPING POINTS TO ZONES	2-11
2.13.2	ZONE STATES	2-12
2.13.3	ZONE GROUPS	2-12
2.14	SYSTEM PROCESSING	2-12
3	<u>SYSTEM SPECIFICATIONS</u>	3-1
3.1	GENERAL SPECIFICATIONS	3-2
3.1.1	ORDERING CODES	3-2
3.1.2	STANDARDS	3-2
3.1.3	CABINETS	3-3
3.2	ENVIRONMENTAL OPERATION CONDITIONS	3-4
3.3	ELECTRICAL SUPPLY REQUIREMENTS	3-4
3.4	INPUTS	3-5
3.5	OUTPUTS	3-6
3.6	COMMUNICATION PORTS	3-7
3.7	EXTERNAL CONTROLS	3-8
3.8	INTERNAL CONTROLS	3-8
3.9	DISPLAYS	3-9
3.10	OTHER OPTIONAL MODULES	3-10

4	SYSTEM DESIGN PROCEDURE	4-1
4.1	GENERAL	4-2
4.2	MX1 SYSTEM OPERATION	4-2
4.2.1	COMPONENTS AFFECTING BASIC SYSTEM OPERATION	4-2
4.2.2	SYSTEM PROFILE-CONTROLLED MX1 OPERATION	4-2
4.2.3	INDIVIDUAL SETTINGS FOR MX1 OPERATION	4-3
4.3	DETECTORS	4-3
4.4	INTRINSICALLY SAFE DETECTORS	4-3
4.5	ALARM DEVICES	4-4
4.6	ANCILLARY LOADS AND OTHER DEVICES	4-4
4.7	ZONE DISPLAYS – ALPHANUMERIC AND INDIVIDUAL	4-4
4.8	REMOTE ZONE DISPLAYS	4-5
4.9	ALARM ROUTING/BRIGADE SIGNALLING	4-5
4.10	MX LOOP CARD	4-5
4.11	BATTERY REQUIREMENTS	4-5
4.12	USER LOGIC FOR CUSTOM CONTROL	4-6
4.13	PROFILES	4-6
4.14	NETWORKING	4-6
4.15	FIRE FAN CONTROL PANELS AND DISTRIBUTED SWITCH SYSTEM	4-6
5	MX DEVICES	5-1
5.1	DEVICE TYPES	5-2
5.1.1	850 SERIES DETECTORS	5-5
5.2	DEVICE INSTALLATION – MOUNTING THE DEVICES	5-5
5.2.1	DETECTORS AND DETECTOR BASES	5-5
5.2.2	MODULES	5-5
5.3	ADDRESS AND LED BLINK PROGRAMMING	5-6
5.4	DETECTOR DESCRIPTIONS	5-6
5.4.1	850H	5-6
5.4.2	850P	5-7
5.4.3	850PH	5-7
5.4.4	850PC	5-7
5.4.5	814P PHOTOELECTRIC SMOKE DETECTOR	5-8
5.4.6	814PH PHOTOELECTRIC SMOKE + HEAT DETECTOR	5-8
5.4.7	814CH CARBON MONOXIDE + HEAT DETECTOR	5-8
5.4.8	814I IONISATION SMOKE DETECTOR	5-8
5.4.9	814H HEAT DETECTOR	5-9
5.4.10	801F FLAME DETECTOR	5-9
5.4.11	VLC-800MX VESDA LASERCOMPACT	5-9
5.4.12	FV411F / FV412F / FV413F FLAME DETECTOR	5-10
5.4.13	S271F+ FLAME DETECTOR	5-10
5.5	DETECTOR ALGORITHMS	5-11
5.6	DETECTOR BASE DESCRIPTIONS	5-15
5.6.1	UNIVERSAL BASES	5-15
5.6.2	ISOLATOR BASES	5-15
5.6.3	CONTINUITY BASE	5-16
5.6.4	814RB RELAY BASE	5-16
5.6.5	802SB/812SB SOUNDER BASES	5-17
5.6.6	901SB SOUNDER BASE	5-17
5.6.7	REMOTE INDICATOR WIRING	5-17
5.6.8	80DSB SOUNDER BASE	5-18
5.6.9	P80SB ADDRESSABLE SOUNDER BASE (AAD)	5-18
5.6.10	P80AVB/P81AVB SOUNDER BEACON BASE (VAD)	5-18
5.6.11	P80AVR/P80AVW ADDRESSABLE WALL-MOUNT SOUNDER BEACON (VAD)	5-18
5.7	MODULE DESCRIPTIONS	5-19

5.7.1	MIM800 AND MIM801 MINI INPUT MODULES	5-19
5.7.2	CIM800 CONTACT INPUT MODULE	5-20
5.7.3	CP820/CP830/MCP820/MCP830 MANUAL CALL POINTS	5-22
5.7.4	DDM800 UNIVERSAL FIRE & GAS DETECTOR MODULE	5-22
5.7.5	DIM800 DETECTOR INPUT MONITOR	5-28
5.7.6	LPS800 LOOP-POWERED SOUNDER DRIVER	5-30
5.7.7	MIO800 MULTIPLE I/O MODULE	5-32
5.7.8	RIM800 RELAY INTERFACE MODULE	5-34
5.7.9	SAB801 & SAM800	5-34
5.7.10	SNM800 SOUNDER NOTIFICATION MODULE	5-34
5.7.11	QIO850 / QMO850 / QRM850 QUAD ANCILLARY MODULES	5-35
5.7.12	SIO800 SINGLE INPUT/OUTPUT MODULE	5-39
5.8	OTHER DEVICES	5-40
5.8.1	LIM800	5-40
5.9	SUPERVISED POWER FEED WIRING	5-40
5.9.1	REQUIREMENTS	5-40
5.9.2	EXAMPLE APPLICATION OF SUPPLY LOOP USE	5-42
5.9.3	USING SNM800 TO CONTROL A SUPPLY LOOP WIRING	5-42
5.9.4	MIM800 WITH 814RB RELAY BASE TO CONTROL A SUPPLY LOOP WIRING	5-43
5.10	INTRINSICALLY SAFE DEVICES	5-44
5.10.1	GENERAL	5-44
5.10.2	FIRE DETECTION APPROVALS	5-44
5.10.3	CERTIFICATION FOR USE IN EXPLOSIVE ATMOSPHERES	5-44
5.10.4	QUALIFICATIONS OF PERSONNEL	5-45
5.10.5	OTHER REQUIREMENTS	5-45
5.10.6	PRODUCT APPLICATION AND DESIGN INFORMATION	5-45
5.10.7	CONNECTION TO ADDRESSABLE LOOP	5-45
5.10.8	DETECTOR BASES	5-47
5.10.9	801PHEX PHOTOELECTRIC SMOKE & HEAT DETECTOR	5-47
5.10.10	801CHEX CARBON MONOXIDE & HEAT DETECTOR	5-47
5.10.11	801HEX HEAT DETECTOR	5-47
5.10.12	801FEX FLAME DETECTOR	5-47
5.10.13	REMOTE LED & FUNCTIONAL BASE OUTPUTS	5-47
5.10.14	IF800EX INTERFACE MODULE	5-48
5.10.15	CP840EX MANUAL CALL POINT	5-48
5.10.16	S2711+ FLAME DETECTOR	5-48
5.10.17	FV4211 FLAME DETECTOR	5-49

6 **MX LOOP DESIGN** **6-1**

6.1	ANALOGUE LOOP CONFIGURATION SELECTION	6-2
6.1.1	LINES AND LOOPS	6-2
6.1.2	LOOP FAULT TOLERANCE	6-2
6.1.3	AS 1670.1:2018 DESIGN REQUIREMENTS	6-3
6.2	ANALOGUE LOOP/LINE LAYOUT	6-3
6.2.1	LINE MODE	6-3
6.2.2	LOOP DESIGN WITH SHORT CIRCUIT ISOLATORS	6-3
6.2.3	DESIGN NOTES	6-4
6.2.4	STAR CONNECTION OF LOOP WIRING	6-5
6.2.5	SPURS	6-5
6.3	CABLE SELECTION CONSIDERATIONS	6-6
6.3.1	NOISE CONSIDERATIONS	6-7
6.4	LOOP CALCULATION	6-7
6.4.1	MANUAL CALCULATION	6-7
6.4.2	LOOP ISOLATOR LIMITATIONS	6-10
6.5	LOOP LIMITS	6-10
6.5.1	DC LOAD	6-10
6.5.2	AC LOAD	6-10

6.5.3	ON-BOARD AND LOOP CARD LOOP PERFORMANCE LIMITS	6-11
6.6	INTRINSICALLY SAFE SPURS	6-11
7	<u>ALARM DEVICES</u>	<u>7-1</u>
7.1	INTRODUCTION	7-2
7.1.1	ALARM DEVICE TYPES	7-2
7.1.2	MX1 LOGIC EQUATIONS	7-2
7.1.3	100V WIRING	7-3
7.2	T- GEN2 (T-GEN 60 & T-GEN 120)	7-3
7.2.1	MOUNTING	7-3
7.2.2	WIRING	7-4
7.2.3	CONFIGURATION 1 – T-GEN2 CONTROL OF ALERTING AND EVACUATION TONE	7-6
7.2.4	CONFIGURATION 2 – MX1 CONTROL OF ALERTING AND EVACUATION TONES	7-6
7.3	T- GEN 50 (OBSOLETE – REPLACED BY T-GEN2)	7-7
7.3.1	MOUNTING	7-7
7.3.2	WIRING	7-7
7.3.3	CONFIGURATION 1 – T-GEN 50 CONTROL OF ALERTING AND EVACUATION TONES	7-8
7.3.4	CONFIGURATION 2 – MX1 CONTROL OF ALERTING AND EVACUATION TONES	7-9
7.4	MINI-GEN	7-10
7.4.1	GENERAL	7-10
7.4.2	MOUNTING	7-10
7.4.3	WIRING	7-10
7.4.4	CONFIGURATION	7-11
7.4.5	CONFIGURATION 2 – MX1 CONTROL OF ALERTING AND EVACUATION TONES	7-12
7.5	ISO STROBES	7-12
7.5.1	GENERAL	7-12
7.5.2	MOUNTING	7-12
7.5.3	WIRING	7-13
7.5.4	CONFIGURATION	7-13
7.6	SOUNDERS (AADS) AND BEACONS (VADS)	7-14
7.6.1	GENERAL	7-14
7.6.2	WIRING	7-14
7.6.3	CONFIGURATION	7-14
7.6.4	USING MX MODULES	7-14
7.7	DETECTOR SOUNDER BASES	7-15
7.8	AUDIO VISUAL INDICATOR	7-18
7.8.1	AVI WIRING	7-18
7.8.2	CONFIGURATION	7-19
7.9	BELL MONITOR BOARD	7-20
7.9.1	INTRODUCTION	7-20
7.9.2	MOUNTING	7-20
7.9.3	WIRING	7-20
7.10	QE90	7-21
7.11	T-GEN2	7-24
7.12	QE20	7-26
8	<u>MISCELLANEOUS APPLICATIONS</u>	<u>8-1</u>
8.1	GENERAL	8-2
8.2	CABINET OPTIONS	8-2
8.2.1	19" RACK CABINET OPTIONS	8-2

8.3	MX LOOP CARD	8-22
8.4	WIRING A STROBE FOR EXTERNAL ALARM	8-22
8.5	APPLICATION – CONNECTION TO SPRINKLER SYSTEMS	8-22
8.5.1	CONNECTION USING A SIO800, CIM800, OR MIM800	8-23
8.5.2	CONNECTION USING A GENERAL PURPOSE INPUT	8-24
8.5.3	CONFIGURATION OF ZONES FOR USE WITH SPRINKLERS	8-25
8.5.4	ANNUNCIATION OF FLOW SWITCH ACTIVATIONS	8-25
8.5.5	SPRINKLER SYSTEM ANNUNCIATES AS AN MX1 ALARM - MONITORING COMBINED	8-25
8.5.6	SPRINKLER SYSTEM MONITORED AS A SEPARATE ALARM	8-26
8.6	APPLICATION – FAULT MONITORING	8-27
8.7	APPLICATION - REMOTE BUZZER OUTPUT	8-28
8.7.1	WIRING	8-28
8.7.2	CONFIGURATION	8-29
8.8	APPLICATION - FAULT BUZZER CANCEL INPUT	8-29
8.8.1	WIRING	8-29
8.8.2	OPERATION	8-30
8.8.3	CONFIGURATION	8-30
8.9	APPLICATION – DOOR HOLDER CONTROL	8-30
8.9.1	WIRING	8-30
8.9.2	CONFIGURATION	8-31
8.10	APPLICATION – EVENT LOGGING PRINTER	8-31
8.10.1	WIRING	8-32
8.10.2	CONFIGURATION	8-32
8.11	APPLICATION – AVOIDING RELAY “CHATTER”	8-33
8.11.1	WIRING	8-33
8.11.2	CONFIGURATION	8-33
8.12	APPLICATION – CONTROL AND ISOLATION OF ANCILLARY OUTPUTS	8-34
8.12.1	OPTIONS FOR CONTROL OF BUILDING SERVICES	8-34
8.12.2	USING DOOR STATUS TO ENABLED OUTPUTS	8-34
8.12.3	USING ANCILLARY GROUPS	8-34
8.12.4	ANCILLARY GROUPS EXAMPLE	8-35
8.13	ALARM ROUTING FAULT INPUT	8-36
8.14	APPLICATION - GENERATING ALARMS AND FAULTS USING OUTPUT LOGIC AND PSEUDO POINTS	8-36
8.14.1	EXAMPLES	8-36
8.15	VIO800 APPLICATION FOR LASERPLUS OR LASERSCANNER	8-37
8.16	AIF CONFIGURATION	8-38
8.16.1	ALARM INVESTIGATION - DESCRIPTION AND REQUIREMENTS	8-38
8.16.2	MX1 AIF IMPLEMENTATION	8-39
8.16.3	ACKNOWLEDGE AND INVESTIGATE TIMES IN AIF ZONE PROFILE	8-39
8.16.4	ZONE CONFIGURATION	8-39
8.16.5	DETECTION CONFIGURATION	8-39
8.16.6	TRAINING REQUIREMENTS	8-40
8.16.7	OUTPUT LOGIC EQUATIONS	8-40
8.17	AAF CONFIGURATION	8-41
8.17.1	ALARM ACKNOWLEDGMENT - DESCRIPTION AND REQUIREMENTS	8-41
8.17.2	CONFIGURATION OF MX1 AAF	8-41
8.17.3	ACKNOWLEDGEMENT AND INVESTIGATION TIMES	8-42
8.17.4	CONFIGURATION OF AAF ZONES.	8-42
8.17.5	DETECTION CONFIGURATION FOR AAF OPERATION	8-43
8.17.6	TRAINING REQUIREMENTS	8-44
8.17.7	AAF OPERATION WITH NO ALARM ACKNOWLEDGEMENT FACILITY	8-44
8.18	FIRE FAN CONTROL (AS 1668) APPLICATIONS USING PUSHBUTTON FIRE FAN CONTROLS	8-44
8.18.1	INTRODUCTION	8-44
8.18.2	SUPPORTED FAN CONTROL CONFIGURATIONS	8-44
8.18.3	FFCP HARDWARE CONFIGURATION	8-47
8.18.4	PROGRAMMING THE FIRE FAN CONTROL PANEL	8-49

8.18.5	PROGRAMMING THE FFCP HARDWARE	8-50
8.18.6	PROGRAMMING A NETWORK FIRE FAN CONTROL SYSTEM	8-51
8.18.7	PROGRAMMING THE FIRE FAN CONTROL PANEL USING LOGIC BLOCKS	8-51
8.18.8	FIRE FAN CONTROL ON XLGRAPHICS	8-59
8.19	FIRE FAN CONTROL (AS 1668) APPLICATIONS USING ME0472	8-60
8.19.1	SUPPORTED FAN CONTROL CONFIGURATIONS	8-60
8.19.2	CONFIGURING MX1 FOR FAN CONTROLS	8-61
8.19.3	FAN CONTROL STATUS INDICATION EQUATIONS	8-62
8.19.4	SUPPLY AIR FAN LOGIC	8-62
8.19.5	SPILL AIR FAN LOGIC	8-62
8.19.6	RETURN AIR FAN LOGIC	8-63
8.19.7	FAN CONTROL LOGIC EXAMPLE	8-63
8.20	USING THE GP OUTPUTS	8-64
8.20.1	GENERAL	8-64
8.20.2	OUTPUTS	8-64
8.20.3	SUPERVISION MODE	8-64
8.21	USING THE LCD/KEYBOARD INPUTS & OUTPUTS	8-65
8.21.1	GENERAL	8-65
8.21.2	INPUTS	8-65
8.21.3	OUTPUTS	8-65
8.22	ADDITIONAL FUSED POWER OUTPUTS	8-66
8.23	MX1 DISTRIBUTED SWITCH SYSTEM (DSS)	8-66
8.23.1	INTRODUCTION	8-66
8.23.2	PROGRAMMING THE DSS	8-67
8.23.3	PROGRAMMING THE DSS HARDWARE	8-68
8.23.4	PROGRAMMING THE DSS USING LOGIC BLOCKS	8-68
8.23.5	PROGRAMMING THE DSS TABLE	8-74
8.23.6	PROGRAMMING THE DSS OUTPUT LOGIC	8-77
8.24	APPLICATION – ACTIVATE RELAY ON ZONE RESET	8-79
8.25	ALARM DELAY FACILITY - ADF	8-79
8.25.1	GENERAL	8-79
8.25.2	ADF DELAYS	8-80
8.25.3	CONFIGURATION OF AN ADF ZONE AND SMOKE DETECTOR	8-80
8.25.4	OVERRIDING ADF DELAYS	8-81
8.26	APPLICATION – USING D51MX DUCT SAMPLING UNIT	8-82
8.27	EXTERNAL STROBE/BELL SILENCE WITH ALARM BUZZER SILENCE	8-82
8.27.1	GENERAL	8-82
8.27.2	ZONES THAT DO NOT ACTIVATE THE ALARM BUZZER	8-83
8.27.3	HANDLING FAULTS ON STROBE OUTPUTS	8-83
8.28	POWER FAIL OUTPUT	8-84
8.28.1	GENERAL	8-84

9 PSU & BATTERY DESIGN **9-1**

9.1	PSU & BATTERY DESIGN	9-2
9.1.1	GENERAL	9-2
9.1.2	MX1COST CALCULATION TOOL	9-2
9.1.3	MAINS FAIL FAULT	9-3
9.1.4	POWER SUPPLY FAIL SIGNAL	9-3
9.2	MANUAL BATTERY CALCULATION – SYSTEM LOADS	9-4
9.2.1	BATTERY CAPACITY CALCULATION (AS 1670.1)	9-5
9.3	BATTERY HOUSING	9-6
9.4	ADDITIONAL CHARGER AND BATTERIES	9-6
9.5	POWERING FROM AN EXTERNAL DC SUPPLY	9-7

10 ZONE DISPLAY DESIGN **10-1**

10.1 GENERAL	10-2
10.2 ZONE LED DISPLAY MODULES	10-2
10.2.1 MODULE OPTIONS	10-2
10.2.2 DISTANCE LIMITATIONS	10-2
10.2.3 DISPLAY MODULE POWER BUSSING	10-3
10.2.4 CONFIGURATION	10-3
10.2.5 SMARTCONFIG CONFIGURATION	10-3
10.2.6 DIRECT LED CONTROL BY LOGIC	10-3
10.2.7 ZONE INDICATOR LABELLING	10-3
10.2.8 COMMON ALARM TYPE INDICATIONS	10-4
10.2.9 CHANGING THE ALARM SIGNALLING TYPE	10-5
10.3 ALPHANUMERIC ALARM DISPLAY	10-5
10.3.1 ZONE INFORMATION ON THE LCD	10-5
10.3.2 ALARM DISPLAY DESIGN	10-6
10.4 USING RZDU PORT	10-6
10.5 RDU/NSA	10-6
10.5.1 GENERAL	10-6
10.5.2 CONNECTION	10-7
10.5.3 CONFIGURATION	10-8
10.5.4 SHORT CIRCUIT ISOLATED TX OUTPUT	10-9
10.6 IO-NET MIMIC DISPLAYS	10-10
10.6.1 ORDERING DETAILS FOR IO-NET	10-10
10.6.2 IO-NET WIRING	10-10
10.6.3 CONFIGURATION	10-11
10.7 REMOTE FBP	10-12
10.8 NETWORKED REMOTE DISPLAYS	10-13
<u>11 ALARM ROUTING/BRIGADE SIGNALLING</u>	<u>11-1</u>
11.1 ALARM ROUTING/BRIGADE SIGNALLING OPTIONS	11-2
11.2 CENTAUR ASE	11-2
11.3 BRIGADE RELAYS	11-3
11.4 POWER SUPPLY FAIL OUTPUT	11-3
11.5 WEST AUSTRALIA ASE	11-3
11.6 SOUTH AUSTRALIA	11-4
11.7 NORTHERN TERRITORY	11-4
<u>12 REMOTE ACCESS</u>	<u>12-1</u>
12.1 REMOTE ACCESS	12-2
12.1.1 GENERAL	12-2
12.1.2 V-MODEM	12-2
12.1.3 V-MODEM ORDERING DETAILS	12-4
12.1.4 COMMERCIAL PSTN MODEM	12-4
12.1.5 PIB	12-5
12.1.6 TERMINAL ADAPTOR	12-5
12.1.7 PANELX	12-6
12.1.8 TELEPAGER INTERFACE	12-6
12.1.9 DIAG/PROG PORT AS PRINTER	12-7
<u>13 UPGRADING EXISTING SYSTEMS</u>	<u>13-1</u>
13.1 UPGRADING EXISTING <i>MX1</i> TO MULTI-LOOP	13-2
13.1.1 UPGRADING EXISTING <i>MX1</i> PANELS USING THE PA1011 CONTROLLER	13-2
13.1.2 UPGRADING EXISTING <i>MX1</i> PANELS USING THE PA1081 CONTROLLER	13-3
13.2 UPGRADING EXISTING <i>MX1</i> TO NETWORKING	13-3

13.2.1 EXISTING <i>MX1</i> PANELS USING THE PA1011 CONTROLLER	13-3
13.2.2 EXISTING <i>MX1</i> PANELS USING THE PA1081 CONTROLLER	13-4
13.3 UPGRADING <i>MX1</i> FAN CONTROLS	13-5
14 NETWORKING	14-1
<hr/>	
14.1 INTRODUCTION	14-2
14.2 I-HUB	14-3
14.3 PIB (PANEL-LINK IP BRIDGE)	14-5
14.4 DIRECT CONNECTION	14-9
14.5 PROGRAMMING	14-9
14.5.1 HARDWARE TABLE	14-9
14.5.2 SYSTEM TABLE	14-10
14.5.3 SID POINTS TABLE	14-11
15 APPENDICES	15-1
<hr/>	
15.1 APPENDIX A - ASSOCIATED DOCUMENTATION	15-2
15.1.1 OTHER <i>MX1-AU</i> MANUALS	15-2
15.1.2 OTHER DOCUMENTS	15-2
15.2 APPENDIX B – GLOSSARY OF TERMINOLOGY	15-3
15.3 APPENDIX C – GLOSSARY OF ABBREVIATIONS	15-4

Amendment Log

1.0	1 May 2009	Original Issue.
1.1	6 December 2011	Updated throughout for firmware V1.40 operation including multi loops operation.
1.5	21 November 2013	Updated for <i>MX1</i> Networking and firmware V1.50.
1.51	25 August 2014	Updated for firmware V1.51; new AAF operation, Printer port option, new section for South Australia operation including FBP point disable option, minor editorial fixes.
1.60	20 February 2015	Updated for firmware V1.60; new AS1668 Controls, DDM800 and Quad I/O modules, new AS4428.3:2010 Fire brigade panel, editorial fixes.
1.61	6 May 2015	Added FP1084 to Section 3.1.1 and 8.2. Added expansion cabinets to Section 8.2.1. Table 6.1 – revised note for LPS800 alarm current. Figure 8.16 – changed to show only 192 LED zones. Figure 8.19 and text corrected to show Supply Air Alarm instead of Compartment Alarm.
1.62	11 November 2015	Amended Figure 7.2 to use GPOUT1, §7.22 to better explain multiple T-GEN 50 wiring, §8.2.1 to put multiple cabinets together, and §8.17.5 to state 814PH/850PH on AAF zone is now supported. Added Section 11.7 NTFast and amended Section 3.10.
1.70	24 August 2017	Re-branded manual to Johnson Controls. Updated for firmware V1.70. <i>MX1</i> now supports SIO800, D51MX. <i>MX1</i> now supports ADF – Alarm Delay Facility Section 8.27 – silence buzzer deactivates strobe. Updated for AS 1670.1:2015.
1.71	1 December 2017	Support for T-Gen2, incl. Sections 7, 8 and 9.
1.72	24 October 2018	Support for T-Gen2 Grade 2, sections 7, 8, 10.
1.73	25 February 2019	FV421i information added. Obsolete TPI and V-Modem. Fig 7.2.
1.80	24 April 2020	P80SB, P80/1AVB, P80AVR/W, 80DSB added.
1.81	10 November 2020	Added QE20 connection information s7.12.FV421i to DDM. Updated for AS 1670.1:2018.
1.82	20 September 2022	Section 5.10.2 – added FV421i & 801FEx approved to AS 7240.10:2018

THIS PAGE INTENTIONALLY LEFT BLANK

1 Scope

1.1 Scope

This manual provides information for personnel responsible for planning, ordering, installing and configuring an *MX1* Fire Alarm System using the PA1081 Controller and V1.80 onwards firmware. It is assumed that such staff have been trained to plan/install fire alarm equipment and are familiar with the relevant standards.

The manual is divided into the following chapters:

- Chapter 2 gives a general overview of the system, with a description of some of the *MX1* concepts such as access levels, alarm delays, and zone and point status.
- Chapter 3 contains detailed specifications for *MX1*.
- Chapter 4 summarises the procedures for planning and designing a system, configuring the panel, and selecting appropriate alarm devices and other hardware.
- Chapter 5 lists and describes the wide variety of *MX* Loop devices. Installation and wiring are covered.
- Chapter 6 considers the design and wiring of the *MX* Loop itself. It also details the calculations to ensure the design is acceptable.
- Chapter 7 gives wiring and configuration for a variety of alarm devices, including T-Gen2 and QE20.
- Chapter 8 gives various options for configuring *MX1* for the requirements of specific installations including cabinet choices, use of GP inputs and outputs, AS 1668 controls, and AIF and AAM configuration.
- Chapter 9 covers the calculation of battery and power supply requirements.
- Chapter 10 covers the installation and configuration of zone display modules, and the use of various types of remote displays: Remote FBP, Remote Display Unit (RDU), and IO-NET Mimics.
- Chapter 11 covers the various brigade signalling options, including the Centaur ASE, Brigade Relays, and power fail output.
- Chapter 12 considers various methods of remote access including V-Modem, PSTN modem, direct serial connection and network connection via Ethernet.
- Chapter 13 describes the steps involved in upgrading existing *MX1* systems to V1.60 onwards to take advantage of new features such as multiple *MX* loops, Remote FBP, Networking, etc.
- Chapter 14 describes networking of *MX1* panels and connection to other compatible Panel-Link devices.

Appendices are provided for:

- Associated Product Documentation
- Glossary of Terminology
- Glossary of Abbreviations

The Vigilant *MX1* Wiring Diagrams Manual (LT0442), included with each *MX1* Panel, provides further wiring diagrams and gear plate mounting information.

2 System Overview

2.1 General Description

The VIGILANT *MX1* is a compact, self-contained, analogue addressable Fire Alarm System.

It is capable of controlling up to 250 *MX* addressable devices on its in-built *MX* loop, with up to 1A available to power devices on the loop. Up to 7 additional *MX* loops can be added by fitting *MX* Loop Cards.

Networking of *MX1* panels together allows diverse systems to be created, or for connections to other compatible Panel-Link devices to be achieved.

MX1 is programmed offline using SmartConfig PC software. Two configuration databases are held in the *MX1*, and in the event that one datafile is corrupted, the system will default to the other datafile.

2.1.1 Detectors and Devices

MX1 contains a built-in analogue addressable detection and control loop using the *MX* series of detectors, input and output modules. Additional loops can be added by fitting the *MX* Loop Card. Each loop supports up to 250 devices.

2.1.2 Displays

The primary display of the *MX1* is a 4 line by 40 character backlit LCD on which the status messages and prompts are shown. The *MX1* supports up to 999 zones.

Individual zone LED indicators can be added, in blocks of 16, up to a total of 192. The standard cabinets have space for 32 zones (no LED boards are fitted as standard). The *MX1* 16 zone LED display board has 16 red LEDs for alarm/operate and 16 yellow LEDs that are on steady for disable and flash for fault.

2.1.3 Outputs

MX1 has a range of relay outputs for controlling alarm devices and ancillary equipment. Many of these outputs can be configured for fault supervision from a range of supervision modes to suit the application. Addressable relay modules can be used to supplement these outputs or to reduce wiring costs between the *MX1* unit and the ancillary equipment.

MX1 has internal mounting options for several alternative tone/speech generators to drive 100V loudspeaker networks.

2.1.4 Power Supply

MX1 operates primarily from the standard mains supply, with a battery supply and integral PSU/charger to maintain operation in the event of mains power failure.

The standard 5A PSU has sufficient capacity to suit most installations.

See Chapter 9 for battery and PSU calculations.

2.1.5 Remote Displays

A Remote Fire Brigade Panel (RFBP) can be connected to the *MX1* to provide a second operator interface or a remote brigade attendance point unit. *MX1* includes an RZDU port which can be used to power and communicate with up to 8 supervised Remote Display Units. As well as these, other RZDU compatible equipment such as IO-NET and QE90 EWIS may also be connected to this port.

2.1.6 Logging Printer

A serial printer may be connected to the *MX1* to provide a log of events and operator actions. Refer to Chapter 8 (Application – Event Logging Printer) for selection and installation details.

2.1.7 Remote Access

Remote access to the *MX1* panel can be arranged by using a V-Modem, PSTN Modem, or Ethernet connection via a PIB or Ethernet-to-Serial adaptor. PanelX software is run on the PC and emulates the user interface (LCD and Keyboard) of the *MX1*. A Telepager Interface (TPI) (now obsolete) can also be connected to *MX1* to send event messages to alphanumeric pagers or text-capable cellphones.

2.1.8 Networking

With the addition of suitable network interface equipment the *MX1* may be combined with up to 250 other *MX1* panels into one large network to share alarm, display and control information. The network may include certain other Panel-Link compatible devices including AS4428 panels MX4428 and F3200.

2.1.9 Fire Fan Control Panels and Distributed Switch System

With the addition of fire fan control hardware the *MX1* can support up to 126 fire fans per panel. Fire fans can be duplicated across a Panel-link network, with multiple Fire Fan Control Panels (FFCP) able to view the status of, and control, the operation of fans on different *MX1* panels.

The fire fan controls are based on the Distributed Switch System (DSS). The DSS is able to provide general purpose switches and indication functions for plant isolation, drain valve activation, etc. The DSS controls are able to be duplicated over the Panel-link network.

2.2 System Structure

Figure 2.1 shows the structure of the standard *MX1*, and the functional interconnections between the hardware modules in the cabinet.

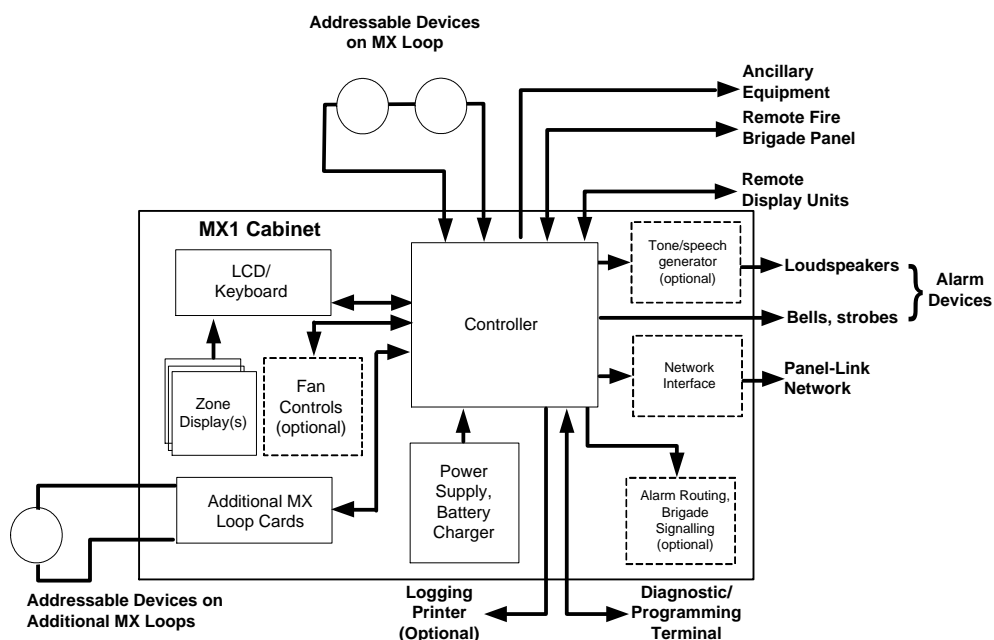

Figure 2.1 – Block Diagram of *MX1*

The Controller is the core part of the *MX1*. It:

- contains nearly all of the interfaces to external equipment
- monitors and distributes the power from the power supply
- receives keypresses and other front panel control operations from the LCD/Keyboard and passes back information to be presented on the LCD and zone displays
- powers and communicates with addressable devices on the in-built *MX Loop*
- interfaces to optional *MX Loop Cards* and Fan Control cards
- sends zone and text information to any connected Remote Display Units, and event messages to the optional logging printer
- sends alarm and fault signals to the alarm routing/brigade signalling equipment
- controls alarm devices of various types
- controls ancillary equipment
- generate and processes messages sent on the Panel-Link network.

The LCD/Keyboard manages the front panel operation. It detects keypresses on the keyboard and passes these to the Controller for processing. The Controller sends back text to be displayed on the LCD, and control information about which indicators and sounders on the LCD/Keyboard should be active. The Controller also sends a stream of information about which zone indicators should be lit or flashing, since the LCD/Keyboard drives this optional chain of zone display boards.

The LCD/Keyboard also detects the state of its switch inputs and sends this to the Controller for processing. The Controller, in turn, sends back control information for the open collector outputs.

2.3 Operator Access levels

The *MX1* operator interface uses the concept of Access Levels to manage access to front panel commands that display or affect the state of the system. These Access Levels are based on the descriptions found in AS 7240.2.

There are four Access Levels: 1, 2, 3 and 4.

The first 3 access levels are for operator access to the LCD and controls, while access level 4 covers access to the programming and configuration functions of *MX1*.

2.4 Internal Controls

Inside the *MX1* cabinet are these controls:

- Mains outlet switch – switches the mains supply to the power supply/battery charger
- RESET on the Controller – forces the system firmware to restart execution
- DATABASE WRITE ENABLE – this link on the Controller allows the stored system datafiles to be rewritten. Note that a new datafile can be loaded into the *MX1* without having to halt alarm processing.
- FIRMWARE WRITE ENABLE – this link on the Controller allows the system firmware to be updated. This should be fitted only when firmware updates are being done, otherwise alarm processing may halt unexpectedly.

2.5 Device Alarm Processing

A critical part of a fire alarm system is the early detection of a fire, and smoke and heat detectors are critical to this early detection.

If early detection were the only requirement, then this could be easily achieved by making the detectors as sensitive as possible. However, this would lead to numerous false activations or nuisance alarms due to traces of dust or wafts of warm air that had nothing to do with a fire. Given the disturbance and cost of a nuisance alarm, detector sensitivity alone is not sufficient.

MX1 supports a number of techniques to assess a detector's response and decide whether it represents a real fire. The detail of the verification method depends on the type of detector.

AVF is for conventional/collective detectors. Algorithms are provided for analogue addressable devices. These are discussed in the next sections.

2.5.1 Conventional Detectors - AVF

For conventional point type smoke detectors, the smoke sensitivity is set internally in the detector. The detector's only response is to signal that this level of smoke has been reached, and the detector latches in this state.

The AVF technique for this type of detector is to reset the detector to its normal state and start a timer running. The timer is typically set for about 2 minutes. If the detector activates again during this period, this is immediately taken to be proof of a real fire situation, and normal alarm processing is done, i.e., activate alarm devices and alarm routing. If the timer runs out and the detector has not re-activated, no further action is taken.

If the initial detector activation was caused by some stray event such as a waft of dusty air, it is unlikely to repeat during the timer period, and therefore will be ignored.

In *MX1*, AVF for conventional detectors applies only to the DDM800 and DIM800 *MX* modules. The details of the AVF delays are set in the delay profile assigned to the module, and can be viewed and adjusted with the configuration tool SmartConfig.

For the DDM800 the AVF delay, if enabled, is applied only when the circuit is in the alarm band, because it is probably a smoke detector, but not the fast alarm band, because it is probably an MCP or heat detector.

2.5.2 Analogue Addressable Detectors - Algorithms

These devices have a more subtle range of responses to fire products. Heat detectors report the actual temperature, smoke detectors report an actual smoke density, and CO detectors report an actual CO concentration. Some devices contain dual or multiple types of sensor.

The *MX1* processes the values from each detector according to the selected algorithm to determine the various conditions – alarm, pre-alarm, fault, etc.

For heat detectors, a common processing technique includes “rate-of-rise”, i.e., the rate at which the measured temperature increases, along with the actual temperature. Filtering and thresholds are applied to the sensor reading to decide whether a real fire situation has been detected.

For 850 series and intrinsically safe detectors using the count-of-3 algorithm a fixed temperature alarm is signalled after the temperature threshold is exceeded for 3 consecutive polls, and a ROR alarm is signalled after the ROR alarm threshold is exceeded for 6 polls.

814 series heat detectors utilise the processing shown in Figure 2.2.

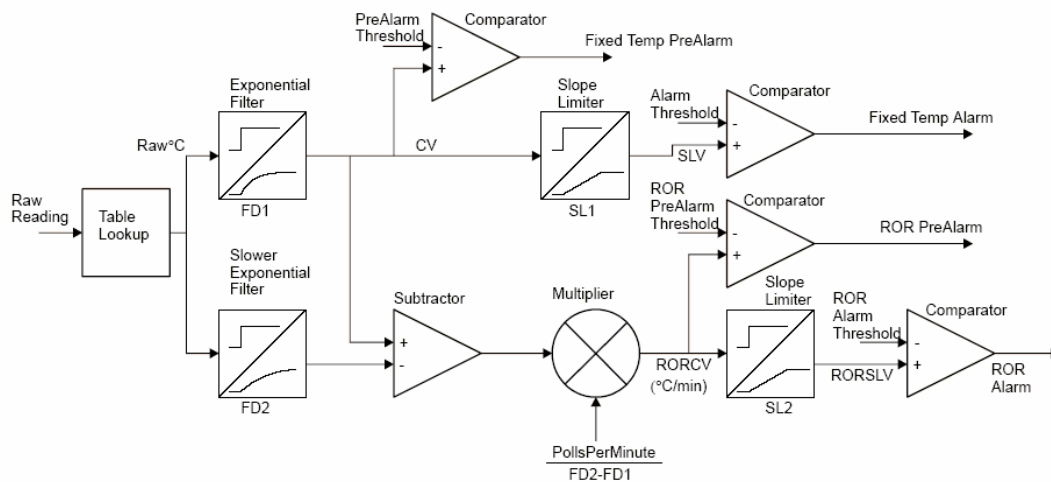

Figure 2.2 – 814 Series Detectors Heat Processing Diagram (Conceptual)

MX1 applies by default an algorithm called FastLogic (refer Figure 2.3) to photoelectric and combined photoelectric and heat detectors. This is a technique that uses “fuzzy logic” to process the analogue value and its changes over a short period of time into a predictor of there being a fire. It can produce a pre-alarm and an alarm condition.

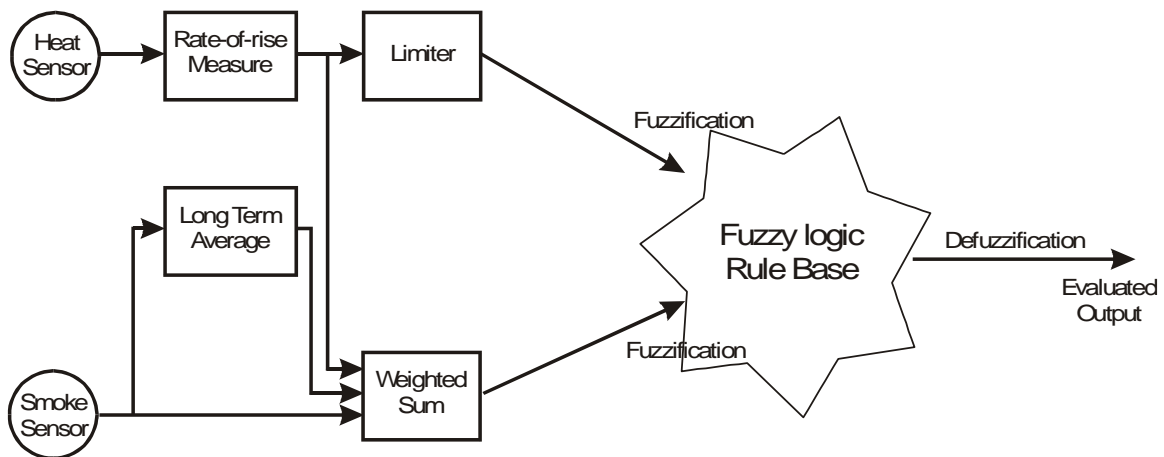

Figure 2.3 – FastLogic Process (Conceptual)

For 850 series and intrinsically safe photoelectric smoke detectors, MX1 can alternatively utilise a count-of-3 algorithm. For an alarm to be signalled the alarm threshold must be exceeded for 3 consecutive polls. This can also be applied to a combined photoelectric and heat detector – in which case heat enhancement can occur whereby a rising temperature increases the smoke reading to make the detector enter alarm faster.

For the count-of-3 algorithm, a sudden large increase in the sensor reading will cause the required verification count for an alarm to be increased to 10 consecutive polls. This is because a large increase in the smoke level is unlikely to have been caused by a fire, but rather be a false alarm.

For 814 series photoelectric smoke detectors, MX1 can alternatively utilise an algorithm called SmartSense. This can be applied to a photoelectric-only or a combined photoelectric

and heat detector. This uses a set of filters and thresholds as shown in Figure 2.4 to produce a final alarm and pre-alarm decision.

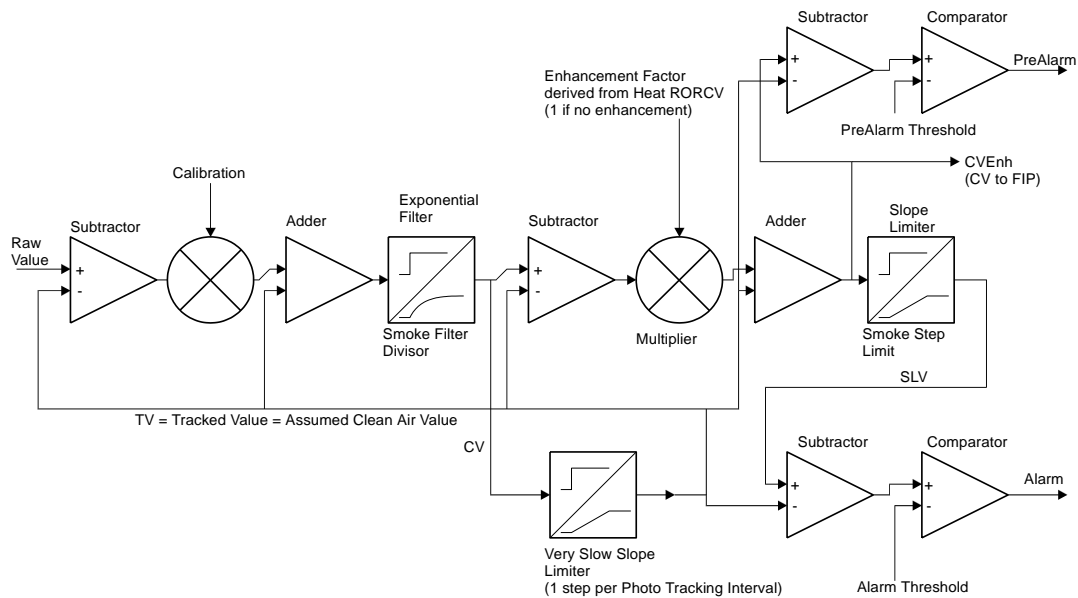

Figure 2.4 – 814 Series Detectors SmartSense Process (Conceptual)

MX1 uses similar techniques to these for ionisation smoke detectors and CO detectors, with appropriate filter settings and thresholds.

Triple sensor detectors such as 850PC operating in universal or resilient mode utilise count-of-3 style algorithms for all 3 sensors. Some additional filtering is applied to the detector readings. Cross enhancement between the sensors is used to improve the alarm sensing when multiple sensors detect fire phenomena. The photoelectric smoke reading is enhanced by rising temperature, and the alarm threshold is reduced by rising CO level.

These settings can be viewed and adjusted with the configuration tool SmartConfig. Refer to the SmartConfig manual or the help file.

2.6 Alarm Investigation Facility (AIF)

AIF is defined in AS 4428.10. AIF provides a preset delay between indication of the alarm at the *MX1*, and activation of alarm routing and the alarm devices. This allows the cause of an alarm to be investigated by suitably trained staff, and nuisance alarms identified and reset, without calling the brigade. If the alarm is not acknowledged or a manual call point is activated, the *MX1* will activate its alarm routing and alarm devices outputs.

The facility is intended for use in situations where an alarm might be triggered by normal features of the local environment – such as smoke or humidity – that may not constitute an emergency.

AIF can be applied to the whole system or to one or more individual zones as required.

Before implementing AIF, check that your planned AIF configuration conforms with local authority requirements. Installations configured for AIF must be sanctioned by the local fire authority.

AS 4428.10 contains more details for using AIF.

Programming *MX1* to use AIF is covered in Section 8.16.

2.7 Alarm Acknowledgement Facility (AAF)

AAF is defined in AS 1670.1 (Section 3.2.2). AAF provides a preset delay between annunciation of an alarm locally within a Single Occupancy Unit (SOU), and the annunciation of the alarm condition for that SOU on the fire alarm system. This allows the occupant of the SOU to acknowledge the local alarm indication and investigate (and if possible, clear) the cause of the alarm. If the local alarm indication is not acknowledged or the local alarm is not cleared within the preset times, then the *MX1* will annunciate the alarm and activate the alarm routing and alarm device outputs.

AAF is intended for use where a trained person can be made responsible for the SOU, for example an apartment in an apartment block.

The *MX1* AAF configuration requires a Vigilant Alarm Acknowledgement Module (AAM2) for each SOU.

Further details on configuring AAF are contained in Section 8.17.

2.8 Alarm Delay Facility (ADF)

ADF is defined in AS 1670.1 (Section 3.2.3). It is similar to AAF, in that it is designed to allow an apartment or SOU (Single Occupant Unit) resident to clear the smoke caused by a false alarm before the fire brigade is called. A smoke detector with a sounder base, but no acknowledgement module, is usually required. Details for configuring ADF in *MX1* are contained in Section 8.25.

2.9 Residential Installations

MX1 is suitable for use in residential situations such as nursing homes where there is potential for nuisance alarms. The *MX1* can be configured to respond to a smoke alarm with only a local alert and without registering the alarm at the fire panel unless a heat detector or other alarm occurs, or a callpoint is activated. The *MX1* can be configured to indicate or not indicate alarm for a smoke detector alarm on a residential zone.

Residential configuration is intended for use on a room-by-room or apartment-by-apartment basis, rather than system-wide.

An example of residential use is given in Section 7.6.

2.10 System Operation

Modern software-controlled fire alarm systems use microprocessors to provide the required system behaviour by means of stored instructions. These instructions contain the “rules” for how input signals from the physical hardware are interpreted and processed, and how these signals are combined to produce output signals to be passed back to the physical hardware.

There are two types of stored instructions:

- System software (firmware) – this comprises the core instructions used by the microprocessor to define and control the intended range of possible system behaviours, i.e., the allowed rules. System software is common to the make and model of the fire alarm system. It is loaded into the system during manufacture and can be field updated as new versions are released.
- Site-specific configuration data – this information is used by the system software to determine which of the allowed rules should be used and where they should be

applied. This information is specific to a particular installation of the fire alarm system. It is loaded into the system during installation, and is often changed and adjusted in the field, to match building extensions and other changes at the installed site.

An important part of *MX1*'s design is the unusually wide range of allowed rules defined by the system software. Furthermore, the *MX1* system software also allows many of these rules to be modified by the configuration data. Because of this, it is possible to change or extend the basic alarm processing rules to meet the requirements of particular standards and/or particular installations or types of installations.

This gives the *MX1* system a great deal of flexibility and adaptability. However, to prevent this flexibility from overwhelming a system designer, the configuration software tool, SmartConfig, provides simplified options and pre-packaged profiles (templates) to cover the most common requirements. This means that a system designer only has to deal directly with the full flexibility of *MX1* in the few installations that really require it.

The *MX1*'s flexibility has the potential for an inappropriate configuration to upset mandatory behaviour required by local standards and codes. To guard against this, the configuration tool protects some key parts of the configuration datafile from accidental changes.

A key part of achieving this high degree of flexibility has been to use the concept of "points" to represent most of the logical or physical parts of the system. Despite the fact that the actual system components being represented are physically and electrically diverse and complicated, the points that are used to represent them in the system software are relatively simple and consistent in behaviour.

2.11 SID

The SID address is a unique number in the range 1-254 allocated to each panel or device on a Panel-Link network. It allows equipment on that panel/device to be identified and controlled.

2.12 Points

In the *MX1*, a point is a representation of a part or component of a fire alarm system. Some examples are:

- a detector such as a heat sensor
- a relay output that could control alarm devices such as bells
- an internal part of the control equipment such as a fuse or power supply status.

A device is the collection of all sub-points associated with a physical device. A device number can be used (usually) to perform a command (such as enable, disable, reset) on all sub-points of the device without an operator needing to know how many sub-points it has.

2.12.1 Point States

For each point in the system, there is a state. This point state is a standardised condition derived from the actual status of the part of the system represented by the point. The point state can be one or more of:

- **Normal** – the component is operational and no other condition is present.
- **Pre-Alarm** – the component is a detector that has reached a condition suggesting an impending alarm.

- **Alarm** – the component is a detector and has activated. Generally, this calls the fire brigade.
- **Operate** – the component is an output device (relay, transistor etc.) and has activated.
- **ActInput** (Active Input) – the component is an input device that is being driven out of its normal condition, but is not in alarm or fault.
- **Fault** – the component is in a condition that may adversely affect its ability to function correctly.
- **Dirty** – a detector is in a state that requires maintenance/attention.
- **Disabled** – the component has been disabled by the operator to prevent it from affecting system operation.
- **Device Fail** – communication with this *MX* device is not possible (for example, because it has been removed from the loop).
- **Type Mismatch** – the wrong type of *MX* device is installed/programmed at this address.
- **TestOp** (Test Operate) – the component is under test and has been put into the operate state.
- **AutoReset** – the component is undergoing an auto reset test.
- **AlarmTest** – the component is undergoing an alarm test.
- **AITstFail** (Alarm Test Fail) – the component has undergone an alarm test and has previously failed. This state clears after a successful alarm test.

Not all of these states apply to all points, e.g., input points will never be in the Operated state, and output points will never be in the Active Input state.

2.12.2 Point Values

All points have a state, but some can also have analogue values, usually a whole number between 0 and 255. The meaning of the analogue value and the conversion factor to normal units depends very much on the particular type of point. For a smoke detector, one value might represent the smoke level. For a heat detector, one value might represent the current temperature. For an internal system point for battery status, one value might represent the battery voltage.

2.12.3 Point Numbering

In *MX1*, points are identified by a three part number with the form **Eq.Dev.Sub** where the parts are:

- Eq – Equipment number – the part of the *MX1* system this point is in.
- Dev – the physical device number within the particular equipment part, which will usually relate to a specific part of the system such as a detector or power supply.
- Sub – Sub-point number – which indicates which part of the particular device is required. Some devices do not have more than one sub-point, which means that their only valid sub-point number is 0.

For accessing a point on another *MX1* panel in a networked system, the SID of the other panel is multiplied by 1000 and added to the equipment number. For example, to access point 1.23.0 on an *MX1* panel with a SID of 12 you would use a point number of 12001.23.0.

In the *MX1* system, equipment numbers are:

- 1 – the *MX* Loop connected to the Controller
- 2 onwards – for the additional *MX* Loop devices when fitted
- 241 – the Controller in the *MX1* cabinet
- 242 – “pseudo points” created by the configuration to produce special operations
- 243 – the LCD/Keyboard in the *MX1* cabinet
- 244 – RDU points/equipment, if any RDU has been configured.

- 245 – status points for the additional *MX* loop cards and DSS modules when fitted.
- 246 – Remote Fire Brigade Panel points (if fitted).
- 247 – Network Status points.
- 248 – DSS Controls (Distributed Switch System, usually for Fire Fan Controls).

Refer to the *MX1-Au Operator Manual* (LT0439) for a detailed list and description of “internal” points for equipment numbers 241, 243, 244, 245, 246, and 247. Equipment 248 does not have points, but does have common status points under Equipment 245. For *MX* loop devices, sub-point 0 represents the physical device and is responsible for logging to the history and printer the Device Fail and Type Mismatch events. Note that when these events occur all sub-points will enter the fault state, but only sub-point 0 will log these events.

Disabling sub-point 0 will prevent the logging and the signalling of fault by sub-point 0, but will not prevent the fault being signalled on the other sub-points.

Therefore, when disabling an *MX* point that is in Device Fail or Type Mismatch it will be necessary to disable all sub-points of the device to remove the fault indication. When preparing a system database in SmartConfig it is recommended all sub-points of an *MX* detector have the same or similar text name.

For modules with multiple inputs such as MIO800, sub-point 0 should have a text name that represents the physical location of the module, whereas the text name of the individual inputs and outputs should reflect the function the input or output is used for.

2.13 Zones

In its most general sense, a zone is an area or region of the protected premises. The boundaries of zones usually have some significance in terms of the operation of the fire alarm system.

A zone can be a physical area, being part of the premises protected by the fire alarm system. In this instance, the boundaries of the zone coincide with physical boundaries such as walls, floors, or buildings. This is the meaning of the term “zone” used in most fire alarm standards, and is used by the brigade and other emergency personnel to manage evacuation and fire-fighting responses. These standards usually specify limitations on the extent of these zones which must be taken into account when planning a fire alarm system.

A zone can also be more abstract, such as all the heat detectors in a particular building.

Zones can physically overlap, if required (and permitted by the relevant standards).

For accessing a zone on another *MX1* panel in a networked system, the SID of the other panel is multiplied by 1000 and added to the zone number. For example, to access zone 37 on an *MX1* panel with a SID of 9 you would use the zone number 9037.

2.13.1 Mapping Points to Zones

Each *MX1* can support up to 999 zones, with each zone defined by “mapping” one or more points to it. The mapping effectively states that the point is “in” the zone, either by virtue of its physical location or its significance to the required operation.

This mapping establishes a particular relationship between the state of the point(s) in the zone and the resulting state of the zone, and the system behaviour resulting from that zone state. In most instances, the default behaviour of points and zones provided by the basic

mapping meets all the requirements for indication and signalling of alarms, faults and disabled conditions.

For the remaining few instances where the mapping behaviour does not meet the requirements, specific behaviour can be defined with User Logic equations in the configuration data file.

2.13.2 Zone States

Like points, the *MX1* maintains a state for each zone defined in the configuration. The zone State can be one or more of:

- **Normal** – this is the default zone state, when no other state is present.
- **Pre-alarm** – a point mapped to the zone has gone into the pre-alarm state.
- **FirstAlarm** – For an AIF, AAM or dual-hit zone a point has gone into alarm, but the zone is not in alarm due to a timer running or it is waiting for a second alarm.
- **Alarm** – a point mapped to the zone is in the Alarm state.
- **Resetting** – the zone is being reset.
- **Operate** – output points mapped to the zone will be operated.
- **Fault** – a point mapped to the zone is in the Fault state, or Device Fail or Type Mismatch.
- **Disabled** – the zone itself has been disabled or all points mapped to the zone are disabled.
- **TestOp** – all items mapped to zone will be put into test operate state.
- **AutoReset** – all items mapped to zone will be put into auto reset test.
- **AlarmTest** – the zone is undergoing an alarm test.
- **AITestFail** – there has been an alarm test run on the zone that failed. This state will clear after the next successful alarm test.
- **FltTest** – the zone is undergoing a fault test.

2.13.3 Zone Groups

MX1 also has a concept called Zone Groups, to which zones can be mapped. Each zone group combines the status of the zones that map to it, along with the alarm type (heat, smoke, MCP, etc.), and makes these states available for output logic equations to use. This can be used to drive LED indications showing a common alarm type, e.g. smoke alarm, for example.

2.14 System Processing

As described earlier, *MX1* uses points to represent most of its internal and external components. The configuration data controls the way these points interact to provide the required system operation.

Figure 2.5 shows diagrammatically the flow of information within the *MX1* system. The system software:

- interacts with the internal system and external hardware
- creates a table of points which includes point and sub-point status and analogue values, and
- generates logic tokens which summarise high-level system statuses.

The configuration data defines:

- what zones and *MX* Loop points are present and their operational parameters
- which points are mapped to which zones

- which zones are mapped to which zones/zone groups for default behaviours
- logic equations to provide special behaviour and interaction between points, zones and logic tokens, including behaviour to comply with required standards.

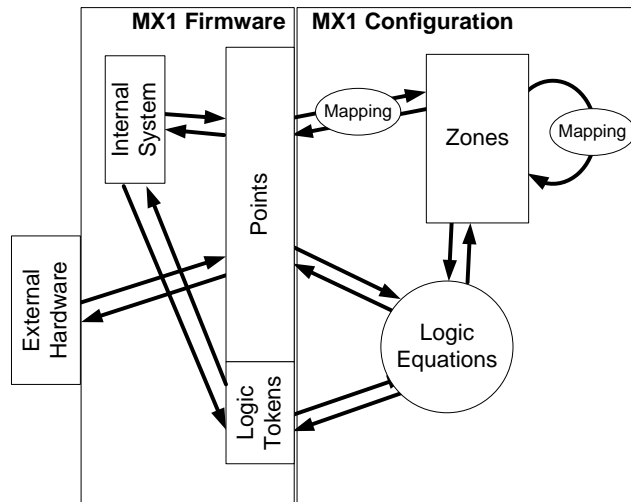

Figure 2.5 – Block Diagram of MX1's Internal Processing

The system configuration is created and maintained using the software tool SmartConfig.

SmartConfig provides a range of templates for creating new configuration data. Each template is designed to provide the basic operation for a particular type of installation, and includes profiles and behaviours that are required for that type of application. New templates can also be created by the user if required.

SmartConfig also performs some consistency checks on configuration data, and provides protection to profiles and user logic equations which control mandatory and other critical behaviour to prevent accidental changes to these.

Refer to the SmartConfig manual and on-line help for details on the available points and possible states, how these can be combined to provide the required alarm processing functions, and detail about templates and the general use of SmartConfig.

THIS PAGE INTENTIONALLY LEFT BLANK

3 System Specifications

3.1 General Specifications

3.1.1 Ordering Codes

FP0927 FP MX1 AUST 15U PANEL 3U CENTAUR ASE BRACKET
FP0928 FP MX1 AUST 15U PANEL 3U CUBE/WA ASE BRACKET
FP0948 FP MX1 AUST 15U PANEL 3U BLANK
FP1040 FP MX1 AUST 8U PANEL 3U BLANK
8U or 15U rack mounting cabinet with external door and either a Cube/WA ASE bracket, an ASE bracket or a blank panel. Includes Controller, keyboard/display, 5A charger, Operator Manual, Zone label blanks, EOL resistors for Controller inputs and ancillary supervision, loom for connection to T-Gen2 or T-GEN 50, Battery leads.

Optional Items:

FP0950 MX1 LOOP CARD KIT
FP0991 MX1 REMOTE FBP
FP1002 MX1, 16 ZONE LED DISPLAY EXTENDER
FP1027 FP, MX1, MX LOOP CARD/MX MODULE MTG BRKT, C/W MTG
FP1029 MX1 BATTERY BOX 8U X 180mm TITANIA
FP1030 EMPTY 15U CABINET (MCP WINDOW DOOR) TITANIA
FP1031 EMPTY 15U CABINET (BLANK DOOR) TITANIA
FP1056 FP, MX1 3U 12 X AS1668 DOOR, C/W 1st BD, LMs, LT & MTG
FP1057 FP, MX1 2 X AS1668 CNTRL BRD, C/W LOOM, LIT & MTG
FP1062 FP, 1982-197, MX1 4xDDM800 MTG BRKT
FP1063 FP, 1982-197, MX1 4xDDM800 MTG BRKT, C/W DDMS
FP1084 FP, MX1 15U EMPTY CAB, FULL WINDOW, TITANIA
FP1092 FP, 6U NTFASST BRIGADE I/F DOOR
FP1115 FP, T-GEN 60, 24V, C/W INSTALL LIT & MTG
FP1116 FP, T-GEN 120, 24V, C/W INSTALL LIT & MTG
FP1121 FP, GRADE 3 EWS UI 3U DOOR, C/W T-GEN 60 & MIC, GREY
FP1122 FP, GRADE 3 EWS UI DOOR, C/W LOOM & MIC, GREY
FP1143 FP, T-GEN2 HLI BOARD C/W LIT, LOOMS & MTG
LM0076 LOOM 1922-25 ECM PROG DB9 (FEM)-DB9 (FEM) NULL MODEM
ME0457 4U 80 ZONE LED DISPLAY DOOR

Refer to Section 3.10 and Chapter 14 for networking components.

3.1.2 Standards

The *MX1* is compliant with the following standards:

AS 7240.2-2004 Fire Detection and Alarm Systems – Control & Indicating Equipment
AS 7240.4-2004 Fire Detection and Alarm Systems – Power Supply Equipment
AS 4428.3-2010 Fire Detection, Warning, Control and Intercom Systems – Control and Indicating Equipment – Fire Brigade Panels
AS 4428.7-1999 Fire Detection, Warning, Control and Intercom Systems – Control and Indicating Equipment – Air-handling fire mode control panel.
AS 4428.10 Fire Detection, Warning, Control and Intercom Systems – Control and Indicating Equipment – Alarm Investigation
CISPR22 – Radio Disturbance Characteristics – Limits & Methods of Measurement. Class A.

3.1.3 Cabinets

Finish	Powdercoat DULUX Titania Ripple 288 1235Z
Style	8U and 15U Rack Cabinets
Dimensions	8U H440mm W550mm D210mm 15U H750mm W550mm D210mm
Construction	1.2mm and 1.6mm welded steel
Weight	8U 17kg packaged 15kg unpackaged 15U 24kg packaged 20kg unpackaged
Mounting Format	Suitable for surface or inset wall mounting. Includes outer door with clear acrylic window covering the keyboard and display.
Capacity	32 (8U) or 192 (15U) zone indicators out of 999 possible zones
Battery Space	8U Internal space for a pair of 12V batteries up to 17Ah 15U Internal space for a pair of 12V batteries up to 40Ah

3.2 Environmental Operation Conditions

Operating Temperature	-5°C to 45°C
Humidity	Up to 95% relative humidity at 40°C (non-condensing)

3.3 Electrical Supply Requirements

Mains Supply Requirements	Voltage	230Va.c. (192-253 a.c.)	
	Current	1.2A rms maximum	
	Frequency	50-60Hz	
	Termination	Switched mains outlet block mounted inside cabinet. Power supply connects via standard 3 pin mains plug.	
Battery Charger/ Power Supply	Charger Voltage	27.3Vd.c. (nominal at 20° C)	
	Temperature Compensation	-31mV per °C (nominal)	
	Non-Battery-backed Output Voltage	27.3Vd.c. (nominal 20°C)	
	Charger Voltage During Battery Test	21.5-22.0V (+VNBF)	
	Output Current	5.0A continuous rating, current limit at 5.5A nominal.	
	DC Operating Voltage	19.2-28.8V	
	Fused Outputs from Controller		Battery-backed: VBF1, VBF2, VBF3, VRZDU. Each fused at 3A, individually supervised.
			Non-battery-backed; VBNF, fused at 3A, supervised.
Fuse Types		All 5 x 20mm, glass cartridge type, 3A slow blow.	
Current Consumption	Controller	150mA nominal at 24V supply (system normal, LCD backlight off, no zone indicators lit, excludes MX Loop and other connected loads). 60mA per MX Loop Card	
	Zone Indicator	5mA nominal at 24V per active indicator.	
	Fan Module	8.5mA nominal at 24V per module.	

3.4 Inputs

Battery Input	<p>Two pairs of +ve and -ve screw terminals with capacity for 4.0mm² conductors.</p> <p>Battery cutout closes before 19.2V on rising voltage, and opens before 15V on falling voltage. LED status indicator shows connection status.</p>
General Purpose Inputs	<p>Two independent, protected inputs for connection to clean contacts or open collector outputs of ancillary devices. Normal, alarm conditions with optional open and short circuit supervision.</p> <p>Input characteristic is 1.2kΩ pull-up to 5V.</p> <p>Voltage bands are configurable. Default thresholds are 0.35V, 2.5V, 3.85V.</p> <p>These inputs share a common 0V terminal. All terminals have a capacity for 2.5mm² conductors.</p>
Door Switch and Integral MCP	<p>Two unprotected inputs are used to sense the state of the cabinet door switch and MCP (if fitted).</p> <p>If not required for an MCP, the MCP input can be used to sense another clean contact within the cabinet.</p>
Relay Supervision	<p>Each ancillary relay has an associated input for supervision. If not required for relay supervision, these can be used as supervised inputs for clean contacts.</p> <p>Input characteristic is 33kΩ pull up to +VBF (ANC1, ANC2) or 10kΩ pull-down to -5V (ANC3). Input thresholds depend on supervision mode (see 3.5 Outputs, below).</p> <p>ANC1 and ANC2 inputs can be driven by open collector outputs or contacts; ANC3 can only be driven by a clean contact.</p> <p>The operation of these inputs is set by the configuration.</p> <p>Each supervision terminal has a capacity for a 2.5mm² conductor.</p>
LCD/Keyboard Switch Inputs	<p>16 unprotected inputs suitable for unsupervised clean contacts.</p> <p>These inputs are available on a 26-way header suitable for connection to a protected input board (PA0479), unprotected termination board (PA0483), or AS 1668 4-way + common Fan Control Module (ME0472).</p>

3.5 Outputs

ANC1, ANC2	<p>Single pole, voltage free changeover contacts. Rated at 30Vd.c. 1A inductive, 2A resistive. Screw terminal, 2.5mm² conductor capacity. ANC1 connector is demountable, and can be replaced with a pre-made loom (LM0319) connection to a T-Gen2 or a T-GEN 50. Supervision modes: load mode 400Ω-15kΩ or one diode drop, door-holder mode (45-75% of VBF), contact mode (normal is closed to 0V), custom, or none, set by configuration.</p>
ANC3	<p>Single pole, voltage free changeover contacts. Rated at 30VDC, 5A resistive, 3A inductive. Screw terminals, 2.5mm² conductor capacity. Supervision modes: ANC3 (negative bias, up to three branches, 9kΩ ELD), contact mode (normal is closed to 0V, clean contact only), custom or none, set by configuration.</p>
General Purpose Outputs	<p>Two independent, protected, open collector outputs capable of driving loads up to 500mA from the 24V supply, plus common +VBF supply terminal. Supervision modes: load mode (240Ω-10kΩ load), or none, or as set by configuration. Operation mode: set by configuration. Screw terminals with 2.5mm² conductor capacity.</p>
Alarm Routing/ Brigade Signalling	<p>Relays - Alarm, Fault, Disabled, each with a single pole, voltage free changeover contact rated at 30VDC, 1A inductive, 2A resistive. The Fault relay is normally energised; Alarm and Disabled relays are normally not energised. Screw terminals with 2.5mm² conductor capacity.</p>
ASE Output	<p>Isolated, protected output suitable for direct connection to the FAS input of a Centaur ASE. Signals Alarm, Fault, and Disable. (Signals common with relays). Screw terminals 4.00mm² conductor capacity.</p>
SGD Interface	<p>Non-isolated unprotected output for direct connection to an adjacent SGD (none currently available for MX1-Au). 10 way FRC header.</p>
LCD/Keyboard Outputs	<p>16 unprotected open-collector outputs, suitable for driving LED indicators or relays from the MX1 24V supply. Individual loads must be less than 100mA. These are available on a 26-way header suitable for use with a protected output board (PA0480), unprotected termination board (PA0483), 24V relay board (PA0470), or AS 1668 Fan Control Module (ME0472).</p>
LCD/Keyboard Display Bus Output	<p>Suitable for driving up to 12 zone display boards - either small format FP1002 or large format FP0475, or a mixture.</p>

3.6 Communication Ports

MX Loop

MX1 can be operated only in Loop Mode.
Protocol: MX DIGITAL.

Controller

Feed Voltage 37-40V depending on load.
Current capacity 1.0A continuous, overload trips at 1.1A typical.
Four demountable screw terminals, AL+, AL-, AR+, AR- with 2.5mm² conductor capacity.
Supports up to 250 MX VIRTUAL analogue addressable detectors or modules.
Cable limit: 2,000m of typical TPS.

MX Loop Card

Feed Voltage 37-40V depending on load.
Current capacity 1.0A continuous, overload trips at 1.1A typical.
Four demountable screw terminals, AL+, AL-, AR+, AR- with 2.5mm² conductor capacity.
Supports up to 250 MX VIRTUAL analogue addressable detectors or modules.
Cable limit: 2,000m of typical TPS.

Serial Communications

Diag/Prog Port

DB9 male connector configured as RS232 level DTE.
Diag/Prog is used for loading configuration data and using diagnostic functions. This can be connected to a modem for remote access to the MX1. Data rate is set at 19200 bps. Can be programmed as printer output.

Serial Port 1

DB9 male connector configured as RS232 level DTE. Can be used for a logging printer. The data rate is set by configuration.

Other Serial Ports

Five 10-way headers configured as logic level (0-5V) DTE. Display Port is dedicated to the LCD/Keyboard connection. Data rate is fixed at 19200 bps, 8 bits, no parity. Serial Port 0 by default is assigned to RZDU, but can be re-assigned to other functions. Serial ports 2, 3, 4 and 0 are configurable for MX Loop Cards, Remote FBP, Network Interface, or AS1668 controls.

RZDU Port

Four 2.5mm² terminals providing +VRZDU, TX, RX and 0V signals to Remote Display Units (up to eight) or other RZDU compatible devices.

Protocol: Vigilant RZDU LCD-A

Data rate:1200bps

Cable Limits: 150Ω to furthest device, 100nF total line capacitance, including all wiring branches. Typically, these limits are met by 1km of TPS.

Network

The serial port programmed for networking can connect to a PIB or I-HUB network interface or to a single Panel-Link device using point-to-point communication.

3.7 External Controls

- External Keypad** Polyester keypad type, 29 keys.
- Fire Brigade Panel** NEXT, SILENCE BUZZER, SILENCE ALARM DEVICES, RESET, DISABLE keys.
Four soft keys beside LCD, 0-9 numeric keys, MENU, ZONE, OK, CANCEL.
FAULTS, DISABLES, TESTS, AIF.

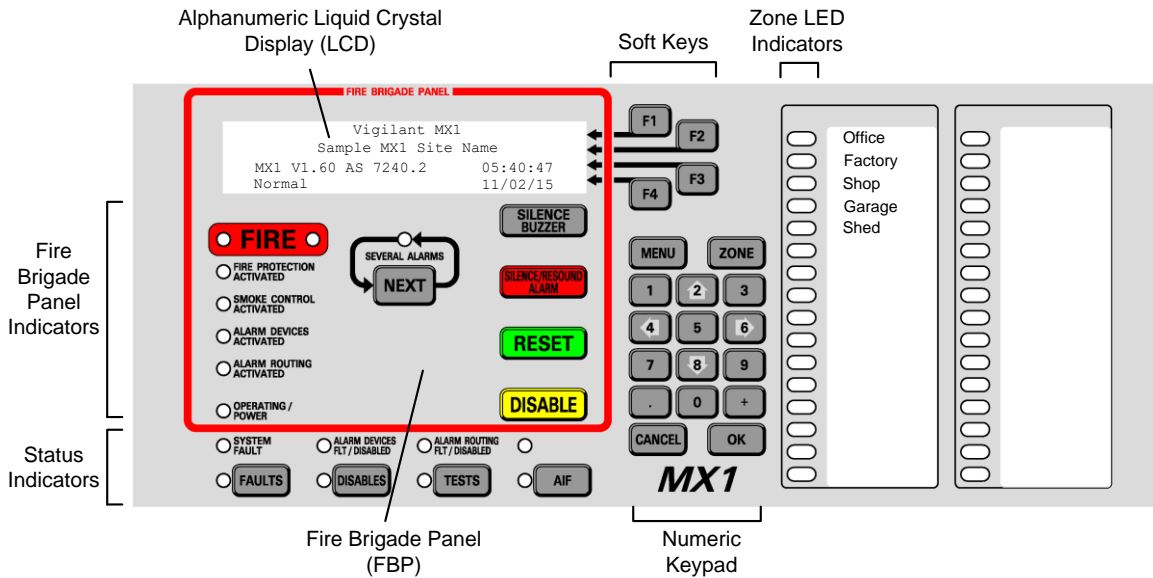

Figure 3.1 – MX1 Keypad

- Cabinet Lock** Keyed 003, to secure cabinet. Also operates internal switch to enable keypad functions.

3.8 Internal Controls

- Mains On/Off** Switches the AC mains supply to the MX1 power supply/battery charger
- Reset** “Reset” on Controller restarts the system immediately.
“Reset” on LCD/Keyboard restarts the LCD/Keyboard.
- Write-enable Links** Enable changes to the system configuration (DATABASE) or updates to the system firmware (FIRMWARE).
- Battery Connection Link** Force the battery cutout to reset and connect the battery to the charger.
- LCD Contrast** A control on the LCD/Keyboard to adjust the contrast of the LCD.

3.9 Displays

LCD	4 lines of 40 characters. Font height is 4.8mm, black text on a green/yellow backlight. Backlight operates while the keypad is in use or when an alarm occurs.
Status Indicators	<p>FIRE – lit steady red when an Alarm is present.</p> <p>FIRE PROTECTION ACTIVATED – lit steady red when gaseous fire-extinguishing system or other fire protection systems have been activated.</p> <p>SMOKE CONTROL ACTIVATED – lit steady red when ventilation/fan controls such as AS 1668 fan control system have been activated.</p> <p>ALARM DEVICES ACTIVATED - lit steady red when the alarm devices are activated.</p> <p>ALARM ROUTING ACTIVATED - lit steady red when an alarm signal is being sent to the monitoring system/fire brigade.</p> <p>OPERATING/POWER – lit steady green if mains power is applied to the <i>MX1</i>, flashes if mains not present and running on batteries. Off if no power applied.</p> <p>SEVERAL ALARMS – lit steady red when more alarms are present than can be simultaneously displayed on the LCD.</p> <p>SYSTEM FAULT – lit steady yellow if a system fault condition exists.</p> <p>ALARM DEVICES FLT/DISABLED – flashes yellow if there is a fault with the alarm devices; steady yellow if the alarm devices are disabled.</p> <p>ALARM ROUTING FLT/DISABLED – flashes yellow if there is a fault with the alarm routing; steady yellow if the alarm routing is disabled.</p> <p>FAULTS – steady yellow when there are faults present.</p> <p>DISABLES – steady yellow when disables are present.</p> <p>TESTS – steady yellow when any tests are in progress.</p> <p>AIF – steady yellow when the panel is in attended mode.</p> <p>SPARE – controllable by output logic.</p>
Zone Indicators	Up to 12 sets of 16 zone LED indicators. For each zone, a steady red LED shows Alarm status, a flashing yellow LED shows Fault, and a steady yellow LED shows Disable.
Internal Buzzer	Gives a short “beep” for a valid keypress of the keypad, a long beep for an invalid keypress.
DSS/Fan Controls	126 controls, each with 3 pushbuttons with indicators and 4 status indicators.

3.10 Other Optional Modules

The following are some optional modules that may be mounted in the *MX1* cabinet.

Note: The 8U cabinet does not have space/mounting facilities for some items.

Product	Part No.	Description/Usage
3U 60W GR3	FP1121	Grade 3 EWS 3U Door with T-Gen 60 and Microphone
3U Grade 3 UI	FP1122	Grade 3 EWS 3U door with Microphone
HLI board	FP1143	T-Gen2 HLI board with looms
Mini-Gen Mk2	PA1026	Multi Tone and Speech Generator (24V)
Strobe Driver	PA1043	ISO8201-compliant strobe driver module
16 Relay Outputs	PA0470	16-way relay output board
16 Input Module	PA0479	16-way protected input board
16 Output Term Board	PA0480	16-way protected output board
16 Output Unprotected Bd	PA0483	16-way unprotected output board
Dual Pole Relay Board	PA0730	Dual pole relay (24V)
Fuse Board	002-109K	4-Way Fuse Board
Centaur II ASE	FP0971	2 nd generation ASE for NSW/VIC/ACT
Centaur II Cube ASE	FP0974	ASE for QLD
Code Red ASE	-	W.A. Monitoring Interface
ASE Door	KT0199	3U 19" door to mount one Centaur ASE or V-Modem
Dual V-Modem Door	KT0212	3U 19" door to mount two V-Modems
Cube ASE Bracket	FZ9028	3U 19" door to mount Cube ASE or AIU
NFAST 6U Door	FP1092	6U door to mount Miri unit and PCB
T-Gen 60	FP1115	60 Watt Alert & Evacuate Tone Generator
T-Gen 120	FP1116	120 Watt Alert & Evacuate Tone Generator
100V Switching Module	FP1117	100V Audio Link Switching & Monitoring Module
100V Splitter Module	FP1118	100V Audio Line Splitter & Monitoring Module

Networking Equipment and Mounting Kits:

Part Number	Title & Description
FP0771	I-HUB RS485 Ring Network Adapter
FP0986	PIB IP Network Adapter
FP1012	Bracket to mount Moxa Fibre switch and 2 Ethernet Extenders
FP1013	MX4428/F3200 IP Networking Bracket
FP1044	IP Network STP Cable Termination Bracket
FP1032	Mounting bracket and looms to mount 2 OSD fibre-optic modems
OSD139HS	Fibre-Optic Modem for use with I-HUB, Multi-Mode (not AS 7240.2 listed)
OSD139HSL	Fibre-Optic Modem for use with I-HUB, Single-Mode (not AS 7240.2 listed)
SU0319	Moxa switch, 3 Ethernet Ports, 2 Multi-Mode fibre
SU0320	Moxa switch, 3 Ethernet Ports, 2 Single-Mode fibre
SU0325	Moxa switch, 5 Ethernet Ports (not listed to AS 7240.2)
SU0326	Moxa switch, 8 Ethernet Ports (not listed to AS 7240.2)
SU0328	Westermo Ethernet Extender, DDW-120

4 System Design Procedure

4.1 General

This chapter summarises the typical procedure of designing, dimensioning and configuring an *MX1* system. Detailed descriptions of the individual steps are given in the following chapters.

A fire alarm system must be reliable in all aspects and must be engineered correctly to suit the requirements of each installation. Consideration must be given to the following:

- Choice of basic system operation, for example whether the system is connected to the brigade or not.
- Choice of the most appropriate type of detectors and alarm devices.
- Choice of best position for detectors, alarm devices and Controller.
- Division of property being protected into zones.
- Consideration of level of protection (and hence cost) versus reduction in risk.

In all cases the importance of good planning cannot be over-emphasised. It is essential that the personnel responsible for planning and engineering fire alarm systems are properly trained, familiar with all the relevant fire alarm standards, and also with general fire alarm planning methods and procedures.

4.2 *MX1* System Operation

4.2.1 Components affecting basic system operation

The basic system operation of *MX1* is controlled by:

- System settings
- Point flags and Logging settings for selected controller points
- System Logic equations

System settings determine how the user interface functions, how power supply monitoring is done, how the system clock operates and so on.

The configuration of controller points, for example brigade relay outputs, determines whether brigade interfaces (alarm routing equipment) are monitored for faults, and whether activity on the brigade signals is logged.

System logic equations tie together the various system statuses to drive brigade relays (or not), determine which inputs are used for system functions, and control access to the keyboard according to access level and operational requirements.

4.2.2 System Profile-controlled *MX1* Operation

System Profiles (in conjunction with system logic) control the basic system operation.

Selection of a particular System Profile will automatically determine basic system settings, and the settings for the controller points. It will also determine how the corresponding System Logic will operate by providing “on/off” controls to the logic equations by use of special logic substitutions.

Selection of the inputs and outputs to drive and be controlled by System Profiles is still done manually.

4.2.3 Individual Settings for *MX1* Operation

All settings controlling operation appear individually in the System page, and the *MX1* Controller page. System Logic is fixed.

Changes to system operation must be done by changing settings individually.

4.3 Detectors

The steps in determining detector types and numbers are:

- 1) Using the site or building plans, divide the protected area into zones. This may already have been done by a consultant. The size and boundaries of these zones will be affected by the restrictions in the applicable fire alarm standards as well as the physical layout of the protected area.
- 2) In each room or section of the protected area, choose the type and number of detectors which are appropriate to the activities or hazards present and are compliant with the relevant fire alarm standards.
- 3) In each zone, allocate the required number of call points according to local codes or site requirements.
- 4) Where there are contact outputs from other systems that must be monitored, e.g., sprinklers or air handling units, allow for an addressable input module of an appropriate type, i.e., single or multiple input. There are several input options which can be used, depending on circumstances.
- 5) Where there are inputs to other systems that are driven by the fire alarm system, allow for addressable output modules of an appropriate type, e.g., a relay module or relay base.
- 6) Allocate a unique number to each device on each *MX* loop.

See Chapter 5 for more about addressable detectors and devices.

4.4 Intrinsically Safe Detectors

When devices are to be installed in a hazardous environment – that is, where flammable gases or vapours, combustible dusts or other easily ignited airborne substances may be present – Intrinsically Safe (IS) devices must be used. These devices are designed to operate at a power level too low to present a risk of ignition.

MX devices designated with the suffix “Ex” in the part number are Intrinsically Safe and suitable for use in hazardous areas if they are correctly selected and installed. In addition there are other Intrinsically Safe devices (such as S271i+) that do not carry this suffix.

Note that there are requirements for wiring in hazardous areas that must be satisfied. These include (but are not limited to):

- Matching “Ex” rating of equipment chosen with hazardous area classification.
- Ensuring cable capacitance and inductance are within the limits of the repeaters used.

- Providing adequate physical protection for equipment according to local hazardous area wiring regulations.
- Using cable of the correct insulation and physical strength according to local hazardous area wiring regulations.
- Complying with manufacturer's instructions for mounting of "Ex" rated devices.
- Ensuring that wiring for intrinsically safe equipment is sufficiently separated from non-IS wiring to ensure that stray energy cannot be transmitted into the IS part of the system.
- Intrinsically Safe devices **MUST** be installed in conjunction with suitable isolators. Within a hazardous area, both the Intrinsically Safe devices **AND** the wiring that connects them to the system **MUST** be isolated.
- Inspection and certification of the finished installation is generally required.

See Sections 5.10 and 6.6 for more details.

4.5 Alarm Devices

An appropriate type of alarm device or devices must be chosen to warn the occupants of the installation that a fire alarm is present. *MX1* supports a variety of alarm devices from simple tone generators to full building evacuation systems.

See Chapter 7 for more about alarm devices.

4.6 Ancillary Loads and Other Devices

Apart from the alarm devices, there may be additional external loads powered from the *MX1*'s internal supply. These loads must be identified and incorporated into the battery requirements calculations.

Interfacing may also be required between the *MX1* and other devices, e.g., printer, modem, remote buzzer.

See Chapters 8 and 9 for more details.

4.7 Zone Displays – Alphanumeric and Individual

Zones in alarm are displayed on the *MX1*'s alphanumeric LCD in a list of up to 99 alarms. Some aspects of alarm list operation are configurable.

However, there is often a need to have individual indicators for zones as well. *MX1* can be fitted with zone indicators in multiples of 16, comprising a red alarm indicator and a yellow fault/disabled indicator for each zone. As standard the 15U and 8U cabinet can accommodate up to 32 zone indicators in 2 modules of 16. Subject to sufficient rack space, an *MX1* can be expanded up to 192 zone LED indicators in 12 modules of 16.

See Chapter 10 for more about zone displays.

4.8 Remote Zone Displays

MX1 has several options for driving zone displays which can be at other locations of the protected premises. These remote displays can be compact alphanumeric displays, or individual zone indicators, or a combination. Some of these remote displays can also provide some remote control of the *MX1* system.

Additionally a Remote FBP can be connected to the *MX1*. This has the same LCD and keyboard as the *MX1* to provide a remote operator interface for the fire brigade or site personnel.

See Chapter 10 for more about remote zone displays.

4.9 Alarm Routing/Brigade Signalling

MX1 has been designed to interface to a variety of Brigade interfaces. In brief, the configurations supported are:

- ASE – an isolated protected 2 wire interface that connects directly to the FAS input of a Centaur ASE.
- Alarm, Fault and Disable voltage-free relay outputs are also provided directly on the *MX1* Controller. These allow connection to virtually any remote monitoring system.
- SGD-compatible 10 way FRC connector. Currently there is no suitable SGD for use in Australia.

See Chapter 11 for more about alarm routing/brigade signalling options.

Note that some systems are not required to be connected to the fire brigade. In these situations the brigade relay outputs may be assigned to other functions.

4.10 MX Loop Card

As supplied, the *MX1* provides a single *MX* loop for connecting to up to 250 devices. Where additional loops are required, these can be accommodated by installing *MX* Loop Cards. The system design needs to encompass the loop design and power requirements of these.

Installation procedures are covered in the *MX* Loop Card Installation Instructions (LT0443).

4.11 Battery Requirements

Once the full tally of required equipment for the *MX1* system has been determined, the necessary battery capacity for the system can be calculated. The size of the required battery may affect the size and type of cabinet required to house the system.

A calculation tool, *MX1COST*, is available to make this calculation a straightforward task, and to provide printed reports for inclusion in the system commissioning documents. This tool also checks that the load of each *MX* Loop is within acceptable limits. Alternatively, the calculation can be done manually for simple systems.

See Chapter 9 for more about PSU and battery capacity design.

4.12 User Logic for Custom Control

MX1 has a facility for setting up customised control logic to provide specialised functions that may be required in some installations, such as air handling and building services controls.

Special features that *MX1* includes to make preparation of output logic easier are:

- Logic substitutions – a textual name can be given to commonly used points, statuses, or even complete logic.
- Pseudo Points – there are 255 pseudo points whose status can be controlled via logic equations and the points map to zones/outputs, etc. These could be used to generate alarm/fault, etc., on complex situations.
- Templates – databases can be prepared with various pre-programmed settings and then saved to act as templates for new jobs.
- Logic blocks – these “wizards” allow pre-defined functionality (e.g., AS 1668 controls) to be inserted for specific inputs/outputs, etc.

Examples of user logic equations are given in this manual. Further information is contained in the SmartConfig User Manual.

4.13 Profiles

Profiles are used to store basic information and choices regarding the operation of *MX1*. Normally they do not need to be edited by the user. However profiles can be edited when necessary, or new profiles added to match site, state or country requirements.

All profiles are identified by name within SmartConfig. It is strongly recommended that names chosen for profiles should be descriptive of the specific function of the profile. Note that some profiles are already set up to comply with standards or other legal requirements. These are normally locked.

Refer to the SmartConfig User Manual for further information about profiles.

4.14 Networking

Some information on designing *MX1* networks is contained in Section 14 of this manual. Further technical details are contained in the *MX1* Network Design Manual LT0564.

4.15 Fire Fan Control Panels and Distributed Switch System

MX1 can provide a Fire Fan Control Panel (FFCP) of up to 126 controls per panel. There are 12 controls per 3U door fitted to a rack cabinet. Programming of an FFCP is done using Logic Blocks to simplify configuration.

As the FFCP application is based on the Distributed Switch System (DSS) the FFCP can be duplicated over a Panel-link network, allowing for multiple control locations able to view and control the fans at the same time. The DSS can be configured for general purpose switching and indication applications, such as control of test valves or plant isolation.

Section 8.18 describes how to design an FFCP for *MX1* and Section 8.23 describes how to configure the DSS for general purpose applications.

5 ***MX Devices***

5.1 Device Types

MX Devices fall into four basic types:

- Detectors
- Modules
 - Input (Monitor)
 - Output (Control)
 - Isolator (SCI)
 - Visual Alarm Devices (VAD)
- Bases
 - Universal Base
 - Short Circuit Isolator Base (IB)
 - Relay Base
 - Sounder Base
 - Sounder/Beacon (VAD)
- Intrinsically Safe Devices – refer to Section 5.10.

In addition, compatible non-addressable (conventional/collective) smoke, CO, heat or flame detectors may be connected to the MX Loop by means of the DDM800 Universal Detector Module or DIM800 Detector Input Module.

For details on each device refer to the respective installation instructions/manuals for the device.

MX addressable (including Ex rated) devices compatible with MX1 are as follows:

Table 5.1 – MX Device Types

Device	Description	Input / Output	Remote LED	Comments
814P	Photoelectric Smoke Detector	I/O	Y	Requires base
814PH	Photoelectric Smoke + Heat Detector	I/O	Y	Requires base
814CH	Carbon Monoxide + Heat Detector	I/O	Y	Requires base
814I	Ionisation Smoke Detector	I/O	Y	Requires base
814H	Heat Detector	I/O	Y	Requires base
801F	IR Flame Detector	I/O	N	Requires base
850H	Heat Detector with SCI	I/O	Y	Requires base
850P	Photoelectric Smoke Detector with SCI	I/O	Y	Requires base
850PH	Photoelectric Smoke and Heat Detector with SCI	I/O	Y	Requires base
850PC	Photoelectric Smoke, Heat and CO Detector with SCI	I/O	Y	Requires base
S271f+	Flameproof Triple IR Flame Detector	I/O	N	Flameproof
FV411f	Flameproof Triple IR Flame Detector	I/O	N	Flameproof
FV412f	Flameproof Triple IR Flame Detector	I/O	N	Flameproof
FV413f	Flameproof Triple IR Flame Detector	I/O	N	Flameproof
CP820/ CP830/ MCP820/ MCP830	Manual Call Point Manual Call Point with SCI	Input	N	Built-in LED
CIM800	Contact Input Module	Input	N	ELD 200Ω Alarm R (if used) 100Ω Max Wiring R 10Ω

DDM800	Universal Detector Module	Input	N	ELD 4k7 Ω Loop powered/ external supply
DIM800	Detector Input Module	Input	N	ELD 4k7 Ω Requires external supply.
LPS800	Loop-Powered Sounder Driver	Output	N	Controls & supervises loop- powered load up to 75mA.
MIM800	Mini Input Module	Input	Y	ELD 200 Ω Alarm R (if used) 100 Ω Max Wiring R 10 Ω
MIM801	Mini Input Module normally closed interrupt	Input	Y	N/O mode - ELD 200 Ω Max wiring R 50 Ω
MIO800	Multiple Input/Output Module	Input/ Output	N	3 Multi-State inputs 2 Relay outputs
P80AVB	Sounder/Beacon VAD Base	Output	N	
P81AVB	Sounder/Beacon VAD High Intensity	Output	N	
P80SB	Sounder Base	Output	N	
P80AVR	Wall-Mount Sounder/Beacon VAD Red	Output	N	
P80AVW	Wall-Mount Sounder/Beacon VAD White	Output	N	
QIO850	4 Input, 4 Output Module	Input/ Output	N	4 x Alarm/Flt Inputs 3k3 EOL 4 x Relay/ Switched Outputs
QMO850	4 Supervised Output Module	Output	N	4 x Supervised Switched Outputs
QRM850	4 Output Module	Output	N	4 x Relay/ Switched Outputs
RIM800	Relay Interface Module (unsupervised load wiring)	Output	N	2A 30VDC
SAB801	Loop-Powered Sounder base address module with Beacon Driver	Output	N	Controls Relay/ Sounder base. Includes red flashing beacon.
SAM800	Sounder base Address Module Driver	Output	N	Controls Relay/ Sounder base. No beacon.
SNM800	Sounder Notification Module (relay output with supervised load wiring)	Output	N	2A 30VDC Requires external supply
SIO800	Single Input/Output Module	Input/ Output	N	1 x Alarm/Flt Input 3k3 EOL 1 x Relay/ Switched Output
VIO800	MIO800 configured for connecting to VESDA units.	Input/ Output	N	3 Multi-State inputs 2 Relay outputs
VLC800	VESDA Aspirating smoke detector	I/O	Y	
Ex Devices				
801FEx	IS IR Flame Detector	I/O	N	Requires IS base

S271i+	IS Triple IR Flame Detector	I/O	N	
801CHEx	IS CO + Heat Detector	Input	N	Requires IS base
801PHEx	IS Photoelectric Smoke + Heat	Input	N	Requires IS base
801HEx	IS Heat Detector	Input	N	Requires IS base
IF800Ex	IS Contact Input Module	Input	N	
CP840Ex	IS Manual Call Point	Input	N	
FV421i	IS Triple IR Flame Detector	I/O	N	

The devices above are addressed by the 801AP Service Tool, 850EMT Engineering Management Tool, MX Loop Tester, or by command from the diagnostic menu of an MX1.

Non-addressable MX loop devices include the following:

- LIM800 Loop Isolator Module Short Circuit Isolator
- EXI800 IS Spur Interface Module (contains internal short circuit isolator)

The following bases may also be used:

4B	Standard Base (4")
4B-C	Continuity Base for 850 detectors (4")
4B-I	Isolator Base (4")
5B	Universal Base (5")
5BEx	Ex-rated Base (5") for Ex Detectors
5BI	Isolator Base (5")
814IB	Isolator Base (obsolete)
814RB	Relay Base
814SB	Sounder Base (obsolete)
802SB	Sounder Base (loop powered)
901SB	Sounder Base (external power)
80DSB	Sounder Base (loop powered)
D51MX	Duct Sampling Unit with a 4B-C base (requires 850P)

The 814RB Relay base may be plugged into a Universal Base or Isolator Base, or mounted directly on a wall/ceiling.

Note that none of these bases are addressable devices. The functional bases (relay, sounder) are controlled from the MX1 via the detectors or SAB801/SAM800 that are plugged into them.

The devices marked as "I/O" in Table 5.1 are always inputs, but may also be used as outputs via the Remote Indicator output and the signal to the functional base. The output functionality is programmable and is not necessarily related to the input status. Intrinsically safe "Ex" devices may not be used in relay or sounder bases.

The devices which have a remote LED output may drive a Vigilant E500Mk2 remote LED. The functionality of this LED is programmable and it does not have to follow the internal indicator status. See Figure 5.1 and Section 5.6 for wiring details.

MX1 can communicate with a mix of up to 250 addressable devices, within limits defined by loop resistance and capacitance, AC loading and poll times. Sections 6.4 and 6.5 provide a manual calculation method, however MX1COST can be used to verify a loop design against these limits.

The functional base output sub-point for MX addressable detectors can be used when the detector is fitted to one of the following bases.

- 814RB Relay Base
- 802SB Sounder Base
- 812SB Sounder Base
- 901SB Sounder Base
- 80DSB Sounder Base

Do not enable the functional base output sub-point if the detector is installed in any other base type. This is especially important for 850 series detectors in 4B-C continuity bases because if the functional base output is activated, it could open circuit the loop. This is because the functional base control signal is shared with a signal to activate the short circuit isolator in these detectors.

5.1.1 850 Series Detectors

The 850 series detectors have in-built short circuit isolators (SCI). To use the in-built SCI, the 850 detectors must be installed in a 4B-C base and wired correctly.

When fitted in the 4B-C base, the functional base output sub-point must be configured as unused (as the functional base output control will turn the SCI on/off).

850 series detectors can be fitted to the 4B, 4B-I, 5B, 5BI, sounder base and relay base: the internal isolator will simply become non-functional.

When 850 Series detectors are fitted to functional bases (80DSB, 802SB, 812SB, 901SB, 814RB) the yellow LED of the detector is turned on when the functional base is activated. This draws an extra 3mA of current. If a large number of 850 detectors turned on their functional bases at the same time, this could add extra current to the loop that is not allowed for. MX1Cost V2.13 onwards includes the facility to enter these devices separately so the current can be included in the MX loop calculations.

5.2 Device Installation – Mounting the Devices

5.2.1 Detectors and Detector Bases

Detectors plug in to a circular, plastic base which has holes for screw mounting to a flat surface, and screw terminals for connecting the loop wiring. The Universal, Isolator and the 802SB/901SB Sounder bases may be mounted only as just described. The 814RB relay base may be mounted as just described, or it may be plugged into a Universal or Isolator base to interpose between it and the detector.

5.2.2 Modules

The *MX* Modules are normally mounted within the enclosure of the equipment to which they connect, or in a cabinet, junction box or switch box. They can also be mounted in the *MX1* panel. They may be mounted on plastic standoffs (e.g., 4 x HW0130) on a gear plate or cabinet, or to a face plate that mounts on a double flush or surface box. A hole may be required for the on-board LED. A standard plate with a hole for the LED and three holes for the Service Tool is available (Ancillary Cover M520). This fits a plastic surface box K2142. Most modules can also be mounted in the IP65 rated D800 box.

The MIM800/801 is smaller than the other modules, and is supplied in a plastic housing which has a lug for screw mounting.

The MIO800 is physically larger than most modules and can be mounted in a D800 box or on a DIN rail mounting kit (part no. 557.201.303).

The VIGILANT *MX1* Loop Card/*MX* module mounting bracket (FP1027) provides mounting for *MX* Modules on the 19" rack cabinet *MX1* gear plate in place of *MX* Loop Cards. This bracket is supplied with the hardware required to mount the bracket and the *MX* modules, plus instructions. It has mounting for:

- 2 x standard-size *MX* Modules: CIM800, DDM800, DIM800, LIM800, LPS800, RIM800, SIO800 or SNM800; or
- 1 x MIO800 module.

The 4 x *MX*/DDM800 mounting bracket (FP1062) provides mounting for 4 x standard size *MX* modules and can be fitted on the *MX1* gear plate instead of bracket-mounted *MX* Loop Cards. It is supplied with mounting hardware and a screw terminal block.

A version of this bracket is available (FP1063) with 4 x DDM800 modules factory-fitted and wired to provide 8 conventional detector circuits. Up to 6 of these modules can be fitted (4 easily, 2 with more work) to the 15U *MX1* gear plate (with no T-GEN) to provide 48 circuits of conventional detection, e.g., for retrofit applications.

5.3 Address and LED Blink Programming

Addresses for *MX* detectors and modules, and options such as LED blink on poll, are most easily set using the 801AP *MX* Service Tool or 850EMT. These are set by placing the detector onto the Service Tool, or connecting the module to the Service Tool with the supplied ancillary lead, and programmed as per the *MX* Service Tool Instructions.

Also the *MX* Loop Tester or the *MX1*'s change address function can be used to automatically address devices as they are added to the loop one at a time.

For all input devices, including detectors, the LED turns on steady when in alarm. For output devices (RIM800, etc.) the LED turns on when the device is activated.

5.4 Detector Descriptions

5.4.1 850H

The 850H is an analogue heat detector. The detector senses the air temperature and sends this value to the *MX1*. The *MX1* makes any decisions as to whether this is an alarm, fault, normal, etc. The integral LED is turned on by the *MX1* when an alarm is detected.

Features:

- temperature sensing range of -25°C to 70°C (short term to 90°C)
- temperature accuracy typically $\pm 2^\circ\text{C}$
- can be configured to operate as an A2S, A2R, CS or CR heat detector
- in-built short circuit isolator (functions when fitted to a 4B-C base)
- remote LED and functional base outputs separately controllable
- can be remotely addressed using the 850EMT tool in IR mode.

5.4.2 850P

The 850P is a photoelectric smoke detector. The detector senses the amount of smoke present and sends this value to the *MX1*. The *MX1* makes any decisions as to whether this is an alarm, fault, normal, etc. The integral LED is turned on by the *MX1* when an alarm is detected.

Features:

- photoelectric smoke sensor
- in-built short circuit isolator (functions when fitted to a 4B-C base)
- remote LED and functional base outputs separately controllable
- can be remotely addressed using the 850EMT tool in IR mode
- operating temperature range -25°C to 70°C
- selectable detection algorithms.

5.4.3 850PH

The 850PH is a photoelectric smoke detector which also includes a temperature sensor. The detector senses the amount of smoke present and the temperature and sends these values to the *MX1*. The *MX1* makes any decisions as to whether this is an alarm, fault, normal, etc., based on the smoke level, temperature, or rate of rise of temperature, and/or a combination of these. The integral LED is turned on by the *MX1* when an alarm is detected.

Features:

- photoelectric smoke sensor
- heat sensor
- in-built short circuit isolator (functions when fitted to a 4B-C base)
- Remote LED and functional base outputs separately controllable
- can be remotely addressed using the 850EMT tool in IR mode
- operating temperature range of -25°C to 70°C
- selectable detection algorithms for smoke and heat sensors.

5.4.4 850PC

The 850PC is a multi sensor detector incorporating a photoelectric smoke sensor, a carbon monoxide (CO) sensor and a heat sensor. The detector senses the amount of smoke and carbon monoxide present and the temperature and sends these values to the *MX1*. The *MX1* makes any decisions as to whether this is an alarm, fault, normal, etc., based on the smoke level, CO level and temperature and/or a combination of these. The integral LED is turned on by the *MX1* when an alarm is detected.

Features:

- photoelectric smoke sensor
- CO sensor
- heat sensor
- operating temperature range of -25°C to 70°C
- in-built short circuit isolator (when fitted to a 4B-C base)
- remote LED and functional base outputs separately controllable
- can be remotely addressed using the 850EMT tool in IR mode
- selectable detection algorithms for the smoke, CO and heat sensors.

5.4.5 814P Photoelectric Smoke Detector

The 814P is a photoelectric smoke detector. The detector senses the amount of smoke present and sends this value to the *MX1*. The *MX1* makes any decisions as to whether this is an alarm, fault, normal, etc. The integral LED is turned on by the *MX1* when an alarm is detected.

The detector's remote LED and functional base outputs are separately programmable for their functionality.

5.4.6 814PH Photoelectric Smoke + Heat Detector

The 814PH is a photoelectric smoke detector which also includes a temperature sensor. The detector senses the amount of smoke present and the temperature and sends these values to the *MX1*. The *MX1* makes any decisions as to whether this is an alarm, fault, normal, etc., based on the smoke level, temperature, or rate of rise of temperature, and/or a combination of these. The integral LED is turned on by the *MX1* when an alarm is detected.

Refer to the description of the 814H for more details on the heat-sensing element of the 814PH.

The detector's remote LED and functional base outputs are separately programmable for their functionality.

5.4.7 814CH Carbon Monoxide + Heat Detector

The 814CH is a carbon monoxide (CO) detector which also includes a temperature sensor. The detector senses the amount of CO present and the temperature and sends these values to the *MX1*. The *MX1* makes any decisions as to whether this is an alarm, fault, normal, etc., based on the CO level, temperature, or rate of rise of temperature, and/or a combination of these. The integral LED is turned on by the *MX1* when an alarm is detected.

Refer to the specifications of the 814H for more details on the heat sensing element of the 814CH.

The detector's LED and functional base outputs are separately programmable for their functionality.

5.4.8 814I Ionisation Smoke Detector

The 814I is an ionisation smoke detector. It should be avoided in new installations as only limited quantities are available for service requirements, and there may be long-term difficulties with eventual disposal. The detector senses the amount of smoke present and sends this value to the *MX1*. The *MX1* makes any decisions as to whether this is an alarm, fault, normal, etc. The integral LED is turned on by the *MX1* when an alarm is detected.

The detector's remote LED and functional base outputs are separately programmable for their functionality.

5.4.9 814H Heat Detector

The 814H is an analogue heat detector. The detector senses the air temperature and sends this value to the *MX1*. The *MX1* makes any decisions as to whether this is an alarm, fault, normal, etc. SmartConfig templates have heat profiles for AS 1603.1 Type A, B, C or D heat detection.

The 814H has a temperature sensing range of -25°C to 95°C. The approved operating temperature range is -10°C to +70°C. The accuracy of the 814H (as interpreted by the *MX1*), within the range 0°C to 70°C, is typically + / - 2°C.

The detector's remote LED and functional base outputs are separately programmable for their functionality.

5.4.10 801F Flame Detector

The 801F is a single spectrum infrared flame detector that can be mounted in the same base as the other 800 series detectors.

It has an integral LED that is turned on by the *MX1* when an alarm is detected.

It does NOT have remote LED and functional base controlling outputs.

5.4.11 VLC-800MX VESDA LaserCOMPACT

The VLC800MX is a derivative of the standard VESDA LaserCOMPACT, with the primary difference that it communicates directly on the *MX* Loop.

VESDA LaserCOMPACT detectors provide very early warning of potential fire conditions by drawing air samples through 25mm pipe up to 80m long. Smoke is sampled through holes in the pipe and transported to the detector by an integrated aspirator or fan. Holes are positioned according to the application and often follow the spacing of standard conventional point detectors. Where necessary, sampling points can be constructed using capillary extensions.

The *MX1* reads a value as the fraction of the obscuration level set within the VLC800MX and determines the point alarm state by comparing this value with the configured thresholds. A pre-alarm condition based on these thresholds is also available. The *MX1* has two sets of thresholds which it compares this value against. The comparison result against each set of thresholds appears as a separate sub-point of the VLC800MX. The default profiles for these thresholds are for "Fire" and "Major Fire".

The VLC800MX alarm sensitivity can be set to anywhere between 0.005% obscuration/m and 20% obscuration/m. A PC plugged into the VLC800MX is required to set the sensitivity, to normalise the airflow, and perform other setup functions. This sensitivity is NOT controlled at the *MX1*.

Refer to publication 17A-03-VLC for further details on installing, commissioning and servicing the VLC800MX.

5.4.12 FV411f / FV412f / FV413f Flame Detector

The FV411f, FV412f, and FV413f are triple waveband infrared flame detectors that are flameproof rated for installation in hazardous areas. The FV412f and FV413f have a built-in CCTV camera with PAL and NTSC outputs respectively.

Unlike other detectors, the FV400 series detectors are standalone units and do not mount in a base. The detectors include a remote LED output, but there is no control for this in *MX1*, and there is no functional base output.

Refer to the FLAMEVision FV400 Series – Triple IR Flame Detectors Product Application and Design Information Manual (120.515.123) and FV400 Series Triple IR Flame Detectors Fixing Instructions (120.515.124_FV-D-400-F) for further details.

5.4.13 S271f+ Flame Detector

The S271f+ is a triple waveband infrared flame detector that is rated for installation in hazardous areas.

Unlike other detectors it is a standalone unit as it does not mount in a base. Although the S271f+ includes a remote LED output there is no control for this in *MX1* and there is no functional base output.

Refer to the S200+ Series Triple IR Flame Detectors User Manual (120-415-400) for further details.

5.5 Detector Algorithms

The 801, 814 and 850 series of detectors support various detection algorithms for use in different applications.

Note: * indicates default algorithm.

Table 5.2 – Detector Algorithms

Algorithms – Heat Sensor

Algorithm	Description	Supported By	Application
Type A AS1603.1	63 degC alarm plus ROR alarm	814PH 814H 814CH*	Low ambient temperature not exceeding 45°C and not rapidly fluctuating.
Type B AS1603.1	63 degC alarm	814PH* 814H* 814CH	Normal temperature application 15°C to 45°C and potentially rapid fluctuating temperatures (> 6K/minute, e.g. commercial kitchens).
Type C AS1603.1	93 degC alarm plus ROR alarm	814H	Wide ranging temperatures <15°C to 75°C but not rapidly fluctuating.
Type D AS1603.1	93 degC alarm	814H	15°C to 75°C and potentially rapid fluctuating. (> 6K/minute, e.g. commercial kitchens).
Count 57C	57degC Count of 3, for EN-54 devices	801PHEX* 801CHEX* 801HEX*	Hazardous area zones up to 45°C without rapid fluctuating temperatures (<6K/min).
CR	Class CR, 91degC with ROR	801HEX	Hazardous area zones up to 75°C without rapid fluctuating temperatures (<6K/min).
Universal 63C	Class A2S 63 degC. No ROR	850PC	Normal temperature application 15°C to 45°C and potentially rapid fluctuating temperatures (> 6K/minute, e.g. commercial kitchens).
Resilient 63C	Class A2S 63 degC. No ROR	850PC*	
A2R 63C	Class A2R 63 degC with ROR	850H 850PC 850PH	Low ambient temperature not exceeding 45°C and not rapidly fluctuating.
A2S 63C	Class A2S 63 degC. No ROR	850H* 850PC 850PH*	Normal temperature application 15°C to 45°C and potentially rapid fluctuating temperatures (> 6K/minute, e.g. commercial kitchens).
CR 88C	Class CR, 88degC with ROR	850H	Normal temperature application not exceeding 75°C and not rapidly fluctuating. Un-air-conditioned sky light.
CS 88C	Class CS 88 degC. No ROR	850H	Normal temperature application not exceeding 75°C and potentially rapid fluctuating temperatures (> 6K/minute, e.g. commercial kitchens).

Algorithms – Smoke Sensor (Photo)

Algorithm	Description	Supported By	Application
FastLogic High	FastLogic High Sensitivity	850PH 850P 814PH 814P	High value assets in clean areas such as computer rooms.
FastLogic Med	FastLogic Medium Sensitivity	850PH* 850P* 814PH* 814P*	Residential, excluding laundries and kitchens. Smoke hazard management (AS 1668).
FastLogic Low	FastLogic Low Sensitivity	850PH 850P 814PH 814P	Residential, Commercial and Industrial with transient contaminant from steam, cooking fumes, etc.
FastLogic High Enh	FastLogic High Sensitivity, heat enhanced	850PH 814PH	Same as for FastLogic High, but where there is a higher than normal flaming fire risk.
FastLogic Med Enh	FastLogic Medium Sensitivity, heat enhanced	850PH 814PH	Same as for FastLogic Med, but where there is a higher than normal flaming fire risk.
FastLogic Low Enh	FastLogic Low Sensitivity, heat enhanced	850PH 814PH	Same as for FastLogic Low, but where there is a higher than normal flaming fire risk.
Count High Sens	Count of 3, high sensitivity	850PH 850P 801PHEX	High value assets in a clean stable environment requiring a fast transient response and/or hazardous areas.
Count Normal	Count of 3, normal sensitivity	850PH 850P 801PHEX*	Normal asset protection requiring a fast transient response and/or hazardous areas. Used for D51MX Duct Sampling Unit.
Count Low Sens	Count of 3, low sensitivity	850PH 850P 801PHEX	Normal asset protection with some background air borne contaminants requiring a fast transient response and/or hazardous areas.
Count High Sens Enh	Count of 3, high sensitivity, heat enhanced	850PH	Same as for Count High, but where there is a higher than normal flaming fire risk.
Count Normal Enh	Count of 3, normal sensitivity, heat enhanced	850PH	Same as for Count Med, but where there is a higher than normal flaming fire risk.
Count Low Sens Enh	Count of 3, low sensitivity, heat enhanced	850PH	Same as for Count Low, but where there is a higher than normal flaming fire risk.
8%	SmartSense 8%/m Obscuration	814PH 814P	Special high sensitivity in clean environments.
12%	SmartSense 12%/m Obscuration	814PH, 814P	General use including smoke hazard management with high transient immunity to cooking fumes.
8% Enh	SmartSense 8%/m Obscuration, heat enhanced	814PH	Special high sensitivity in clean environments with high flaming fire risk.

Algorithm	Description	Supported By	Application
12% Enh	SmartSense 12%/m Obscuration, heat enhanced	814PH	General use including smoke hazard management with high transient immunity to cooking fumes but with high flaming fire risk.
Universal	Normal sensitivity smoke, heat and CO algorithm	850PC	Residential and commercial with unpredictable fire risk and deceptive (non-fire) phenomena.
Resilient	Reduced sensitivity smoke, heat and CO algorithm	850PC*	Industrial requiring a high degree of deceptive phenomena resistance.
HPO	Increased sensitivity smoke detection only, with heat enhancement	850PC	Reserved
HPR	Heat-enhanced Photoelectric smoke - reduced sensitivity	850PC	Reserved
Smoke Disabled		850PC	Temporary setting for use during building construction.

Algorithms – Smoke Sensor (Ionisation)

Algorithm	Description	Supported By	Application
0.22 MIC X	SmartSense 0.22 MIC X	814I	Replacement for existing ionization smoke detector.
0.39 MIC X	SmartSense 0.39 MIC	814I*	Replacement for existing ionization smoke detector.
0.59 MIC X	SmartSense 0.59 MIC X	814I	Replacement for existing ionization smoke detector.
Count Low Sens	Count of 3 Low Sensitivity	814I	Reserved
Count Normal	Count of 3 Normal Sensitivity	814I	Reserved
Count High Sens	Count of 3 High Sensitivity	814I	Reserved

Algorithms – CO Sensor

Algorithm	Description	Supported By	Application
23ppm	SmartSense 23 ppm CO	814CH	High value asset protection well removed from the combustion process.
38ppm	SmartSense 38 ppm CO	814CH	Normal life safety protection against slow smouldering fire risks and alternative to smoke detection where smoke like deceptive phenomena is produced, e.g. theatrical smoke.
66ppm	SmartSense 66 ppm CO	814CH	Replacement for smoke detection to generate a general fire alarm where cigarette smoking is permitted.

Algorithm	Description	Supported By	Application
23ppm Enh	SmartSense 23 ppm CO, Heat enhanced	814CH	As for SmartSense 23ppm CO, but with a high flaming fire risk.
38ppm Enh	SmartSense 38 ppm CO, Heat enhanced	814CH	As for SmartSense 38ppm CO, but with a high flaming fire risk.
66ppm Enh	SmartSense 66 ppm CO, Heat enhanced	814CH	As for SmartSense 66ppm CO, but with a high flaming fire risk.
Count High Sens	Count of 3 High Sensitivity	801CHEx	High smouldering fire risk in hazardous areas with no background CO.
Count Normal	Count of 3 Normal Sensitivity	801CHEx*	Normal smouldering fire risk in hazardous areas.
Count Low Sens	Count of 3 Low Sensitivity	801CHEx	Normal smouldering fire risk in hazardous areas with higher than normal background CO.
Universal	Normal sensitivity CO algorithm	850PC	Residential CO algorithm.
Resilient	Reduced sensitivity CO algorithm	850PC*	Industrial or high background CO, or used for local alarm activation only.
Toxic Gas	Time integrating CO Toxic Gas alarm	850PC	Residential where gas and oil heating appliances are used in combination with normal smoke and heat detection.
CCO 850PC	Normal sensitivity CO algorithm with heat enhancement	850PC	Used when smoke sensor is disabled in the 850PC.
Count 66ppm	Reduced sensitivity CO algorithm	850PC	Used when smoke sensor is disabled in the 850PC. Suitable for when there are slightly higher background CO levels.
CO Disabled		850PC	Used where transient CO levels make CO sensing unsuitable.

5.6 Detector Base Descriptions

5.6.1 Universal Bases

The 4B 4" Universal Base and the 5B 5" Universal Base accommodate any of the MX 814 or MX 850 series detectors.

Wiring of the Universal Base is shown in Figure 5.1.

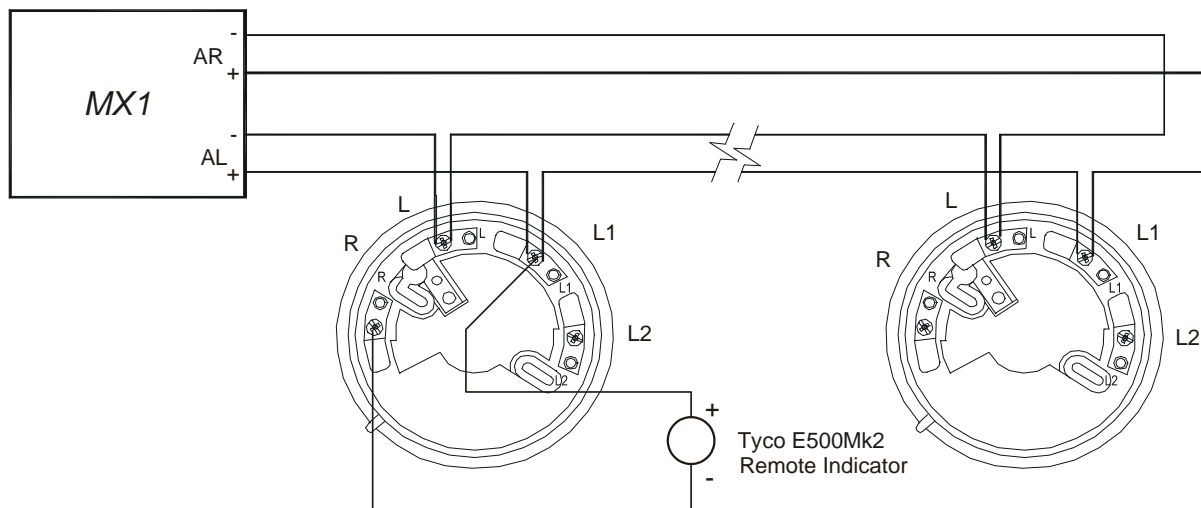

Figure 5.1 – Wiring for Universal, Relay and Sounder Bases

5.6.2 Isolator Bases

The 4B-I 4" Isolator base and the 5BI 5" Isolator base are designed for isolating short circuited sections of the analogue loop. Typically these are used where the loop wiring crosses zone boundaries, to prevent a short circuit from affecting more than one zone. Refer to Figure 5.2 for wiring details. When isolator bases are used and the MX1 Controller Board is PA1011 or the MX Loop Card is Rev 1 or 2, it is strongly recommended that two additional isolator bases (possibly with no detectors inserted) or LIM800s be installed at the start and end of the loop, close to the MX1. With the PA1081 MX1 Controller and V1.40 firmware onwards, and MX Loop Cards Rev 3 onwards, there is no need for these isolators at the start and end of each loop as the cards have in-built isolators.

Isolator bases or LIM800s may also be used to join multiple lines together in a single star arrangement, for example when a number of conventionally wired zones are being converted to MX devices and a loop cannot be wired. Refer to Chapter 6 for loop design information.

There is a limit to the number of devices that may be connected to each section of cable between isolator bases. Use MX1COST to check this.

The LIM800 module is described in Section 5.8.1.

When an 850 series detector is installed in a 4B-C base the detector provides an in-built short circuit isolator equivalent to the isolator base or LIM800. See Section 5.6.3. If the 850 series detector is installed in a 4B/5B base, sounder base, or relay base the in-built isolator is bypassed and not used.

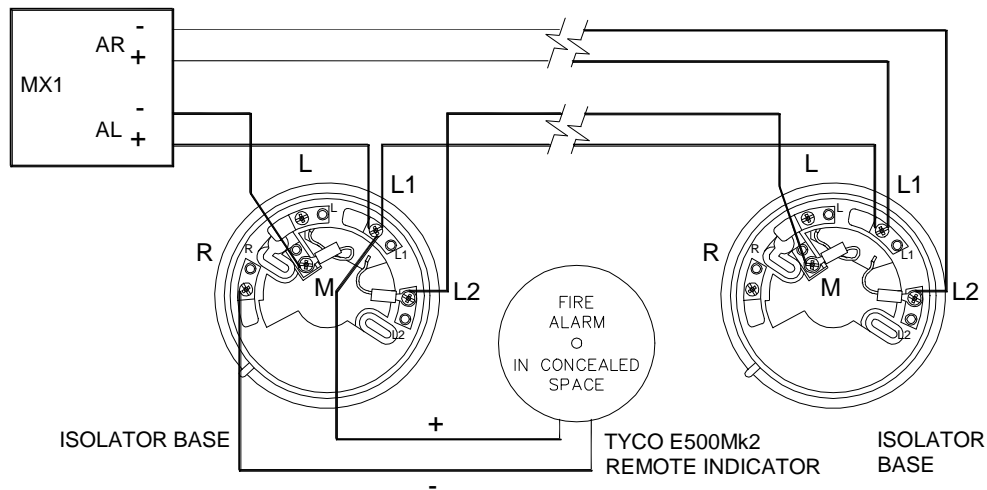

Figure 5.2 – Isolator Base Wiring

5.6.3 Continuity Base

The 4B-C Continuity base is used with only 850 Series detectors as these have an in-built short circuit isolator. The 4B-C base provides continuity for the loop when the detector is removed.

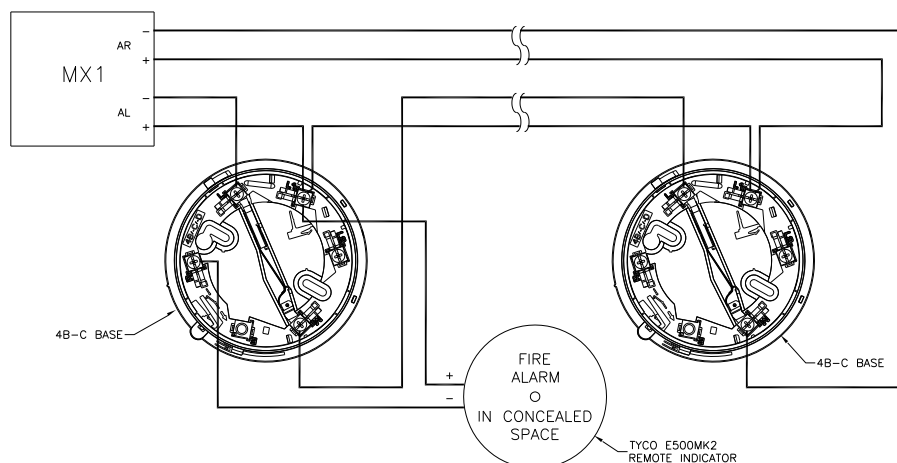

Figure 5.3 – 4B-C Continuity Base Wiring

5.6.4 814RB Relay Base

The 814RB Relay Base is a loop-powered output device. The relay is controlled by the device which is plugged into the base, but the operation of the relay can be quite separate from the operation of the detector.

The 814RB Relay Base provides two sets of non-supervised voltage-free, change-over contacts capable of switching ancillary equipment rated at up to 1A resistive at 30VDC. One set is labelled NO, C, NC (for normally open, common, and normally closed). The other set is labelled 1 for NC, 2 for C, and 3 for NO (see Figure 5.4). The terminals accept a single cable of up to 2.5 mm². Relay operation is controlled by the MX1 via an output from the device. Hence, a device **must** be fitted to the base in order for the relay to operate since the relay base does not have its own address.

The 814RB may be plugged into a Universal or Isolator Base, or mounted directly on the ceiling.

Wiring of the *MX* Loop to the 814RB is shown in Figure 5.1, and the relay terminals are shown in Figure 5.4.

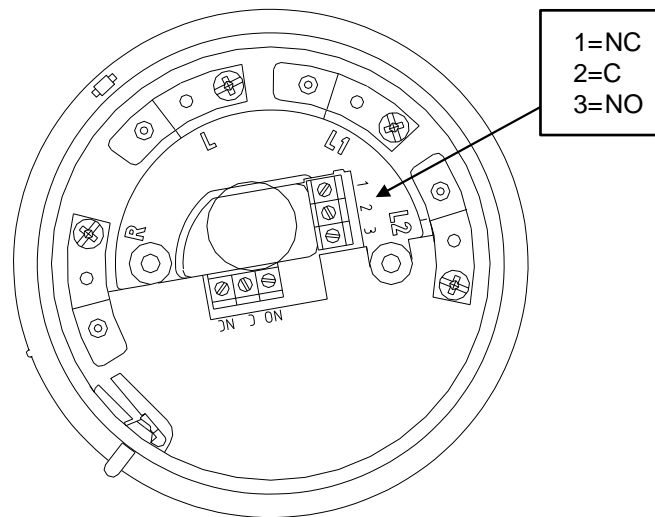

Figure 5.4 – Relay Base

5.6.5 802SB/812SB Sounder Bases

The 802SB/812SB sounder bases are loop-powered sounder bases that provide a higher volume at a generally lower current than the older 814SB. These bases are not AS 7240.3 compliant, and are replaced by the 80DSB. Refer Section 5.6.8.

The 802SB has a choice of 8 tone types and a volume control, and provides 90dBA of sound level typically.

The 812SB has a similar choice of tones, but has a fixed sound level of 100dBA.

The loop loading of the 812SB is significantly higher than other devices.

These sounder bases need to be mounted to the ceiling directly, as they do not mount into another base. Wiring is as per the standard base, refer Figure 5.1.

5.6.6 901SB Sounder Base

The 901SB sounder base is a *MX* loop compatible sounder base that requires an external 18-32Vdc supply. Its loop loading is much lower than the 802SB, and so more can be handled per loop. This base is not AS 7240.3 compliant.

The 901SB has a choice of 8 tone types, volume control, and provides 90dBA of sound level typically.

The sounder base is controlled by the detector or SAB801/SAM800 plugged into it.

The sounder base needs to be mounted to the ceiling or wall directly, as it does not mount into another base. Wiring of the *MX* Loop is as per the standard base, refer Figure 5.1. Wiring of the external power source is to the + and - terminals.

5.6.7 Remote Indicator Wiring

A Vigilant E500 Mk2 remote indicator may be wired to any base as shown in Figures 5.1 to 5.3.

A single Remote Indicator may be wired up to a number of detector bases, so that it turns on if any one of the detectors turns it on. The R terminals of the detectors bases involved must be looped together.

This group must not include an isolator base or extend across an isolator.

The brightness may increase slightly if more than one detector turns on the remote indicator.

Note that this effect can also be achieved using logic equations in the configuration instead of wiring between the bases. There are no grouping limitations when using logic equations.

5.6.8 80DSB Sounder Base

The 80DSB Sounder Base is a non-addressable sounder base that is controlled by the functional base output of the detector/addressing module that is plugged into it. It conforms to AS 7240.3 and replaces the 802SB and older 814SB. It is configured via internal dip switches for the tone (one of 16) and volume (one of 4 settings – only 3 comply with AS 7240.3).

Wiring is as per the standard base, refer Figure 5.1. It does not include a short circuit isolator, and bypasses the SCI in any 850 detector plugged into the base. Therefore it should not be used as the first or last device on a zone if the loop wiring extends into another zone.

5.6.9 P80SB Addressable Sounder Base (AAD)

The P80SB Sounder Base is an addressable sounder base – it has its own address (1 of 250) and is controlled separately to any detector plugged into it. In fact a detector is not needed in the base (fit an B-CAP instead). It includes an MX loop short circuit isolator (SCI). It can produce one of 16 tones, and has a choice of two volume settings, that are set in SmartConfig.

It is wired as an isolator base – refer Figure 5.2.

5.6.10 P80AVB/P81AVB Sounder Beacon Base (VAD)

The P80AVB and P81AVB are addressable sounder/beacon bases – they have their own MX address (1 of 250) and are controlled separately to any detector plugged in. In fact they can be used without a detector fitted (install an B-CAP instead to cover the base internals). The sounder is controllable separately to the beacon via two sub-points in *MX1*.

The sounder supports a choice of one of 16 tones and two volume levels – these are selected via the profile chosen in SmartConfig. Note one tone must be selected for each device – it is not possible to dynamically change the tone with *MX1*. The beacon has a choice of two intensities and two flash rates. A combination of these is selected via the profile chosen in SmartConfig.

Use of the beacon, the higher intensity and a faster flash rate increases the alarm current consumption significantly.

The P81AVB includes a higher intensity beacon compared to the P80AVB (and draws more current when turned on). These devices include an in-built short circuit isolator. Wiring of the base is as per an Isolator Base – refer Figure 5.2.

5.6.11 P80AVR/P80AVW Addressable Wall-Mount Sounder Beacon (VAD)

The P80AVR and P80AVW are addressable wall-mount sounder/beacons. They have their own MX address (1 of 250), with two sub-points – one for the sounder and one for the beacon.

The sounder supports a choice of one of 16 tones and two volume levels. Note one tone must be selected for each device – it is not possible to dynamically change the tone with

MX1. The beacon supports a choice of two flash intensities and flash rates. A combination of these is selected via the profile chosen in SmartConfig.

Note use of the beacon, the higher intensity and a faster flash rate increases the alarm current consumption significantly. These devices include an in-built short circuit isolator, wiring is loop in, loop out using separate screw terminals.

5.7 Module Descriptions

5.7.1 MIM800 and MIM801 Mini Input Modules

The MIM800 and MIM801 Mini Input Modules are suitable for interfacing voltage-free contacts such as switches, relay contacts, flow switches, or non-indicating detectors.

The MIM800 supports both normally open and normally closed contacts, and the MIM801 supports normally closed contacts only when interrupt generation is required. Note that older MIM800s support only normally open interrupt generation.

Addressable Manual Call Point products are available that already incorporate the MIM800 or MIM801. Both the MIM800 and MIM801 may be used in normally open or normally closed configurations, and the normally open configuration can include short circuit fault supervision.

The normal response time to an input change of state is 0 – 5 seconds, as each device is polled at 5 second intervals by the *MX1*. If faster operation is required interrupt operation can be enabled. Interrupt operation allows a change to be signalled by the device so that the *MX1* detects the change almost immediately, rather than waiting for the next poll of the device.

The latest release of MIM800 supports interrupt on closing or opening contacts. The MIM801 supports interrupt on opening contacts only. An interrupt can be generated only on the transition from normal to alarm; transitions from alarm to normal will always require up to the poll interval to be recognised.

Fault supervision is provided by a 200Ω ELD resistor - open circuit fault in a normally-open configuration and short circuit fault in a normally closed configuration. In addition the normally-open configuration can be programmed to also generate fault on short circuit. In this case only one alarm contact is allowed and a 100Ω resistor must be wired in series with the alarm contacts. This same configuration can be used in a normally closed configuration to generate a fault on open circuit. Only a single contact can be used. Refer to Figure 5.5 for wiring configurations.

Note that the correct profile must be selected in SmartConfig to match the wiring. The input wiring must be as short as possible (<1m) and located well away from all electrical noise sources.

The MIM800 and MIM801 have screw terminals for an Alarm Indicator LED – such as the Vigilant E500 Mk2 remote indicator. No series resistor is required. A current of about 2.5mA will be supplied when the output is on.

WARNING
DO NOT JOIN INPUT WIRING BETWEEN MODULES OR CONNECT TO ANYTHING
OTHER THAN VOLTAGE-FREE CONTACTS

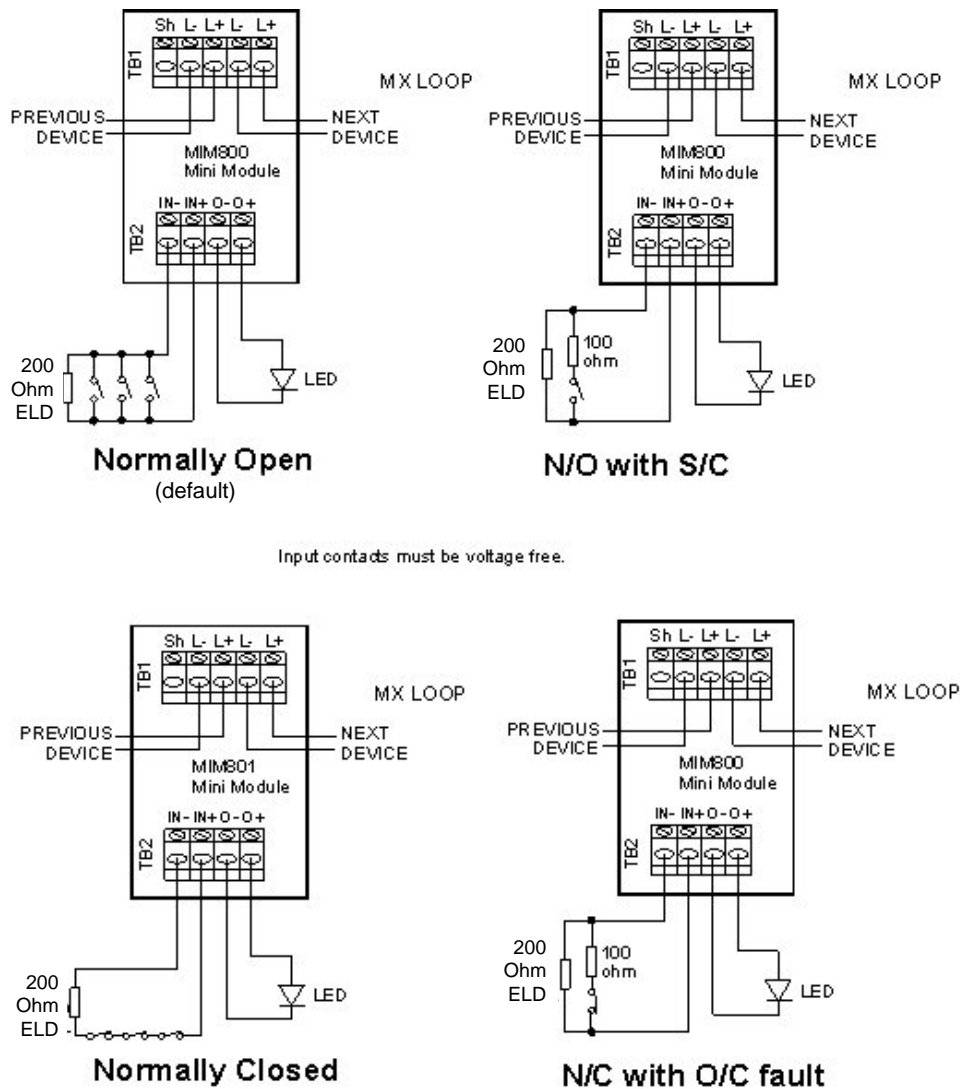

Figure 5.5 – MIM800 and MIM801 Field Wiring

5.7.2 CIM800 Contact Input Module

The CIM800 Contact Input Module is suitable for interfacing voltage free contacts, e.g. switches, relay contacts, flow switches, or non-indicating clean-contact detectors on longer input cables. It has two inputs, the state of which are separately available as sub-points.

The CIM800 may be used in normally open or normally closed configurations, and short and open circuit fault supervision can also be included.

The normal response time to an input change of state is 0 – 5 seconds, as each device is polled at 5 second intervals by the MX1. If faster operation is required, interrupt operation can be enabled. Interrupt operation allows a change to be signalled by the device so that the MX1 detects the change almost immediately, rather than waiting for the next poll of the device.

The CIM800 can interrupt only on “closing” contacts, so interrupt operation is applicable for only normally open contacts. Transitions from closed to open will always require 0-5 seconds to be recognised.

Fault supervision is provided by a 200Ω ELD resistor - open circuit fault in a normally-open configuration and short circuit fault in a normally closed configuration. In addition the normally-open configuration can be programmed to also generate fault on short circuit. In this case only one alarm contact is allowed and a 100Ω resistor must be wired in series with the alarm contacts. This same configuration can be used in a normally closed configuration to generate a fault on open circuit. Only a single contact can be used. Refer to Figure 5.6 for wiring configurations.

Note that the correct profile to match the wiring configuration must be selected for each input of the CIM800 in SmartConfig.

WARNING
DO NOT JOIN INPUT WIRING BETWEEN INPUTS OR MODULES OR TO ANYTHING OTHER THAN VOLTAGE-FREE CONTACTS

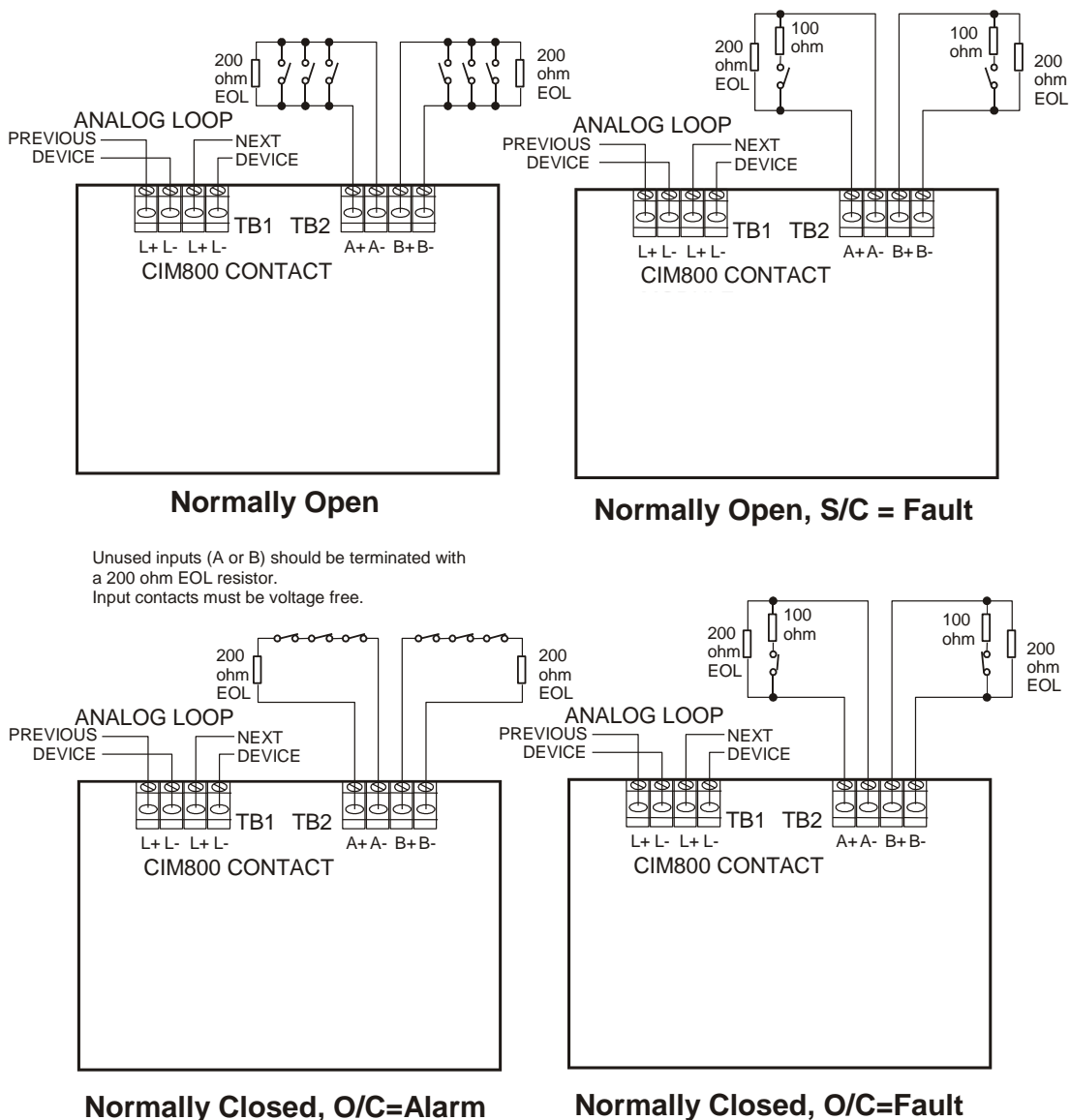

Unused inputs (A or B) should be terminated with a 200 ohm EOL resistor.
Input contacts must be voltage free.

Figure 5.6 – CIM800 Field Wiring

5.7.3 CP820/CP830/MCP820/MCP830 Manual Call Points

The CP820 and CP830 Manual Call Points consist of a MIM800 mounted on a standard Australian Break Glass Switch assembly. The MIM800 is factory-programmed with a different device type to allow the call points to be distinguished from a generic MIM800.

The MCP820/MCP830 call points have an internal electronics module that includes a short circuit isolator.

The CP830/ MCP830 is a weatherproof version of the CP820/ MCP820 suitable for external use (with suitable sunlight protection).

Default operation for the call points is to not use interrupts, but this can be enabled to give immediate indication of an alarm.

The call points are made without an ELD resistor and no wiring fault supervision is provided as all the wiring is internal.

The call points include an LED visible from the front. This lights on alarm and can be programmed to blink when the call point is polled.

5.7.4 DDM800 Universal Fire & Gas Detector Module

General

The DDM800 Universal Fire & Gas Detector Module is suitable for interfacing collective non-addressable detectors, e.g., smoke, heat, and MCPs, onto the *MX* loop.

The capabilities of the DDM800 are a superset of the DIM800 and it is suitable for use in a much broader range of applications. Additional features of the DDM800 include a built-in *MX* loop short circuit isolator, loop-powered operation, separate fast alarm band for an MCP and intrinsically safe circuit operation.

The DDM800 has two inputs, each of which can be set to be not used. No terminating EOL is required for a disabled input, thereby reducing power consumption.

Alarm and fault conditions are determined by the *MX1*. An alarm can be recognised within 5 seconds if AVF is not enabled for the circuit, or 15-20 seconds if AVF is enabled. Fast alarms (e.g. for MCPs) can be recognised nearly immediately if interrupts are enabled, or within 5 seconds otherwise. Recognition of a fault condition takes about 30 seconds.

A loop power mode can be programmed for the DDM800 module whereby the current to drive the collective detector circuits is derived from the *MX* loop – this functionality can eliminate the need for an expensive external power supply.

When the “low voltage” mode is selected (limits the compatible detectors to specific low voltage types) the *MX* loop voltage can work down to its usual minimum voltage of 20V. When any other mode is selected with loop powering the minimum *MX* loop voltage must be increased to 28V (requiring special *MX* loop design resulting in less loop load, shorter cables or thicker cabling be used). An external power supply will generally be used for modes other than low voltage modes.

The DDM800, when operating with an external supply, provides electrical isolation of the detector circuit(s) from the *MX* loop. If loop powered, this is not the case, the detector circuit –ve is common to the *MX* loop –ve.

If an external supply is used it must comply with AS 1670.1, and it should be set to 27.3V by default. The wiring from a common PSU to multiple DDM800 modules must be arranged so that a single open circuit does not prevent alarms from being generated in more than one

zone. A loop arrangement with supervision and a reverse-feed relay can be used to achieve this – refer to Product Bulletin PBF0200.

Battery calculations must take into account that a higher battery fail voltage than normal will be required for the DDM800 in external power mode – that is, the minimum DDM800 external supply voltage of 21.9V. MX1 systems without externally powered DDM800s are generally engineered for a battery fail voltage of 21.1V.

If the detector itself requires a 24V power supply that needs to be switched off to reset the detector, e.g. some beam detectors, refer to Product Bulletin PBF0213 for a suitable arrangement.

When the DDM800 power supply (external or loop derived) falls below a configured threshold a Load Supply Fail fault will be indicated. Processing of alarms or other faults will not occur whilst this condition exists. It is important that the loop design is done, otherwise the loop voltage could fall below this voltage and stop the DDM800 from working correctly.

A DDM800 internal fault is the highest priority fault and is presented simply as Fault. This will be generated when the DDM800 jumpers J2, J3, and J4 in the diagrams – they select the power source used. It will also be present when the DDM800 itself is genuinely faulty and requires replacement.

Detector Field Wiring

Field wiring of the DDM800 using loop power with collective detectors is shown in Figure 5.10. For collective detectors using an external power supply see Figure 5.9. For both setups, note the position of the jumpers J2, J3, and J4 in the diagrams – they select the power source used. The wiring instructions for the particular detector/base must be referred to as some bases break the negative line, and others the positive line, when the detector is removed. The EOL resistor value is 4k7 ±1%. Maximum line resistance is 50Ω, the detector circuit current limit is 25mA.

Wiring of an IS detector circuit to the DDM is shown in Figure 5.8. Apart from the IS repeater connection, follow all other aspects of Figure 5.7 or Figure 5.9 for loop and external powered modes respectively. The Pepperl+Fuchs KFD0-CS-Ex1.51P (single channel) or KFD0-CS-EX2.51P (two channel) IS repeaters are specified for IS operation with the DDM800. Note the use of a 5k6 ±1% EOL in this mode.

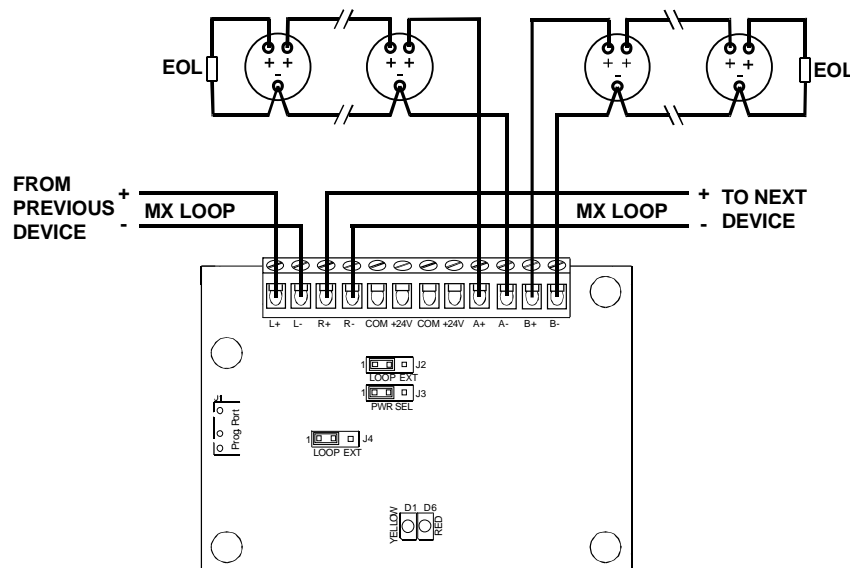

Figure 5.7 – DDM800 Field Wiring – Collective Detectors, Loop Powered

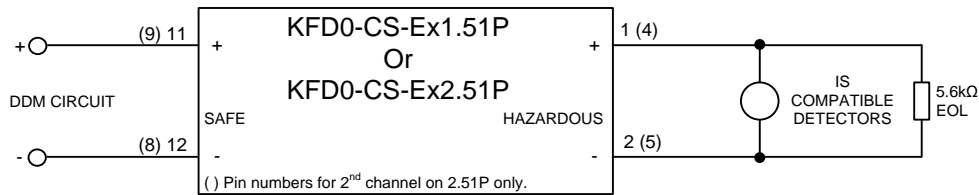

Figure 5.8 – DDM800 Field Wiring – IS Detectors

The FV421i Intrinsically Safe Flame Detector can be used in Conventional mode with a DDM800 on MX1. A P&F KFD2-CR-Ex1.30.200 Isolating repeater must be used on each DDM800 input, with an external power supply to the DDM800 (loop powering is not recommended). The DDM800 input must be configured for a profile of “Intrinsically Safe”. One FV421i is supported per DDM800 input, and the FV421i must be set for non-latching alarm operation as this arrangement does not provide a means to reset an alarm at the detector. Also, a short circuit in the hazardous area wiring will be detected as an alarm condition. Figure 5.8A shows the wiring for Input A.

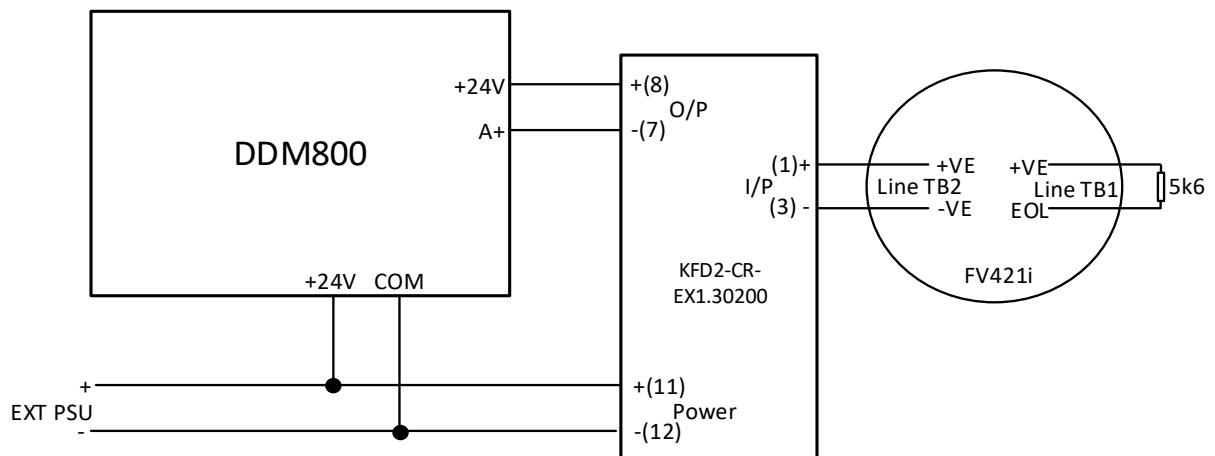

Figure 5.8A – DDM800 Wiring to FV421i Flame Detector

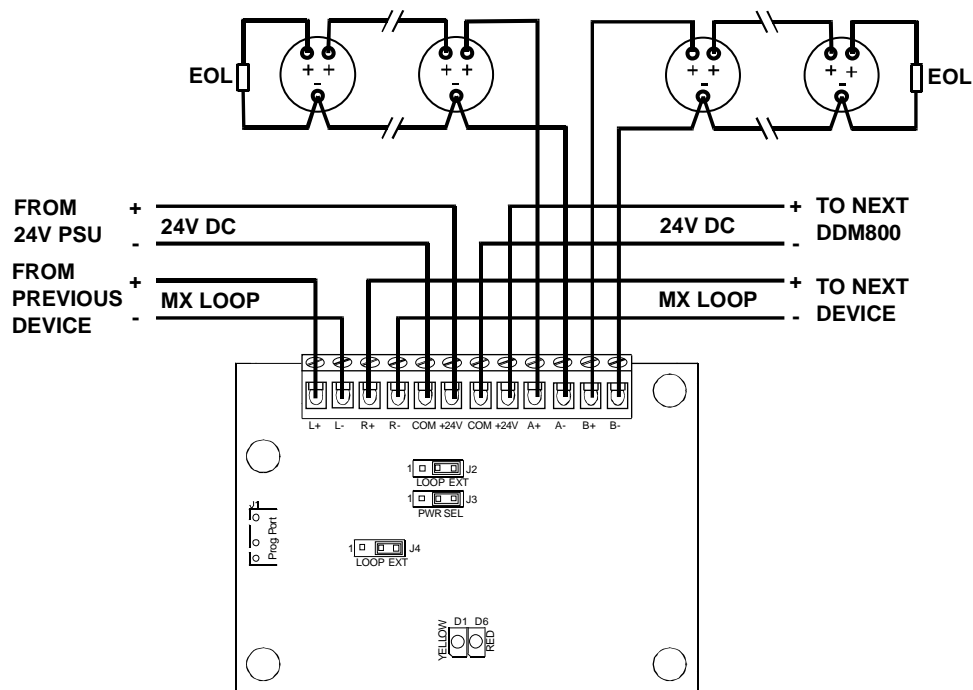

Figure 5.9 – DDM800 Field Wiring – Collective Detectors with External 24V Supply

Mode Selection and Applications

The DDM800 has a number of profiles in the default template available for selection. The Profile Selection Process (shown in Table 5.3) should be followed to determine the most appropriate profile. Consult the collective detector compatibility Table 5.4 for which collective detectors are compatible with each profile.

With the low voltage detector profile, the MX loop voltage may be run down to its normal level (20V). However, the range of compatible detectors suitable for this mode is less than for the standard voltage detector modes. Standard voltage detector modes require the MX loop voltage to be run at an elevated level (>28V) when loop-power is selected. Fortification of the MX loop, i.e., larger diameter cables, less load, and reduced cable length, will be required to meet this elevated minimum loop voltage.

The **Std Det, MCP, Int** profile defines separate alarm and fast alarm bands. This is to allow differentiation between smoke detectors (and others that fall into the detector alarm band) and MCPs which fall into the fast alarm band. The alarm and fast alarm bands for each input map to separate subpoints and so can be mapped to different zones. If there is no need to differentiate between alarm activation sources then both subpoints should map to the same zone.

The choice of profile should be performed on the principle of enabling the least functionality required for operation. For example, if no MCPs are present, then this functionality should not be enabled. The reasoning is that spurious voltages that fall into such bands won't give invalid operation.

An intrinsically safe detector profile is available for Ex-rated collective detectors used through an intrinsically safe current repeater. In this mode 15V MCPs may not be used, nor is a fast alarm band available.

The remote indicator outputs of detectors from different brands may be incompatible, so therefore, generally, detectors from different brands should not drive a common remote indicator. An exception to this is Minerva and MX detectors as they have the same remote indicator output.

Hard/clean contact devices must be rated for at least 30V, and currents up to 27mA.

Table 5.3 - Profile Selection Process

Application	Select Profile
New installation where no 15V MCPs are required and the detectors fitted will be selected from the Low Voltage Detectors. Use Table 5.4 Low Voltage Detectors, so as to avoid an external power supply or MX loop fortification.	Loop Pwr, Low V, No MCP (Use Low Voltage Detectors)
Existing installation with no MCPs is required, but a wide range of detectors is required.	Std Det, No MCP (Use Standard Voltage Detectors)
Installation where 15V MCPs are used/required.	Std Det, MCP, Int (Use Standard Voltage Detectors)
Hazardous environment requiring conventional Intrinsically Safe devices.	Intrinsically Safe (Use Intrinsically Safe Detectors)

Available Profiles

S/C is alarm and O/C is a fault condition for all the default profiles.

Profile Name	Interrupt	Det Alarm Band	Fast Alarm Band
Standard Voltage Detectors			
Std Det, No MCP	No	0 – 17.1V	-
Std Det, No MCP, Int	Yes	0 – 17.1V	-
Std Det, MCP, Int	Yes	0 – 13.8V	13.8 – 18.2V
Low Voltage Detectors			
Loop Pwr, Low V, No MCP	No	0 – 17.5V	-
Intrinsically Safe Detectors			
Intrinsically Safe	No	0 – 18.4V	-

Detector Compatibility

All Cerberus/Olsen detectors listed here for use with the DDM800 are compatible with the Z52B, Z54B, Z54B Mk2, Z56, and Z500 bases. In addition, the T56B heat detector is also compatible with the Z55B, Z56N, and Z500N bases.

Table 5.4 – DDM800 Detector Compatibility

Brand	Model	Type	Maximum No. per Circuit
Standard Voltage Detectors			
-	Hard Contact Devices (T54B, B111, etc.)		40

Kidde	Firewire	Linear Heat Detector	5000 metres
Olsen	C24B	Ionisation	40
Olsen	C29B	Ionisation	40
Olsen	P136	Duct Sampling Unit	7
Olsen	P24B	Photo	25
Olsen	P29B	Photo	20
Olsen	R23B	Flame	19
Olsen	R24B	Flame	12
Olsen	T56B	Heat	40
Protectowire	Protectowire	Linear Heat Detector	2000 metres
SAFE	ThermoCable	Linear Heat Detector	5000 metres
Simplex	4098-9601EA	Photo	25
Simplex	4098-9603EA	Ionisation	31
Simplex	4098-9618EA	Heat Type A	31
Simplex	4098-9619EA	Heat Type B	31
Simplex	4098-9621EA	Heat Type D	31
System Sensor	885WP-B	Weatherproof Heat Type B	40
Tyco	601F ¹	Flame	5
Tyco	601FEx ¹	Flame	5
Tyco	614CH	CO & Heat	35
Tyco	614I	Ionisation Smoke	40
Tyco	614P	Photo Smoke	40
Tyco	614T	Heat Type A, B, C, D	29
Tyco	SU0600	15V MCP	40
Tyco	FV411f	IR Flame Detector	3
Tyco	FV412f	IR Flame Detector	3
Tyco	FV413f	IR Flame Detector	3
Tyco	T614	Heat Type A, B, C, D	29
Tyco/Minerva	MD614	Heat	25
Tyco/Minerva	MF614	Ionisation Smoke	32
Tyco/Minerva	MR614	Photo Smoke	25
Tyco/Minerva	MR614T	HPO Smoke	21
Tyco/Minerva	MU614	CO	40
Low Voltage Detectors			
-	Hard Contact Devices (T54B, B111, etc.)		40
Kidde	Firewire	Linear Heat Detector	5000 metres
Protectowire	Protectowire	Linear Heat Detector	2400 metres
SAFE	ThermoCable	Linear Heat Detector	5000 metres
System Sensor	885WP-B	Weatherproof Heat Type B	30
Tyco	614CH	CO & Heat	21
Tyco	614I	Ionisation Smoke	25
Tyco	614P	Photo Smoke	25
Tyco	614T	Heat	17

¹ Not a CSIRO listed combination.

Intrinsically Safe Detectors			
-	Hard Contact Devices (T54B, etc.)		40
Kidde	Firewire	Linear Heat Detector	5000 metres
Olsen	C29Bex	Ionisation Smoke	24
Protectowire	Protectowire	Linear Heat Detector	2400 metres
SAFE	ThermoCable	Linear Heat Detector	5000 metres
Tyco	601FEx ¹	Flame	2
Tyco	MD601Ex ¹	ROR Heat	18
Tyco	MD611Ex ¹	Fixed Temperature Heat	18
Tyco	MDU601Ex ¹	Enhanced CO & Heat	12
Tyco	MF601Ex ¹	Ionisation Smoke	16
Tyco	MR601TEEx ¹	HPO Smoke	7
Tyco	MU601Ex ¹	CO	12
Tyco	S231i+ ¹	Flame	2
Tyco	FV421i	Flame (refer text)	1

5.7.5 DIM800 Detector Input Monitor

The DIM800 Detector Input Module is suitable for interfacing two circuits of 2-wire “20-Volt” conventional non-addressable detectors, e.g., heat detectors, smoke detectors, etc., onto the *MX* Loop.

Alarm and open/short circuit fault conditions are determined by the *MX1*.

The DIM800 provides electrical isolation of the detector circuit(s) from the *MX* Loop.

Refer to Figure 5.10 for wiring details.

The DIM800 requires an external supply to power the detector circuit(s) and the module itself. If external power is not provided the DIM800 will not respond to polls and a DEVICE FAIL fault will be indicated. The supervision of the external power supply is **only approximate**, i.e., it is only a go/no go indication. The DIM's power supply supervision may be Normal even though the supply voltage is less than the minimum for reliable detector operation. The voltage of the external supply at the DIM800 is critical to ensure compatibility with particular detectors. Refer to Table 5.5 for details. This shows the maximum quantity of each detector type per input circuit. When mixing detector types on a circuit the sum of each detector's quantity as a percentage of its maximum quantity must not exceed 100%.



The external supply cannot be derived from the *MX* Loop. Where the voltage range is critical, it is recommended that a dedicated power supply and battery be used. The voltage drop in the wiring from the power supply to the DIM800 must be calculated to ensure the supply voltage at the DIM800 is within specification. If multiple DIM800s are on the same cable, then the maximum current drawn by each DIM800, e.g., input short circuit, must be used.

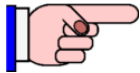

The external supply must meet the requirements of AS 1670.1 and should be set to 27.3V by default. The wiring from a common PSU to multiple DIM800 modules must be arranged so that a single fault does not affect more than 40 devices. A loop arrangement with supervision and a reverse-feed relay may overcome this under some circumstances – see Figure 5.19 later in Section 5.9.1.

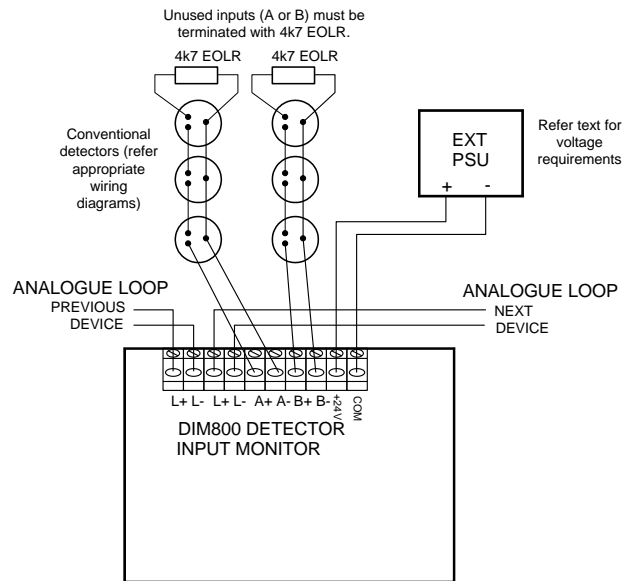

Figure 5.10 – DIM800 Field Wiring

Table 5.5 – DIM800 Detector Compatibility

Series	Model	Max Qty	External Supply Voltage at DIM800
Tyco	614P Photo Detector	25	20V – 28.7V
	614I Ionisation Detector	38	20V – 28.7V
	614CH combined CO and Heat Detector	32	20V – 28.7V
	614T Heat Detector	23	20V – 28.7V
	601FEx Flame Detector*	4	20V – 28.7V
	S231f+ IR Flame	7	21.0 – 28.7V
	FV411f IR Flame Detector	3	23.0 – 28.7V
	FV412f IR Flame Detector	3	23.0 – 28.7V
	FV413f IR Flame Detector	3	23.0 – 28.7V
Minerva	MD614 Heat Detector	40	20.7V - 28.7V
	MR614 Photo Detector	22	20.7V - 28.7V
	MR614T HPO Detector	21	20.7V - 28.7V
	MU614 CO Detector	40	20.7V - 28.7V
	MF614 Ionisation Detector	30	20.7V - 28.7V
	T614 Heat Type A, B, C, D	23	20.7V - 28.7V
Simplex	4098 – 9603EA Ionisation Detector	24	18.0V - 28.7V
	4098 – 9601EA Photo Detector	24	18.0V - 28.7V
	4098 – 9618EA,-9619EA,-9621EA Heat Detectors	24	18.0V - 28.7V
Olsen	P24B Photoelectric Detector	24	20.7V - 24.7V
	P29B Photoelectric Detector	20	20.7V - 26.7V
	C24B Ionisation Detector	40	20.7V - 26.7V
	C29B (Ex) Ionisation Detector	40	20.7V - 26.7V
	R23B Flame Detector	20	20.7V - 24.7V
	R24B Flame Detector	3	22.7V - 28.7V
	DO1101 Photo Detector	16	21.7V - 27.7V
	DLO1191 Beam Detector	1	22.7V - 28.7V
	P136 Duct Sampling Unit	5	19.0V - 28.7V
	T56B Heat Detector	40	18.0V - 28.7V
	All above Olsen Detectors with Z52B, Z54B, Z54B Mk2, Z56, Z500 base as appropriate		
T56B Heat Detector with Z52B, Z55B, Z56N, Z500N Base	40	18.0V - 28.7V	
Cerberus	DO1101 Photo Smoke	16	21.7 – 27.7V
	DLO1191 Beam Photo Smoke	1	22.7 – 28.7V
System Sensor	885WP-B Weatherproof Heat Detector	40	20V – 28.7V
	Hard Contact Devices (T54B, B111, etc)	40	18.0V - 28.7V
Hard contact devices must be rated for at least 30V and currents up to 50mA.			
* Although detector is Ex rated, this is a direct connection without an IS barrier			

5.7.6 LPS800 Loop-Powered Sounder Driver

The LPS800 MX addressable device provides a loop-powered controllable output that can supply up to 75mA to 24V rated load devices, such as sounders, relays, etc. It also provides supervision of the wiring to the load devices. Therefore each load device must have an integral series diode, or one must be fitted externally to allow the reverse voltage supervision to work. A 22k ELD resistor is required.

Figure 5.11 shows wiring details for the LPS800. Note that the external wiring can be arranged as a loop (Class A) so that an open circuit does not stop operation of the devices.

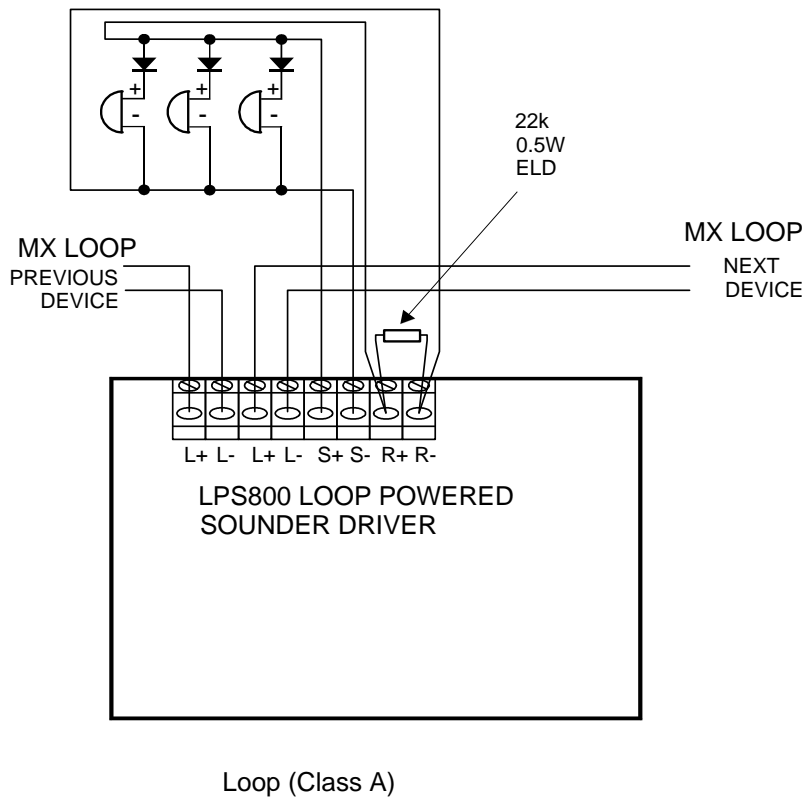
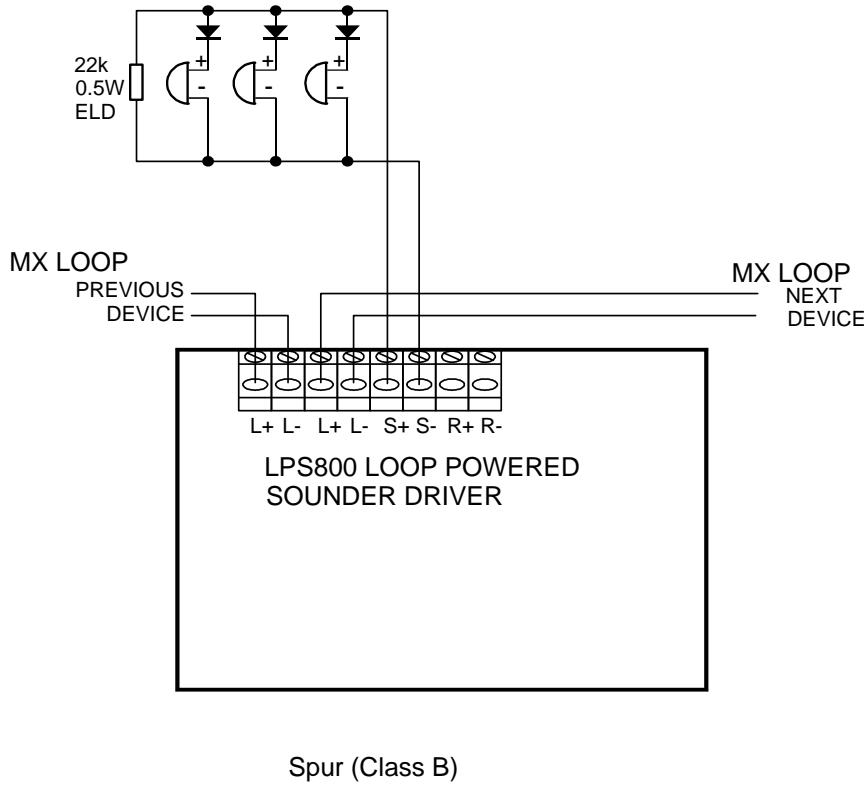

Figure 5.11 – LPS800 Field Wiring

5.7.7 MIO800 MULTIPLE I/O MODULE

The MIO800 is a Multi-Input/Output Module with three inputs and two outputs from latching relays.

The MIO800 is a different size to the CIM, DIM, RIM, etc., and will therefore require a different mounting arrangement.

It can be fitted into a D800 Ancillary Housing, may be DIN rail mounted, or fitted to a suitable electrical back box or standoffs on a gear plate. It may also be supplied fitted with a mounting bracket suitable for internal installation within a VESDA LaserPLUS or LaserSCANNER. This is called a VIO800 – part number 516.018.014.

Each input on the MIO800 supports one of the following modes.

- Multiple normally open contacts, closing for alarm, with o/c fault.
- A single normally open contact, closing for alarm with s/c and o/c faults.
- Multiple normally closed, open for alarm contacts with s/c faults.
- A single normally-closed contact, opening for alarm, with s/c and o/c faults.

Interrupt operation to speed up response is available on some configurations. As the MIO800 will interrupt on lowering resistance only (alarm or short circuit applied), it cannot be used for normally closed applications. Also, Input 3 does not support interrupt mode.

The MIO800 also includes two unsupervised change-over relay outputs, labelled Relay 1 and Relay 2, programmed in SmartConfig as Output 1 and Output 2 respectively. These relays can be programmed to provide on/off control outputs by writing suitable logic equations for them.

The MIO800 also has 4 logic level outputs labelled 01, 02, 03 and 04. Outputs 01 and 02 are the same signals as the two relay outputs. SmartConfig allows the configuration of 03 and 04, but as currently there are no compatible devices to wire to the 01... 04 outputs, these terminals must not be used.

The on-board LED will turn on when any input is in the alarm condition, and can be programmed to blink when the device is polled by the MX1 panel. Wiring of the MIO800 is shown in Figure 5.12.

When the MIO800 is added to a SmartConfig configuration the inputs are set for non-latching operation and the outputs have no functionality. These need to be programmed if required.

Relay Contact Rating: 2A d.c. @ 24VDC. The MIO800 must NOT be used to switch mains voltages.

Maximum Input Wiring Resistance: 40 ohms.

<p>WARNING DO NOT JOIN INPUT WIRING BETWEEN INPUTS OR MODULES OR TO ANYTHING OTHER THAN VOLTAGE-FREE CONTACTS</p>
--

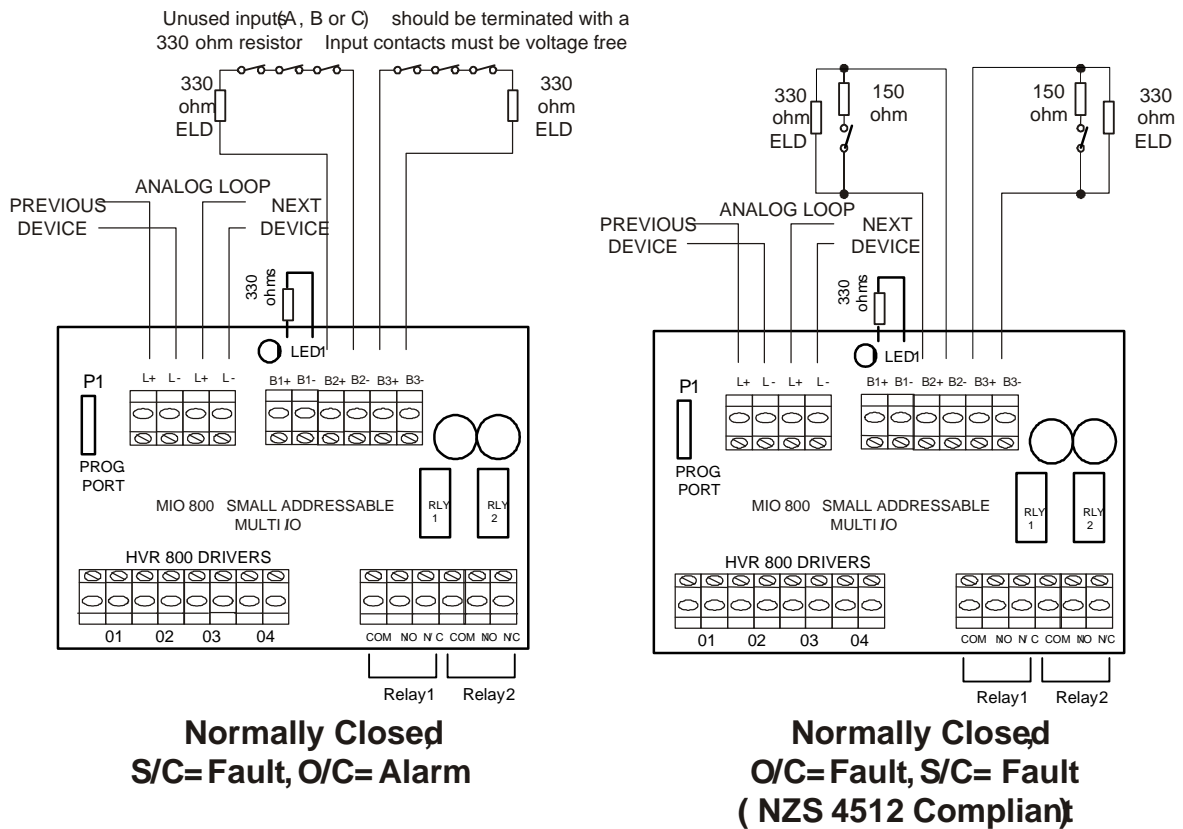
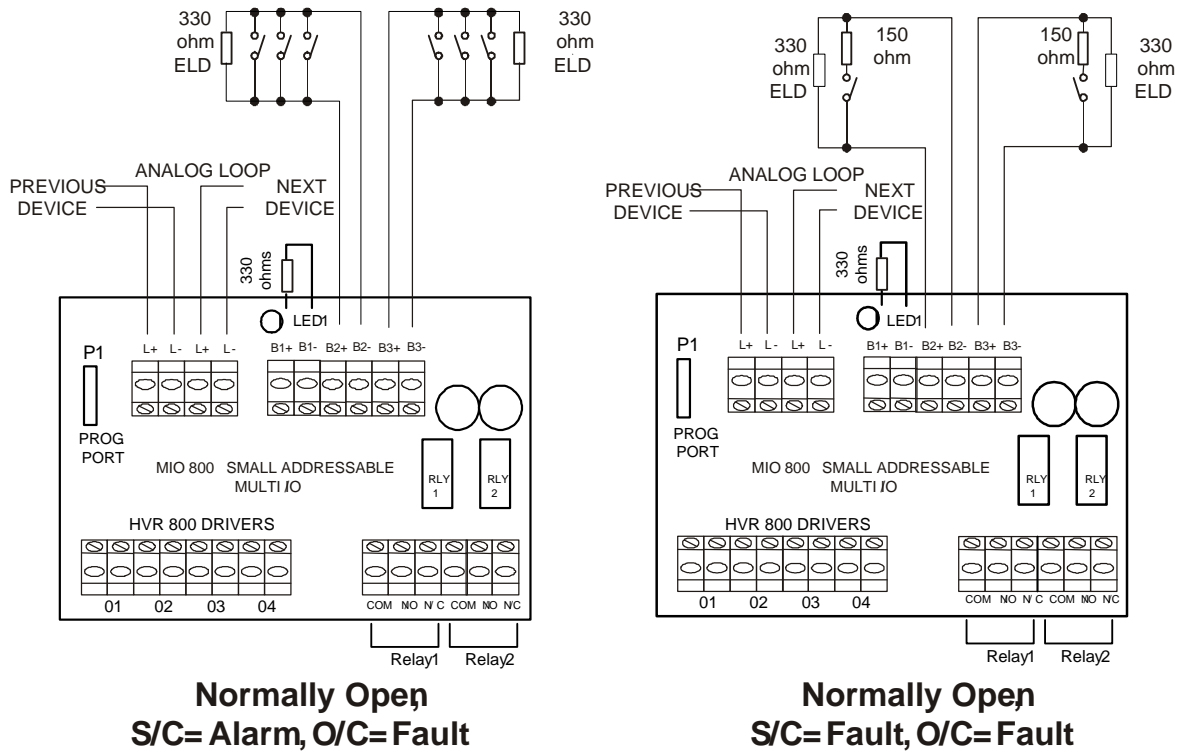

Figure 5.12 – MIO800 Wiring Diagrams

5.7.8 RIM800 Relay Interface Module

The RIM800 Relay Interface Module is suitable for providing control outputs which require clean voltage-free contacts and no supervision. For example, it can be used to signal states to other systems, e.g., BMS or security systems, or to energise loads that do not need to be supervised, e.g., Door Holders. Refer to Figure 5.13.

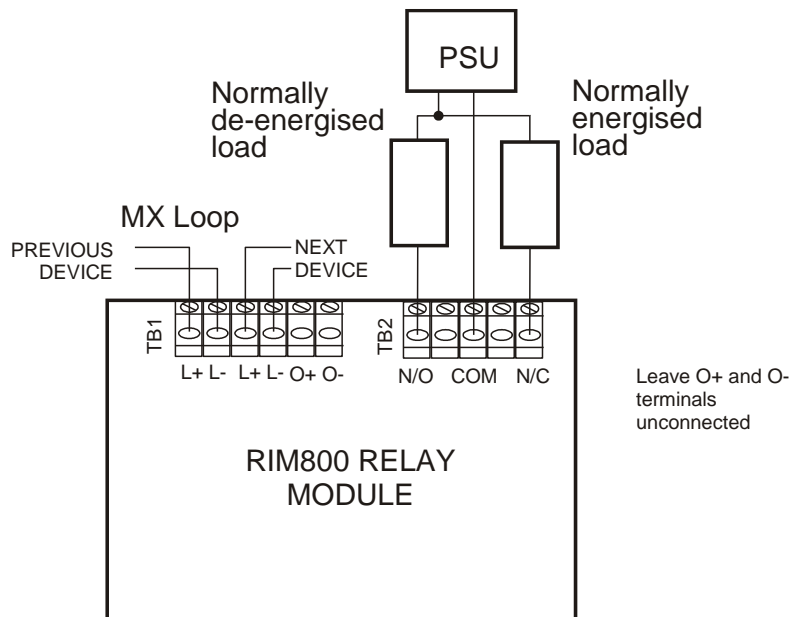

Figure 5.13 – RIM800 Field Wiring

5.7.9 SAB801 & SAM800

The SAB801 and SAM800 are MX addressable devices that provide a control output that can operate a sounder or relay base without the need to fit a detector. The SAM800 has a plain white front, whereas the SAB801 has a red LED beacon that can be controlled separately to the functional base output.

These devices simply plug into and control the sounder base (802SB, 901SB) or the relay base (814RB).

5.7.10 SNM800 Sounder Notification Module

The SNM800 Sounder Notification Module is suitable for providing a 2 Amp@24V energised output with optional supervision of the load wiring and d.c. power supply.

When inactive, a reverse polarity supervision voltage is applied to the load wiring. The load devices must therefore have internal or external reverse blocking diodes, if supervision is required.

The supervision can detect short and open circuit states on the load wiring only when the relay is inactive.

The load must be isolated from ground and all voltage sources. All inductive loads (e.g. bells or relays) must have back-emf diodes or other noise clamping devices fitted.

Supervision of the load and/or power supply is set by the profile selected in SmartConfig.

Refer to Figure 5.14.

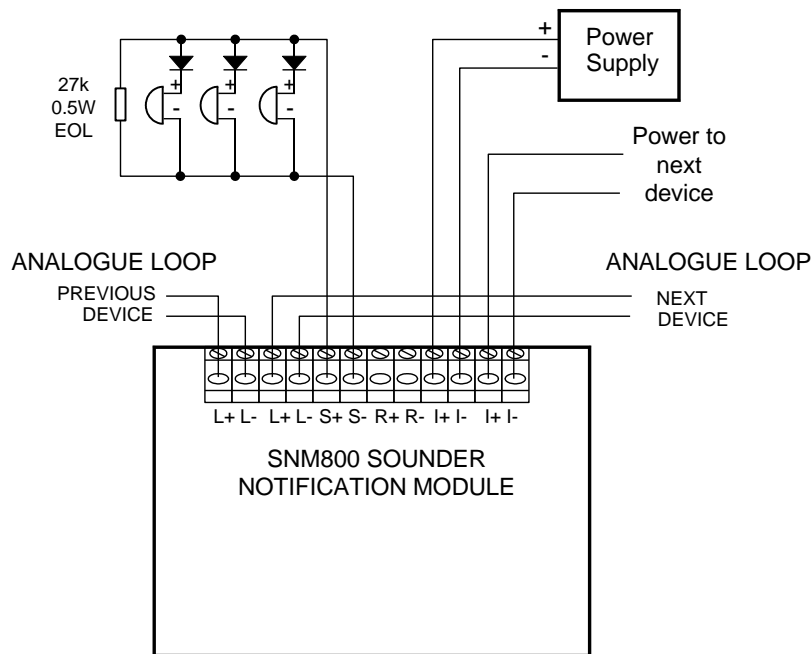

Figure 5.14 – SNM800 Field Wiring

5.7.11 QIO850 / QMO850 / QRM850 Quad Ancillary Modules

The Quad Ancillary Module range includes 3 models: QIO850, QMO850 and QRM850. The QIO850 has four monitored inputs with alarm and fault detection for clean contacts and four un-monitored outputs. Through jumper settings, the outputs can be changed between an auxiliary supply output or voltage free relay contacts. Fit links OUT1-4 in the AUX position (pins 2-3) when the output is to provide a switched 24Volts out (from Aux supply), and remove the links to provide clean contact relay outputs. Do not use the HVR position.

The QMO850 has four monitored outputs. Monitoring is provided by injection of a reverse polarity current through the wiring and the EOL resistor – this can't be disabled. The monitoring of the auxiliary supply voltage can be disabled through a jumper setting. There is no means to override the jumper setting through software. There is no capability to have voltage free contacts with this module. The output monitoring does not work unless an auxiliary supply is connected.

The QRM850 has four un-monitored outputs. Through jumper settings, the outputs can be changed between a switched auxiliary supply output or voltage-free relay contacts. Fit links OUT1-4 in the AUX position (pins 2-3) when the output is to provide a switched 24Volts out (from Aux supply), and remove the links to provide clean contact relay outputs. Do not use the HVR position.

Unmonitored relay outputs can be used to signal states to other systems. e.g., BMS or security systems, or to energise loads that do not need to be supervised, e.g., Door Holders.

The QIO850 and QRM850 modules don't require the auxiliary supply to operate the relays as voltage-free. When an auxiliary supply is connected it can be supervised. All the module outputs are capable of switching 2 Amp @24V loads.

All modules include a built-in MX loop short circuit isolator can be enabled or disabled through jumper settings.

The Quad ancillary modules are quite a different size and physical design compared to the other MX modules. They are supplied in a plastic enclosure designed for mounting directly

to 35mm top hat DIN rail. E.g., for example in an equipment interface box such as the ME0088 lockable IOR cabinet that is supplied with 3 DIN rails and mounting screws. Nine quad ancillary modules in total can be accommodated inside one of these cabinets.

Another suitable IP66 rated plastic enclosure is part number 557.201.410. It has a removable plastic cover and pop-outs for cabling – it contains a DIN rail inside suitable for one module.

Each input on the QIO850 supports one of the following modes:

- Normally open contact, closing for alarm, with o/c fault.
- Normally open contact, closing for alarm, with s/c and o/c fault.
- Normally closed contact, opening for alarm, with s/c fault.
- Normally closed contact, opening for alarm, with s/c and o/c faults.

All the modes have thresholds which are compliant with the AS7240.13 standard – largely this means standardised 10% tolerances for particular thresholds. Additionally, to meet a requirement of this standard, an additional fault band that is indicated as a non-specific fault is present for all modes to detect gradual increases in cable resistance e.g. due to contact corrosion.

For the QIO850 inputs, interrupt operation to speed up response is available for all configurations – both normally open and normally closed. It is separately available for each input.

For all modules, the LED, labelled POLL, will be lit when any output on the module is activated. In addition the LED OUT1 - OUT4 LED that corresponds to the activated output(s) will be lit. If more than the maximum number of *MX* devices have their LEDs on, then the LEDs will blink on some modules instead. No LED subpoint exists for the *MX* points of the quad ancillary modules. It is not possible to change what controls the module LEDs.

The *MX* loop short circuit isolator is monitored by the *MX1*, which will raise a fault on the .0 subpoint if the isolator opens. This will be logged as Isolator Fault. The ISO LED on the Quad Module will be lit when the *MX* line isolator is tripped by a short circuit.

The output relays of all the modules are monitored for becoming stuck (i.e., they are not in the commanded position). A checkback fault will be raised on the subpoint corresponding to the relay that is stuck.

For the QMO850 only, the outputs are monitored. Monitoring is provided by injection of a reverse polarity current through the wiring and the EOL resistor. The load devices must therefore have internal or external reverse blocking diodes. The load must be isolated from ground and all voltages sources. All inductive loads (e.g. bells or relays) must have back-emf diodes or other noise clamping devices fitted.

QMO850 short circuit monitoring is performed at a hardware level and this will inhibit the switching of the output relays. There is no way to disable this functionality. Short and open circuit states on the load wiring can be detected only when the relay is inactive.

There is no means to adjust the monitoring voltage threshold at the *MX1*. The only applicable voltage for this region that can be set by jumper is nominal 24 V. It must be set to this setting, as 48 V has no application in this region. The actual threshold is 18 volts +/- 1 volt.

The QIO850 and QRM850 have no jumper to enable/disable auxiliary supply monitoring. Each output for these modules has a corresponding subpoint with a selectable profile that allows enabling/disabling supervision of the auxiliary power supply.

There are four available profiles for the QMO850 output subpoints, these control whether EOL and/or auxiliary supply monitoring is enabled.

The QMO850 has a jumper to disable auxiliary supply voltage monitoring. If this is in the disabled position, then the enabling of voltage monitoring by the MX1 won't work as it won't be receiving the required data to perform monitoring.

Relay Contact Rating: 2A d.c. @ 30VDC. The quad ancillary modules must NOT be used to switch mains voltages.

Maximum Input Wiring Resistance: 50 ohms.

WARNING
DO NOT JOIN INPUT WIRING BETWEEN INPUTS OR MODULES OR TO ANYTHING OTHER THAN VOLTAGE-FREE CONTACTS

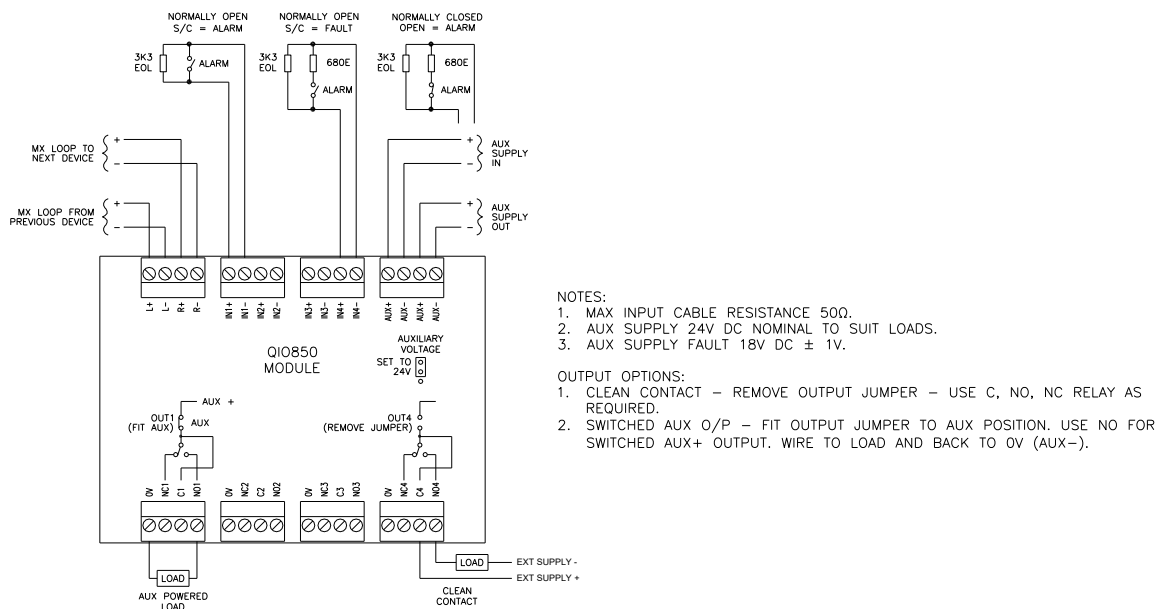
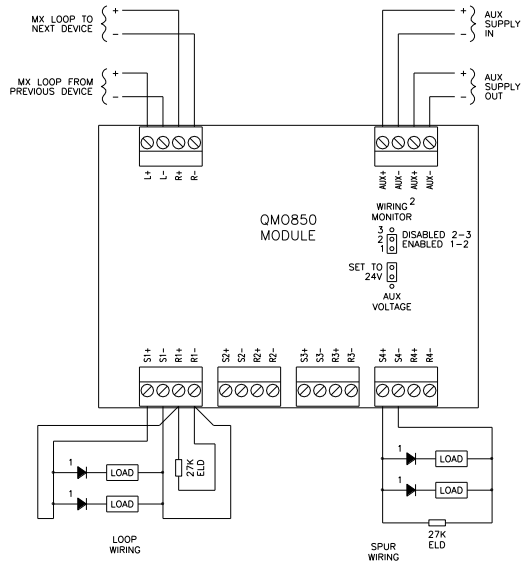
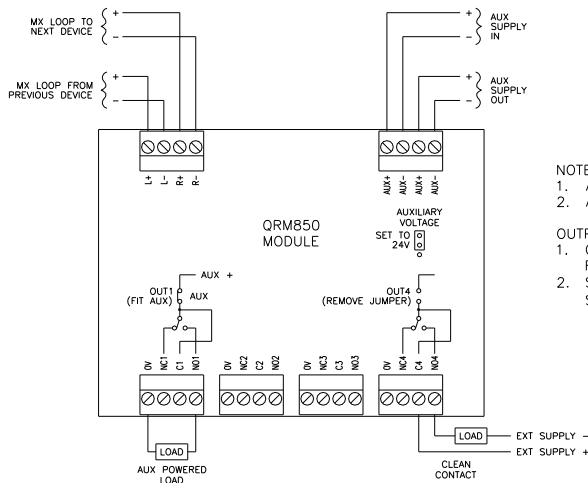

Figure 5.15 – QIO850 Field Wiring



- NOTES:
1. LOAD REQUIRES SERIES DIODE IF NOT FITTED INTERNALLY.
 2. FIT WIRING MONITOR JUMPER TO ENABLED (1-2) TO ENABLE SUPERVISION OF WIRING RESISTANCE TO AUX SUPPLY. FIT TO DISABLED (2-3) TO DISABLE.
 3. AUX SUPPLY 24V DC NOMINAL.
 4. AUX SUPPLY FAULT 18V ± 1V.

Figure 5.16 – QMO850 Field Wiring



- NOTES:
1. AUX SUPPLY 24V DC NOMINAL TO SUIT LOADS.
 2. AUX SUPPLY FAULT 18V DC ± 1V.
- OUTPUT OPTIONS:
1. CLEAN CONTACT – REMOVE OUTPUT JUMPER – USE C, NO, NC RELAY AS REQUIRED.
 2. SWITCHED AUX O/P – FIT OUTPUT JUMPER TO AUX POSITION. USE NO FOR SWITCHED AUX+ OUTPUT. WIRE TO LOAD AND BACK TO 0V (AUX-).

Figure 5.17 – QRM850 Field Wiring

5.7.12 SIO800 Single Input/Output Module

The SIO800 is a single input/output module with one input and one output from a latching relay.

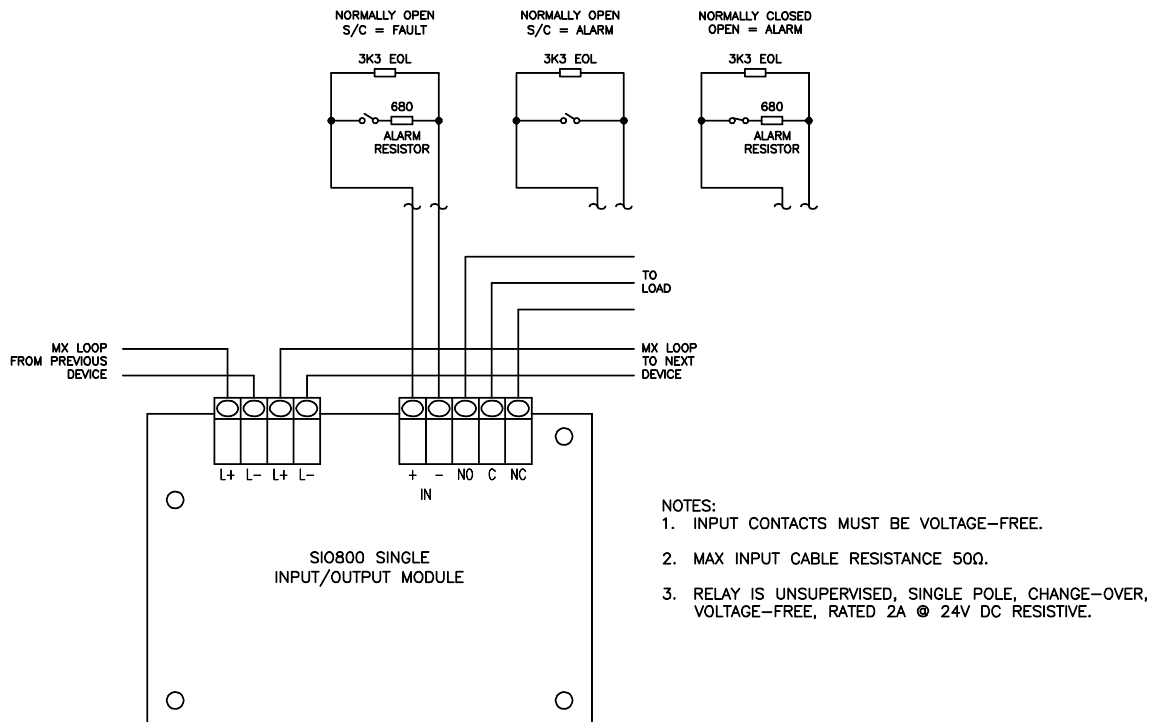

Figure 5.18 – SIO800 Field Wiring

Relay Contact Rating: 2Adc @ 24Vdc. The SIO800 must NOT be used to switch mains voltages.

Maximum Input Wiring Resistance: 50 Ohms

The single input on the SIO800 supports the connection of a clean contact device in the following modes:

- Normally open contact, closing for alarm, with O/C fault.
- Normally open contact, closing for alarm, with S/C and O/C fault.
- Normally closed contact, opening for alarm, with S/C fault.
- Normally closed contact, open for alarm, with S/C and O/C faults.

All the input modes have thresholds which are compliant with AS 7240.13 – largely this means standardised 10% tolerance for particular thresholds. Additionally, to meet a requirement of this standard, there is an additional fault baud that is indicated as a non-specific fault for all modes to detect gradual increases in cable resistance, e.g., due to contact corrosion.

Interrupt operation to speed up response is available for all modes – both normally open and normally closed.

The output is a change-over relay rated at 2A @ 24Vdc and is un-monitored and always voltage free. There is no provision for an auxiliary supply or load supervision.

The relay is monitored for becoming stuck (i.e., it is not in the commanded position). In this situation, a check-back fault will be raised.

WARNING
DO NOT JOIN INPUT WIRING BETWEEN INPUTS OR MODULES OR TO ANYTHING
OTHER THAN VOLTAGE-FREE CONTACTS

5.8 Other Devices

5.8.1 LIM800

The LIM800 is an *MX* Loop isolator module that can be used to provide short circuit isolation between zones and to a separate spur-wired zone of *MX* devices. It is functionally the same as the 5BI and 4BI isolator bases, but is packaged like most *MX* modules, and provides an additional spur output. This could be used to provide a fire-rated spur to a valve tamper device with a CIM800 or similar, for example.

Note that the Spur output, S+/S-, does not have its own short circuit isolator. Shorting this output will cause the two internal isolators to open and thus break the *MX* Loop. If better fault tolerance is required, use an additional isolator on the S+/S- output. For example, a second LIM800 with its S+/S- connected to the S+/S- connectors on the loop LIM800 will provide two separately short circuit isolated spur feeds off the loop (see Section 6.2.4).

Figure 5.18 shows the wiring of the LIM800.

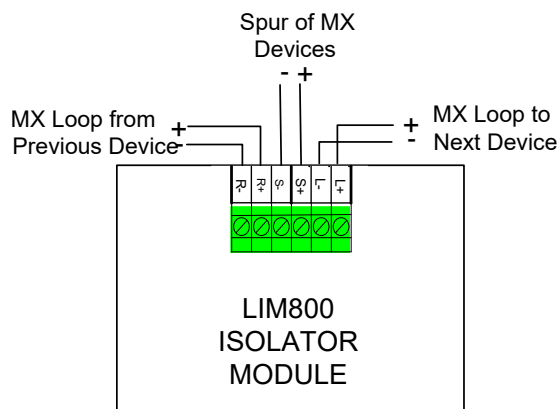

Figure 5.18 – LIM800 Wiring

5.9 Supervised Power Feed Wiring

5.9.1 Requirements

Australian fire alarm standards place requirements on system tolerance and supervision of wiring faults.

AS 1670.1:2015 & 2018 (Clause 2.6)

Requires that a short or open circuit (transmission path fault) affect no more than one detection zone.

Therefore MX devices that support more than one zone (e.g., CIM800, DIM800, DDM800) need to be loop-powered. Also, any power supply for DIM800 or DDM800 with two zones needs to be co-located, otherwise a power wiring fault to the device could disrupt more than one zone.

Therefore the following cannot be used for AS 1670.1:2015 & 2018 compliant systems.

AS 1670.1:2004 (Clause 2.6.2)

- Distributed parts of CIE with a total of more than 40 zones shall be connected to the FIP using two separate signal paths. Power cabling to distributed parts of CIE shall have the same integrity and redundancy as the signal paths.
- Any signal path fault or power supply fault (to distributed parts of CIE) shall indicate as a signal path or power supply fault.
- A single path fault or a single power supply fault shall not prevent the transmission of an alarm from more than forty devices.

These requirements can be met for the signal path on the addressable loop by appropriate use of isolators.

Where the detectors or devices in the field need an external supply, then these requirements also apply to the additional power wiring.

One way to meet these requirements is to wire separate (fused or current-limited) power feeds for each zone, but this could increase the cabling costs. An alternative approach is to wire the power feed to multiple devices in multiple zones in a loop arrangement as shown in Figure 5.19.

This power supply wiring arrangement:

- Meets the AS 1670.1:2004 requirement for detector supplies.
- Meets the AS 1670.1:2004 requirements for supplies to warning devices and ancillary devices.

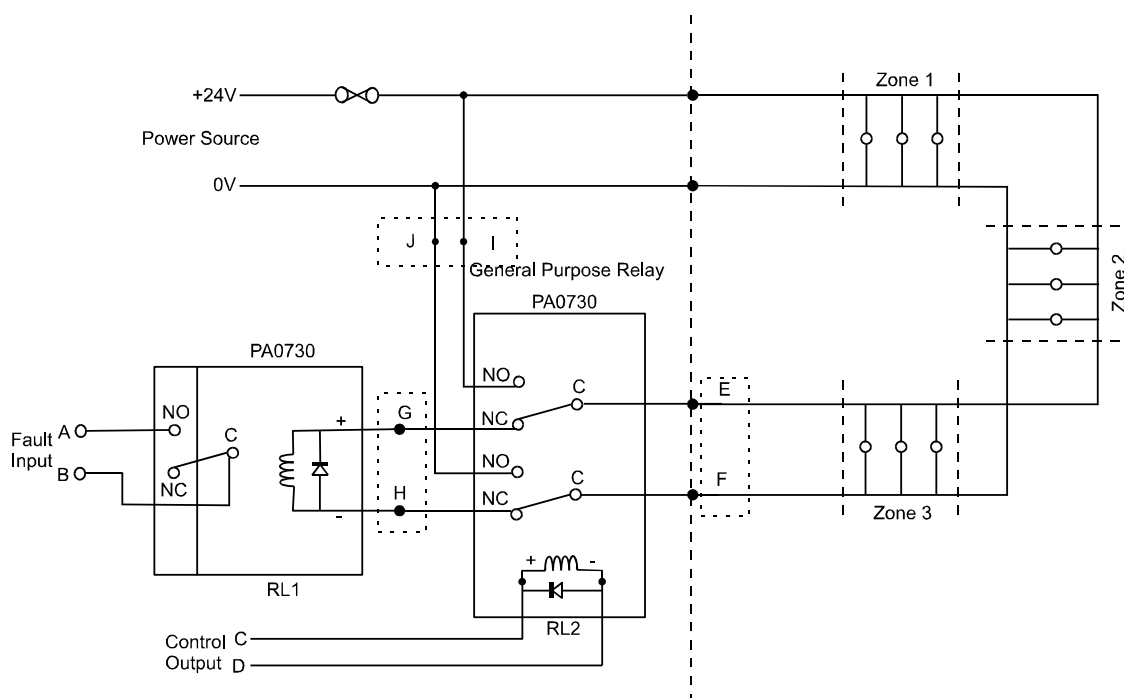

Figure 5.19 – General Supply Loop Arrangement for Multiple Devices in Multiple Zones

Power is normally supplied from one end of the loop and the continuity (no open or short circuit) of the loop is verified by an energised relay (RL1 in Figure 5-19) at the opposite end of the loop.

An open circuit in the loop will de-energise the relay (RL1) and signal a fault to the panel. Logic in the panel will energise the second relay (RL2) via the control output.

This arrangement will still provide power to all devices from both ends of the loop when there is a single open circuit fault in the power supply wiring. It will not provide power when there is a short circuit fault.

A fuse (or other current limiting device) must be used to protect against a short circuit. The fuse is supervised by the normally energised relay, RL1.

5.9.2 Example Application of Supply Loop Use

Some examples of how to supervise and control the loop power feed are:

- An SNM800 addressable control module.
- An 814RB addressable relay base and a fault detection input (e.g. MIM800).

These devices can be programmed and wired to points A, B, C, D as described in the next sections.

Note: Connection points E, F, G, H, I, and J are for connection to the contacts of an 814RB Relay Base when this is used in place of RL2 in Figure 5.19.

5.9.3 Using SNM800 to Control a Supply Loop Wiring

The power supply loop arrangement shown in Figure 5.19 can be wired to an SNM800 as shown in Figure 5.20. The SNM800 provides relay control and fault sensing.

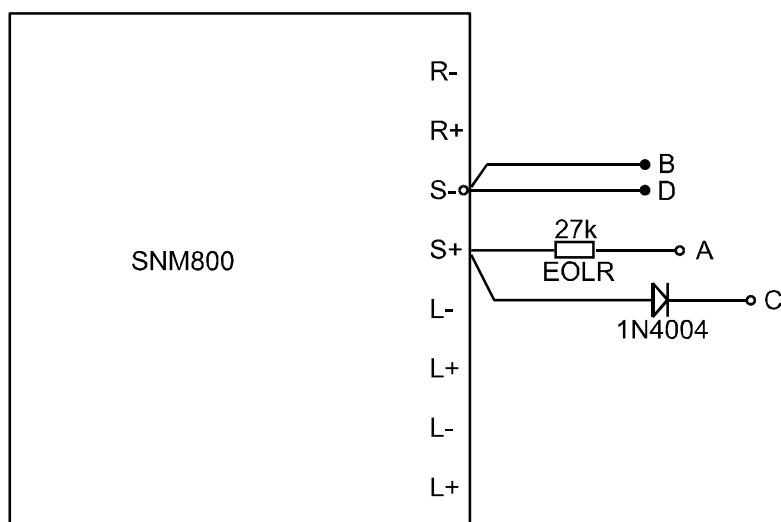

Figure 5.20 – Power Supply Loop Arrangement Using SNM800

Programming

Configure the SNM800 to select load and supply supervision, and map to a zone with an ACZ profile. Enter an output logic equation to operate this zone when it goes into fault. For example:

$$Z_{xx}OP = Z_{xx}F$$

Operation

When a fault occurs on the loop-power wiring, the zone will go into fault and RL2 will be energised.

If the ACZ zone profile specifies that faults will latch, the fault indication will need to be manually cleared by resetting the zone. This will remove the zone fault condition and de-energise RL2 (even if a fault condition is still present on the wiring). If the fault condition is still present on the wiring then a fault will be re-annunciated and RL2 will turn on again.

5.9.4 MIM800 with 814RB Relay Base to Control a Supply Loop Wiring

The power supply loop arrangement shown in Figure 5.19 can be wired to a MIM800 for supervision and an 814RB for control as shown in Figure 5.21. The 814RB has dual changeover relays (rated at 1A @ 30VDC) so these can replace RL2 in Figure 5.19.

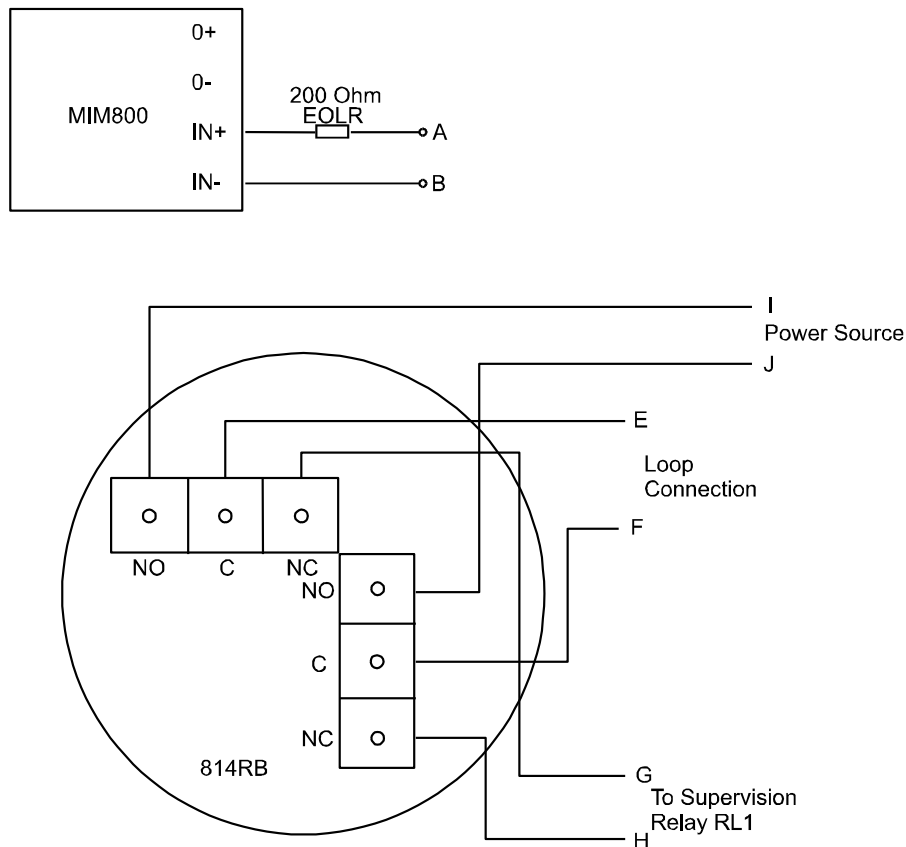

Figure 5.21 – Power Supply Loop Arrangement for MIM800 with an 814RB

Programming

The detector that plugs into the relay base must be programmed to have its base enabled and with output control by Logic.

Program the MIM800 with a profile having O/C Fault. Enter an output logic equation to turn the Relay Base on when the MIM800 is in fault. For example:

```
P1/pp/4OP = P1/mm/0FA ; detector controlling RB has address pp
                    ;the MIM800 has address mm
```

Operation

When a fault occurs on the loop-power wiring, the MIM800 point will go into fault and the relay base will be activated. Once the relay base has switched, the MIM800 will stay in fault, and effectively latch the relay base.

To clear the latched supply fault, the MIM800 point must be disabled. This will mask the input fault and cause the relay base to de-energise, restoring the power feed circuit to its normal mode. With the MIM800 point disabled, check its state on the LCD. If it still shows Fault, the supply fault is still present; enable the MIM800 to allow the power feed from both ends. If the point shows Normal while disabled, the supply fault is cleared; enable the MIM800 to restore normal operation.

Note that disabling the whole detector device plugged into the 814RB will de-energise the relay base irrespective of the fault condition. This will stop the alternate loop feed activating under a fault condition.

To avoid this, disable only the sub-points that need to be disabled, or make the functional base point non-disableable.

5.10 Intrinsically Safe Devices

5.10.1 General

The MX intrinsically safe (I.S.) devices listed below are suitable for use in classified explosive hazard areas. These devices may be connected to the MX1 addressable loop, but this must be carried out using an EXI800 MX I.S. loop Interface and an Intrinsically Safe Galvanic Isolator.

MX Intrinsically Safe Devices Compatible with MX1	
801CHEx	I.S. Combined Carbon Monoxide & Heat MX detector.
801PHEx	I.S. Combined Photoelectric & Heat MX detector.
801Hex	I.S. Heat MX detector.
801FEx	I.S. Flame Detector
IF800Ex	I.S. MX Single-Input Input Device
CP840Ex	I.S. MX Callpoint
S271i+	I.S. MX Flame Detector
FV421i	I.S. MX Flame Detector

5.10.2 Fire Detection Approvals

The FV421i and 801FEx have approval to AS 7240.10:2018, the standard for point flame detectors which is accepted under AS 1670.1:2018.

The other MX 801Ex series intrinsically safe detectors are similar, but not identical, to the earlier 814 series detectors used in normal areas. They comply with the EN54 European fire detection standards. Currently they have not been assessed to Australian Standards for fire detectors. Because of this they are also NOT currently Activefire listed. *It is the installation contractor's responsibility to ensure before sale and installation that use of these detectors will be accepted by the relevant authorities.*

Note that the 801Ex devices also have many major marine/shipping approvals such as Lloyds, ABS, DNV. Certificates are available from Johnson Controls.

5.10.3 Certification for Use in Explosive Atmospheres

In Australia, electrical installations in explosive gas areas are governed by the Electrical Safety Regulations 2002 (and amendments) which require compliance with the relevant

sections of AS/NZS 2381. The devices listed in the table above have both IECEx and ATEX intrinsically safe certification ("ia" classification, Gas Group IIC), and are therefore acceptable for use in Zone 0, Zone 1 and Zone 2 areas (ref. AS/ NZS 2381.1: 2005 section 2.6.2.2).

Copies of the following certificates are available from the Fireplace website:
<http://www.vigilant-fire.com.au>.

ATEX certificate for 801PHEX, 801CHEX, 801HEX, IF800EX, CP840EX: BAS01ATEX1394X

ATEX certificate for S271i+: Baseefa 02ATEX0257

ATEX certificate for System 800: Baseefa 03Y0265

ATEX certificate for FV421i: Baseefa 14ATEX0245X

IECEx certificate for FV421i: IECEx BAS 14.0113X

IECEx certificate for S271i+: IECEx BAS 05:0051

IECEx certificate for 801PHEX, 801CHEX, 801HEX, CP840EX, IF800EX: IECEx BAS 07.0063X

IECEx certificate for 801FEX: IECEx BAS 07.0075X

IECEx certificate for P&F KFD0-CS-Ex1.54: IECEx BAS 05.0004

5.10.4 Qualifications of Personnel

AS/NZS 2381.1: 2005 requires the design, construction, maintenance, testing and inspection of intrinsically safe systems to be carried out only by "competent persons" who have undertaken appropriate training for this type of system (refer AS/NZS 2381.1: 2005, 1.7).

5.10.5 Other Requirements

AS/NZS 2381.1 contains other mandatory requirements such as system documentation and system maintenance, inspection and testing (over and above that normally required for a fire alarm system). While it is primarily the responsibility of the installation owner to ensure that the relevant documentation is produced and testing and inspection is carried out, it will normally be up to the fire alarm installation contractor to ensure that the building owner is given the required information for the relevant parts of the fire alarm system.

5.10.6 Product Application and Design Information

A general outline only is provided below. Refer to the publication 17A-13-D, "System 800 - Intrinsically Safe MX Addressable Fire Detection System Product Application and Design Information" for detailed system design and installation information. This document is intended for use with European fire alarm systems, but the instructions are equally applicable to MX1 and must be adhered to for compliance with Ex area certification.

5.10.7 Connection to Addressable Loop

MX I.S. devices must be connected to a branch or spur from the main MX loop. This spur is isolated from the main loop by two devices:

- EXI800 – adapts the main loop voltage to match the actual isolator, and to allow the MX DIGITAL signal to pass through. This device also provides short circuit isolation, to prevent faults on the spur affecting the main loop.

- KFD0-CS-EX1.54 (or the 2-port KFD0-CS-EX2.54 - manufactured by Pepperl & Fuchs) – provides galvanic isolation and current limiting.

Figure 5.22 shows how the spur is connected to the main loop. The main MX loop can have up to eight I.S. spurs connected to it, each with its own EXI800 and KFD0 isolation device.

The I.S. certification places limits on the permissible cable capacitance and inductance of the spur wiring, depending on the hazardous gas that may be present. This will in turn limit the type and length of wiring that can be used for the spur. Refer to publication 17A-13-D for further details including recommended cable types and wiring diagrams.

Note: Despite the apparent (minor) discrepancy, the Pepperl and Fuchs galvanic isolator KFD0-CS-Ex1.54 ($P_o = 0.653W$) is matched to the 800Ex range of IS devices ($P_i=0.65W$) as evidenced by Baseefa System800 certificate 03Y0265.

AS 1670.1 requires that each spur be a single zone, since a single wiring fault can affect all the detectors on the spur. Also the I.S. certification specifies a combined maximum of 30 x 801PHEx, 801CHEx, 801HEx, IF800Ex and CP840Ex devices on a spur. Note that this is less than the limit of 40 devices on each spur permitted by AS 1670.1. A maximum of 10 S271i+ or 2 FV421i detectors are permitted on a spur.

The EXI800 and KFD0 isolation devices are normally located just outside the hazardous area, as shown in Figure 5.22.

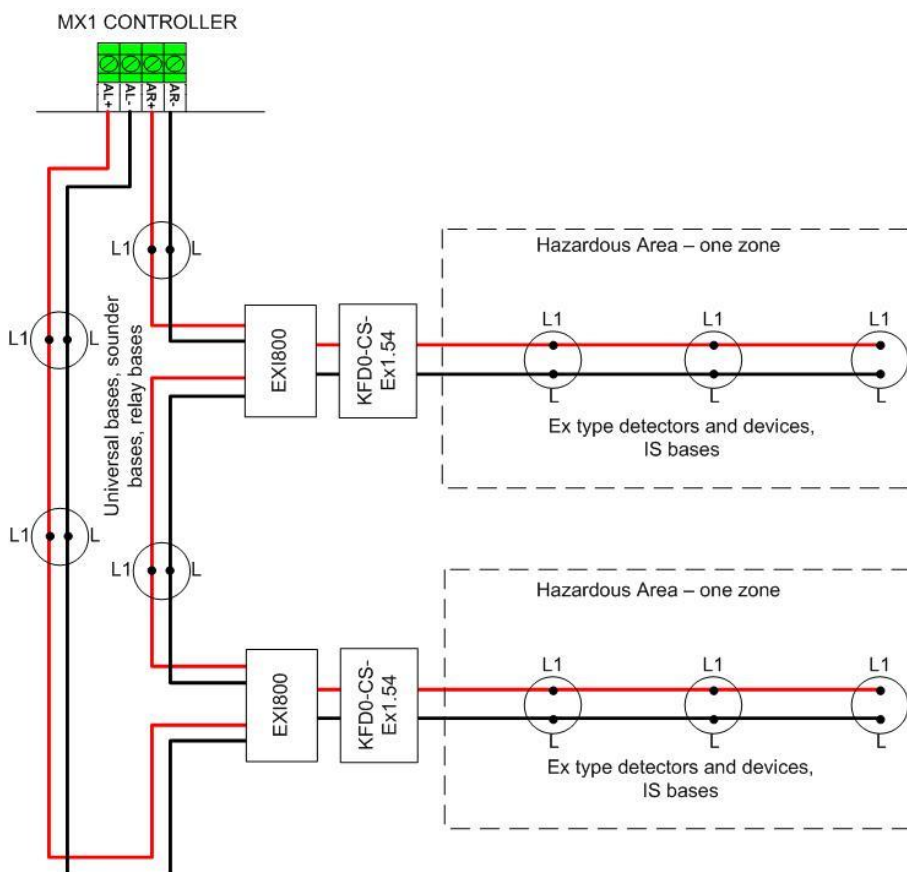

Figure 5.22 – Example of Intrinsically Safe Wiring Spurs

5.10.8 Detector Bases

The 800Ex detectors described in the following sections must be fitted to 5BEx bases. No I.S. rated isolator or sounder/relay bases are currently available.

5.10.9 801PHEX Photoelectric Smoke & Heat Detector

This I.S. detector has similar, but not identical photoelectric smoke detection characteristics to the 814PH detector, and is a separately listed detector type in SmartConfig. The default SmartConfig smoke detection profile for the 801PHEX is "Count Normal", with alternatives "Count High Sens" and "Count Low Sens" providing high and low sensitivity options. These algorithms are the only ones that must be used as the detector's EN54-approved status depends upon the use of them, and the detector's performance will be adversely affected if other algorithms are selected.

The "Count 57C" as provided should be used as the default detection algorithm for the heat detector within the 801PHEX as the detector's EN54-approved status also depends on this algorithm.

5.10.10 801CHEX Carbon Monoxide & Heat Detector

The 801CHEX has similar analogue CO and heat sensitivity characteristics to the 814CH. It is separately listed in SmartConfig with "Count Normal" as the default CO detection profile, and "Count High Sens" and "Count Low Sens" provided to give corresponding high and low sensitivity alternatives. "Count 57C" is provided as the default heat detection profile.

Because the CO and heat detection characteristics of the 801CHEX are essentially the same as those of the 814CH, any of the other profiles used with the 814CH may also be used for the 801CHEX.

Caution: The CO detector is not recommended for environmental conditions where an unusually high concentration of Hydrogen or Hydrocarbon vapour is present. Where there is likely to be long term exposure to a particular chemical agent, correct operation should be verified before fitting the detector.

5.10.11 801HEX Heat Detector

The 801HEX has similar analogue heat characteristics to the 814H and "Count 57" is provided in SmartConfig as the default heat detection profile. Because the detection characteristics of the 801HEX are essentially the same as those of the 814H, any of the profiles used with the 814H may also be used for the 801HEX.

5.10.12 801FEX Flame Detector

The 801FEX has fixed operation determined by SmartConfig and should be used with its default profile.

5.10.13 Remote LED & Functional Base Outputs

The 801PHEX, 801CHEX, 801HEX and 801FEX do not have output terminals for driving remote LEDs or functional bases. Older versions of SmartConfig may show output sub-points for these detectors but controlling these sub-points will have no effect for these devices. If these sub-points are present for these devices, they should be set to "Rem LED Not Used" and "Func Output Not Used", respectively.

5.10.14 IF800Ex Interface Module

This is an I.S. device for monitoring clean contacts such as ventilation status, extinguishing system controls, etc. It is housed in a moulded GRP box with 3 cable gland holes for cable entry and does not have an internal LED. The remote LED terminals on the internal module must not be used.

This device is the preferred method to connect standard (normally closed, hard-contact) devices to the IS Spur. Note that the devices connected to the IF800Ex input terminals must be "simple apparatus" only (see below), and therefore must NOT have indicators or contain electronics.

The IF800Ex does not supervise its input wiring, so the IF800Ex must be mounted immediately adjacent to the contacts being monitored, keeping the unsupervised input wiring very short.

Only "simple apparatus" may be connected to the input terminals of the IF800Ex, and there are restrictions on the cable parameters of the cable connected to these terminals. Refer to publication 17A-13-D for more information.

Note: Electrical inspectors have become very fussy about what constitutes "simple apparatus" and we strongly recommend any proposed device be pre-approved before you commit to using it.

Regardless of this, it is recommended that wiring to the input terminals be kept as short as possible to limit susceptibility to electromagnetic interference. Where possible the addressable wiring should be extended to the module rather than extending the module's input wiring.

The IF800Ex can be used with NO or NC contacts. The input sense is changed by selecting the appropriate input profile for the IF800Ex in SmartConfig. The default profile is "Normally open, interrupt on closure".

5.10.15 CP840Ex Manual Call Point

To provide fast MCP operation, interrupt mode is enabled in the default "CP840" SmartConfig profile.

All input wiring is internal to the CP840Ex, and no EOL is required.

The internal LED is visible from the front. The default settings in SmartConfig are for this LED to light on alarm and flash when the CP840Ex is polled.

5.10.16 S271i+ Flame Detector

This is an I.S. addressable version of the S200 triple waveband infrared flame detector. It is being replaced by the FV421i.

It is housed in a robust stainless steel enclosure with a clear sapphire window in the front. There are two 20mm gland holes for cable entry.

The analogue values returned by the S271i+ are based on predefined ranges for specific conditions (window fault, pre-alarm, alarm, etc.). The S271i+ profile in SmartConfig is based on these predefined ranges, and should not be adjusted, otherwise incorrect operation may result.

Refer to the S200+ Series Triple IR Flame Detector User Manual 120-415-400 for further information.

An installed S271i+ can be replaced with an FV421i Flame Detector. The *MX* loop operation is identical, however the loading and IS ratings of the FV421i are higher, so it will be necessary to check the *MX* loop loading and IS safety calculations when an S271i+ is replaced with an FV421i. Also the *MX1* configuration will need to have the device type changed.

5.10.17 FV421i Flame Detector

This is an I.S. addressable version of the FV400 FlameVision series triple waveband infrared flame detectors.

It is housed in a robust stainless steel enclosure with a clear sapphire window in the front. There are two 20mm gland holes for cable entry.

In SmartConfig the FV41Xf point type needs to be used for an FV421i. Although the *MX1* DP command will identify the FV421i, when the results are imported into SmartConfig the point is not created automatically – so it is necessary to manually enter the detector point (using the FV41Xf type).

The default profile assigned is **S271 Devices Int**, which enables interrupt for fast alarm signalling. A non-interrupt profile is available, if wanted.

The analogue values returned by the FV421i are based on predefined values for specific conditions (window fault, pre-alarm, alarm, etc.). The profiles in SmartConfig are based on these predefined ranges, and should not be adjusted, otherwise incorrect operation may result.

For further information on the FV421i refer to these documents:

- 120-515-204 FV421i Triple IR Flame Detector Fixing Instructions
- 120-515-203 FV421i Product Application and Design Information.

THIS PAGE INTENTIONALLY LEFT BLANK

6 *MX Loop Design*

6.1 Analogue Loop Configuration Selection

6.1.1 Lines and Loops

The interface between the *MX1* and its addressable devices requires two wires arranged in a loop.

MX1 has two ports (labelled AL, “left” and AR, “right”) which are designed to be connected to opposite ends of a loop of cable. Additional *MX* Loops can be supported by adding *MX* Loop Cards. The specifications for the in-built Loop and *MX* Loop Card are the same.

MX1 supports LOOP mode only. However, the *MX1* can also be used to connect to multiple lines in a star configuration as shown in Figure 6.2.

MX1 does not support dual line mode where the left and right ports are operated independently.

6.1.2 Loop Fault Tolerance

Fire alarm installation standards generally require that a line/loop fault condition cause limited disruption to the system's ability to detect and transmit alarms. The *MX1* achieves this in the following way:

The *MX1* has access to each device from both ends of the loop. The loop is normally powered from the “left” and monitored at the “right” terminals. Disappearance of 40V power at the “right” end, due to an open circuit on either the + or – wires, can be detected (causing a fault in the *MX1*) and corrected by switching the power feed onto the “right” terminals as well. The LOOP mode is therefore inherently fault tolerant to any single open circuit anywhere on the loop.

However, a short circuit on the loop will, in general, cause the *MX1* to lose communication with all devices, unless devices with short circuit isolators are used to localise the loss from a short circuit to a short stretch of cable.

The following devices provide short circuit isolation:

- 850xx detectors mounted in 4B-C bases
- MCP820 and MCP830 call points
- DDM800 universal fire & gas detector module
- QIO850, QMO850, QRM850 quad ancillary modules
- 4B-I and 5B-I isolator bases
- LIM800 Loop Isolator Module
- EXI800 IS Spur Interface Module
- P80SB, P80AVB, P81AVB Addressable Sounder Bases
- P80AVR, P80AVW Addressable Wall-Mount Sounder/Beacon

When designing fire alarm systems, the designer should be aware of any local authority requirements, as well as those of AS 1670.1 (see below).

6.1.3 AS 1670.1:2018 Design Requirements

Australian Standard AS 1670.1:2018 requires the analogue loop to comply with the following:

- A single short circuit shall not disable more than one zone. This means that if more than one zone of devices is to be connected to an *MX1* Loop, short circuit isolators must be fitted at the zone boundaries (and perhaps more often depending on the device types). This may require additional isolators, especially where devices without built-in isolators are used.
- An alarm zone shall be limited to no more than 2000 m² of contiguous floor area or 2000 m² of non-contiguous floor area with no entrances to adjacent areas being separated by more than 10m. The longest dimension shall not exceed 100m and shall be confined to one storey.
- A single open circuit shall register as a fault.
- Any condition, including short or open circuit, which prevents the transmission of an alarm shall register as a fault on all affected alarm zones.
- For further details of alarm zone limitations refer to AS 1670.1 s2.3, s2.6, s3.25 and s3.26.

6.2 Analogue Loop/Line Layout

6.2.1 Line Mode

MX1 is designed to run in Loop mode only. However, a star configuration can be used, described later in this chapter.

6.2.2 Loop Design with Short Circuit Isolators

There are two main reasons for using short circuit isolators on the analogue loop.

- When the *MX1* powers up a line/loop, it will have to power up only one section of the line/loop at a time, reducing the power surge from the *MX1* during start up.
- If the loop is shorted, then the *MX1* will lose communication with only those devices on the shorted section between two isolators. If every detector was an 850xx detector in a 4B-C base, or was mounted on an isolator base, then all detectors would remain functional in the event of a single short circuit.

To comply with AS 1670.1, isolators will need to be placed at least at every zone boundary on the loop.

Refer to Figure 6.1 for an example of loop wiring with Isolators.

Note the 850xx detector needs to be mounted in a 4B-C base for its in-built short circuit isolator to work.

Note each device with an SCI introduces a small resistance into the loop, which can add up if there are many. This increases the voltage drop and can lead to excessive voltage drop if the current is high.

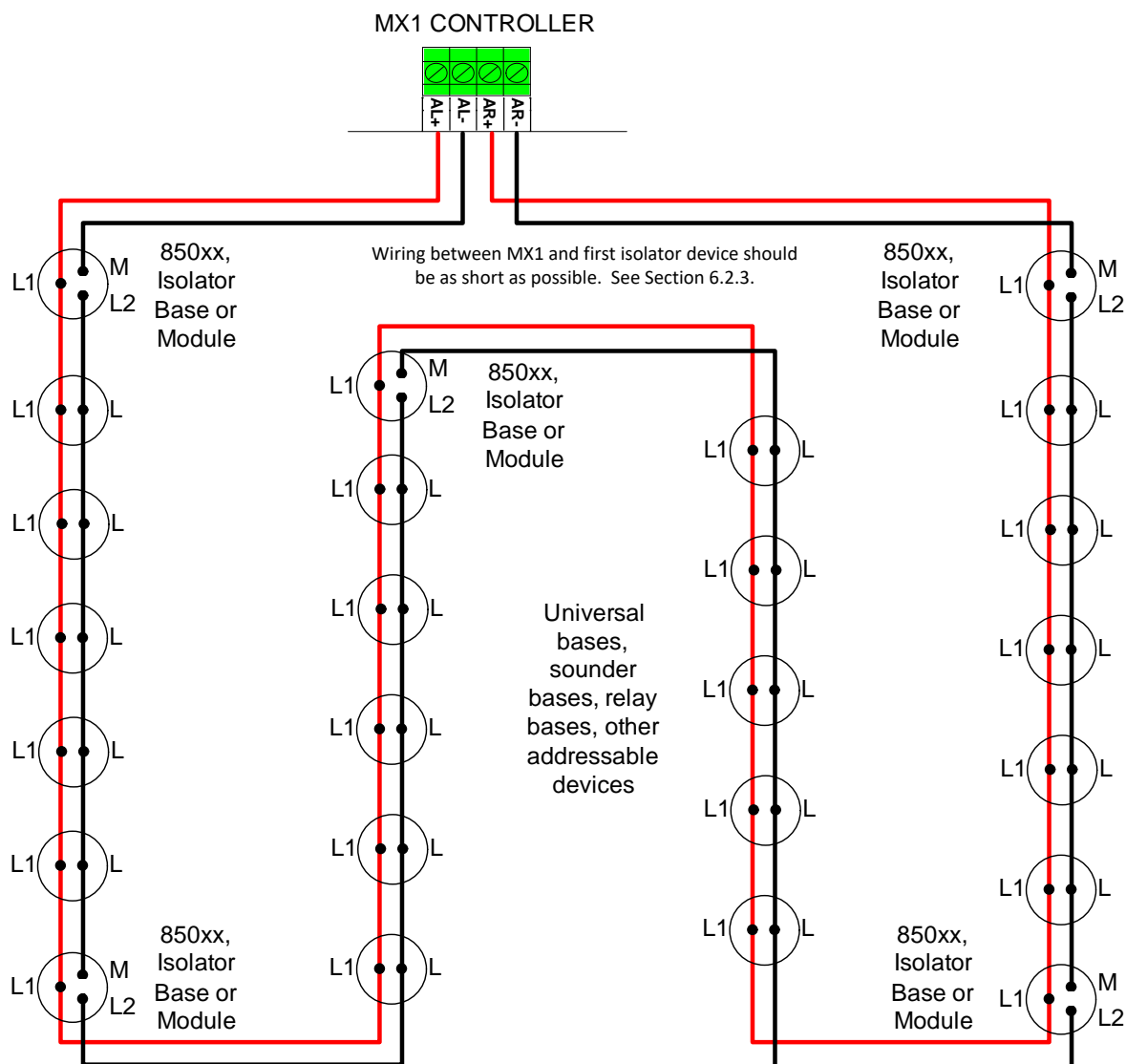

Figure 6.1 – MX Loop with Isolators

6.2.3 Design Notes

When using the older PA1011 MX1 Controller or MX Loop Cards Rev 1 or 2 it is necessary to install isolator bases (4B-I) or isolator modules (LIM800) between the MX loop terminals and the first and last devices on the loop as shown in Figure 6.1. This gives protection against short circuit faults in this part of the loop wiring. These isolators are not required with the latest PA1081 MX1 Controller and V1.4 Firmware, or MX Loop Cards Rev 3 onwards.

On earlier revision hardware, without these isolators, when a short circuit fault occurs, the MX1 will isolate the power feed to that end of the loop. However, at 30 second intervals, the MX1 will reconnect the power feed, to check if the fault has cleared. If the short circuit fault is still present, this will trip the power feed current limit in the MX1 and cause a short break in the power feed to the whole loop, until it isolates the faulty end of the loop again.

With isolators present the MX1 does not see the short circuit as the isolators are open each side of the short.

There is a limit to the number of devices between Isolators which depends on the type of devices being used. Use MX1COST to check the placement of isolators. The sum of IB units for each section must not exceed 100.

The M and L2 connections are interchangeable on the isolator bases.

6.2.4 Star Connection of Loop Wiring

It is not always necessary to connect addressable systems as loops, especially if an existing conventional detector system is being converted to addressable detectors. As the existing detector zone cables probably already terminate at the main panel, it is possible to connect these in a star connection to the *MX1* as shown in Figure 6.2.

The isolators may be either LIM800 modules or isolator bases (with or without a detector fitted).

The *MX1* AL and AR terminals should be joined together as shown in Figure 6.2. The total length of cable connected to the *MX1* (all branches added together) should not exceed 2000m.

Because shorting the cable in one line will short out all the other lines connected to the *MX1*, it is recommended that Isolators be fitted at the start of each line and then be placed along each line, as required. The cabling from the *MX1* to the initial Isolators should be as short as possible. To comply with AS 1670.1 no more than one zone can be on each line.

Note: the Star Connection is not recommended for new installations. The loop configuration should be used, as it offers complete protection for a single open circuit, maximum protection from multiple open circuit faults, and, with Isolators, short circuit protection.

6.2.5 Spurs

Both the loop format and the star topography can have "spurs" attached. (Spurs on a spur, for the star topography.)

Any such spur should be connected to the loop or its parent spur via an isolator (e.g., use a LIM800). See Figure 6.2.

However, spurs with multiple detectors are not recommended for new installations as an open circuit on the spur will disconnect all detectors further away from the *MX1* than the open circuit, and a short circuit will disconnect all devices past the previous isolator.

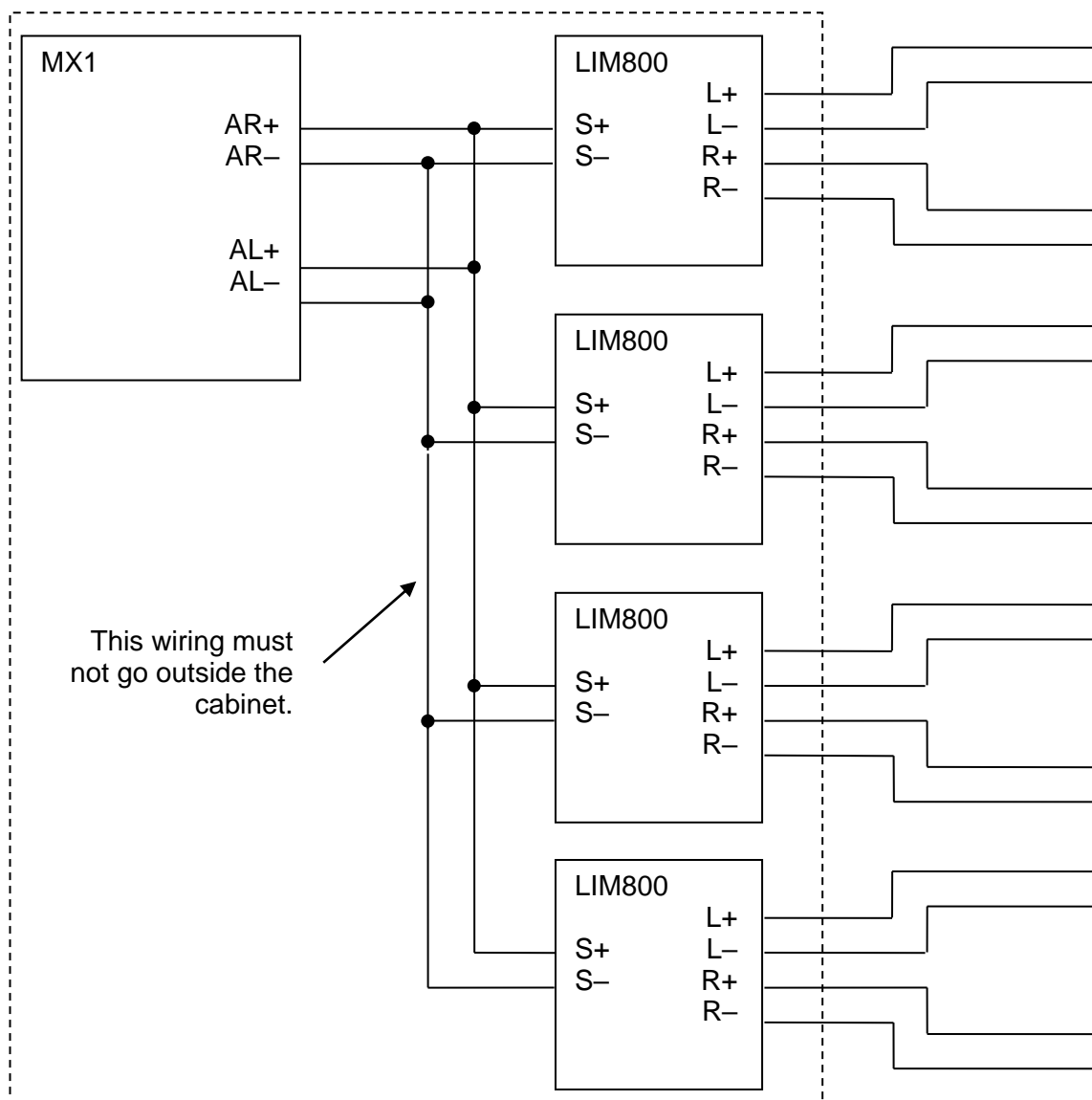

Figure 6.2 – Star Connection on MX1

6.3 Cable Selection Considerations

Selection of cable to implement the analogue loop requires specification of cable type, i.e., construction and choice of materials.

This is determined from consideration of

- Mechanical Requirements - for instance, does the application specification, or prevailing standards, call for cable that is fire rated, armoured, etc.
- Electrical Requirements - different cable construction/materials give different a.c. characteristics, noise immunity, etc.
- Cable Weight, i.e., gauge of wire used.
 - Standards - does the application, or prevailing standards, call for a minimum gauge (AS 1670.1 specifies a minimum of 0.75mm² gauge, for instance).
 - Electrical Resistance - What is the minimum gauge wire that can be used without exceeding the maximum voltage drop for the number of devices over the required loop length.

MX1COST can be used to check the resistance and a.c. characteristics of the cable to be used in the MX Loop.

6.3.1 Noise Considerations

Although the *MX* Loop has been designed for minimum electrical interference, it is still capable of both picking up and generating electrical interference. The longer the loop, the greater the scope for potential problems.

Each installation must be considered on its own merits, taking into account possible noise sources along the loop's proposed route. Normal engineering practice applies, such as keeping the *MX* loop wiring separate from other wiring, especially power cables, speaker cables, leaky coaxial cable and noise sensitive cables for audio or telephone systems.

In extreme cases it may be necessary to use screened cable for the analogue loop, with the screen connected to earth only at the *MX1*.

In general, physical separation between noisy cables and sensitive cables is more effective and reliable than screening.

6.4 Loop Calculation

A calculation must be conducted for each *MX* Loop to check that the quantity of devices present does not exceed various design limits (see Section 6.5).

For speed and accuracy, use of *MX1COST* is strongly recommended. This has the advantage of also doing battery requirements calculations, and producing summary reports for inclusion with commissioning documentation.

However, for straightforward systems (e.g., no IS devices, sounders and loads operate only in alarm), the loop calculation can be done manually, by filling in the following tables. Refer to section 6.6 if IS detectors/modules are present.

6.4.1 Manual Calculation

Use Table 6.1 and 6.2 for each separate loop. Enter the quantity of each device type and base on the loop in the Number column. Note there are separate entries for sounder/relay bases with 850 detectors to allow for the extra current taken when the base is activated. Multiply this by the corresponding NAL, AL and AC values for each device or base and put the results in the totals columns at right. Add up the NAL, AL and AC Total columns to produce the loop total currents.

The total loop battery loads are the currents drawn from the battery by the 40V loop supply to meet the loop current requirements. These values are used in the Battery capacity calculation in Chapter 9.

Table 6.1 – Addressable Device Currents

Device	Description	Number	NAL mA	AL mA	AC Units	NAL Total	AL Total	AC Total
850PH	Photo/Heat Detector		0.33	0.33	1			
850P	Photo Detector		0.33	0.33	1			
850H	Heat Detector		0.29	0.29	1			
850PC	Photo/Heat/CO Detector		0.37	0.37	1			
801F	Flame Detector		0.3	0.3	1			
814PH	Photo/Heat Detector		0.275	0.275	1			
814P	Photo Detector		0.275	0.275	1			
814H	Heat Detector		0.250	0.250	1			
814CH	CO/Heat Detector		0.275	0.275	1			
814I	Ionisation Detector		0.330	0.330	1			
CP820/CP830	Call point		0.275	0.275	1			
MCP820/MCP830	Call point		0.28	0.28	1			
CIM800	Contact Input Module		0.275	0.275	1			
DIM800	Detector Interface Module		0.280	0.280	1			
MIM800	Monitored Input Module (NO)		0.275	0.275	1			
MIM801	Monitored Input Module (NC)		0.275	0.275	1			
RIM800	Relay Interface Module		0.285	0.285	1			
SNM800	Sounder Notification Module		0.450	0.450	1			
SIO800	Single Input/Output		0.275	0.275	1			
MIO800	Multi Input/Output		0.480	0.480	1.2			
VIO800	VESDA Input/Output		0.480	0.480	1.2			
LPS800	Loop Powered Sounder Driver		0.450	*1	1.5			
SAB801	Addressable Beacon		0.250	3.25	1			
SAM800	Sounder Addressable Module		0.250	0.250	1			
VLC800MX	LaserCompact Unit		0.300	0.30	2			
FV411f / FV412f / FV413f	Flame Detector		3.25	3.25	2			
S271f+	Flame Detector		0.5	0.5	2			
QIO850	Quad Input/Output		0.575	0.575	1			
QMO850	Quad Monitored Output		1.175	1.175	1			
QRM850	Quad Relay Output		0.575	0.575	1			
DDM800 Loop Powered	Dual Detector Module (Loop Powered)		16	52	5			
DDM800 External Powered	Dual Detector Module (External Powered)		1.25	1.25	5			
P80AVB	Addressable Sounder/ Beacon Base		0.48	4.3 [^] 9.2 20				

P81AVB	Addressable Sounder/ Beacon Base		0.50	4.3^ 13.5 37.3				
P80SB	Addressable Sounder Base		0.35	2.4^ 4.3				
P80AVR	Addressable Wall-Mount Sounder Beacon		0.48	8.5^ 13 21				
P80AVW	Addressable Wall-Mount Sounder Beacon		0.48	8.5^ 13 21				
Device LEDs	Note: LED current for devices in alarm	-		30			30	
Total Addresses			Total Device Loads					

Note *1: LPS800 Alarm Current = greater of 12mA or load current +4mA per LPS800.

Table 6.2 – Functional Base & Module Currents

Base	Description	Number	NAL mA	AL mA	AC Units	NAL Total	AL Total	AC Total
4B-I	MX 4" Isolator Base		0.08	0.08	0.2			
5BI	MX 5" Isolator Base		0.08	0.08	0.2			
LIM800	Isolator module		0.16	0.16	0.1			
Allowance for a short circuit between IBs						7.00	7.00	
80DSB	MX Sounder Base		0.9	2.1^ 3.9				
802SB	MX Sounder (Loud) with 850 Detector		0.20	9.80	0.5			
802SB	MX Sounder (Quiet) with 850 Detector		0.20	4.20	0.5			
901SB	MX Sounder Base with 850 Detector		0.20	3.2	0.5			
814RB	MX Relay Base with 850 Detector		0.05	3.05	0.3			
802SB	MX Sounder Base (Loud)		0.20	6.80	0.5			
802SB	MX Sounder Base (Quiet)		0.20	1.20	0.5			
901SB	MX Sounder Base		0.20	0.2	0.5			
814RB	MX Relay Base		0.05	0.05	0.3			
Total Base Loads								

Add the Total Device Loads and Base Loads to produce:

Total Loop Loads

--	--	--

Multiply the NAL and AL total loop loads by 2 to produce:

Total Loop Battery Loads

--	--

^ In Tables 6.1 and 6.2 the three AL figures for sounder/beacons are at: High Volume No Flash; Low Volume Low Intensity 0.5Hz; High Volume, High Intensity 1Hz respectively. The two AL current figures for sounder bases are at: Low Volume, High Volume, respectively. The current shown for VADs is an average assuming equal distribution of the VADs around the loop. If the distribution is not equal, then a more accurate calculation using the position of the VADs and their power consumption will be needed.

6.4.2 Loop Isolator Limitations

When loop isolators are used, the number of devices that can be connected to the loop between each pair of isolators is limited. The sum of the IB ratings must not exceed 100.

Here are some examples of acceptable quantities of devices between isolators:

- 1 0-40 detectors + 0-10 Relay/Sounder Bases + 0-5 SNM800/RIM800
- 2 0-40 detectors + 0-20 Relay/Sounder Bases
- 3 0-40 detectors + 0-10 SNM800s/RIM800s

There is no need to do specific IB calculations if you are using isolators and your situation matches any of these examples. If necessary, you can add extra isolators to break up heavily loaded sections into smaller sections.

If you have a complicated loop structure, then MX1COST should be used to check that the loop loading is within acceptable limits.

Note that adding many devices containing an isolator to the loop will reduce the loop length or loading available, as there is a 0.25 ohm resistance for each isolator.

6.5 Loop Limits

6.5.1 DC Load

The maximum current available from the MX Loop Driver is 1000mA. Therefore for each loop the NAL Total Loop Load and AL Total Loop Load must each be less than 1000mA.

A maximum voltage drop of 17V is allowed on the cable from the MX1 to the most distant device. This applies both where the cable is driven from the “left” end only, and from the “right” end only. This is calculated as:

$$\text{VoltDrop} = (0.04 \times 0.75 \times \text{LoopLength(m)} / \text{CableSize (sqmm)} + 0.25 \times \text{NumberOfIBs}) \times \text{AL}$$

where AL is the AL Total Loop Load before it is converted into a battery load, and NumberOfIBs is the number of isolators (850xx detectors in 4B-C bases, MCP820/830 call points, 4B-I/5BI bases, DDM800, Quad I/O modules, LIM800, and EXI800) around the loop.

This voltage drop must be 17V or less.

6.5.2 AC Load

All common types of wiring with a total length of up to 2000m may be used. The total a.c. units for the loop is calculated:

$$\text{ACUnits} = \text{MXDeviceACUnits} + \text{LoopLength(m)} \times 0.1$$

where MXDeviceACUnits is the AC Total Loop Load from the above table.

If one or more IS spurs are part of the system then the AC loading of each spur must be included. Refer Section 6.6.

The ACUnits result must be 450 or less, otherwise unreliable polling of devices on the loop may occur.

6.5.3 On-board and Loop Card Loop Performance Limits

If you are using any SIO800, MIO800, 850PC or AZM800 devices on the *MX1* on-board loop (i.e., loop 1) the maximum number of devices allowed on this loop may be reduced to as low as 220, depending on the number of these devices present.

If you are using any DDM800, QIO850 or QMO850 devices on the *MX1* on-board loop (i.e., loop 1) the maximum number of devices allowed on this loop may be reduced to as low as 107, depending on the number of these devices present.

If you are using any DDM800, QIO850 or QMO850 devices on the *MX1* loop cards (i.e., loops 2 through 8) the maximum number of devices allowed on this loop may be reduced to as low as 125, depending on the number of these devices present.

These limits are to ensure detectors and devices are polled at an appropriate rate.

MX1COST and SmartConfig will display a warning message if the maximum number of allowed devices is exceeded.

Note that the DDM800 has DC and AC loading characteristics that limit its numbers even further.

6.6 Intrinsically Safe Spurs

A range of Intrinsically Safe *MX* devices can be connected to the *MX* loop via the EXI800 interface and a galvanic isolator. Refer to Section 5.10. However, there are strict rules as to the quantity of devices that may be connected and how these affect the overall *MX* Loop design.

The document 17A-02-ISLOOP, describes the rules and calculations necessary for the design of an IS spur attached to the *MX* Loop.

Each IS spur must be calculated separately using the MX1CAL (SF0332) tool (use Issue 1.2 onwards to support FV421i). Enter the required IS devices and cable type and length for each spur on each *MX* loop.

Each IS spur has a DC load limit of 30 DC units. Check the **DC Load from Loop (ma)** value shown in MX1CAL has not turned red (exceeds 30). If it has reduce the number of devices on the spur.

Each IS spur has a limit of 74 IS Units, reducing for each extra spur on the same *MX* loop. Check the **IS Units** value for each spur has not turned red. If it has, then the number of devices will need to be reduced (or the number of IS spurs on the *MX* loop reduced). Note that moving some IS devices to a new spur will not always fix the problem, as this will increase the number of spurs and thus decrease the maximum IS units per spur.

Add the **Total DC load of IS spurs** for the loop to the DC current calculated for the other *MX* devices on the loop. This must not exceed 1A for each loop.

Add the **Total AC Load of IS spurs** for each *MX* loop to the ACUnits value calculated for the other *MX* devices on the loop. This total must not be more than 450.

Add the **Total device Addresses** for each *MX* loop to the number of other *MX* devices on the loop. This total must not be more than 250.

We recommend you discuss any IS applications with Johnson Controls Technical Support in advance to avoid potential problems.

THIS PAGE INTENTIONALLY LEFT BLANK

7 Alarm Devices

7.1 Introduction

7.1.1 Alarm Device Types

A fire alarm system will almost always require alarm devices to be included to alert the occupants of the building to a fire alarm situation and prompt them to leave the premises.

MX1 supports a range of alarm devices including:

- T-Gen 60 and T-Gen 120 tone and speech generators (T-Gen2) with 100V loud speakers,
- 24V-powered sounders and VADs. Controlled from outputs on the *MX1* panel, LPS800, SNM800, or QMO850 addressable control modules,
- Bell Monitor Board,
- Sounder bases and VADs,
- AVI Mk2 – Audio Visual warning signs,
- QE20 EWS or QE90 EWIS system.

Not all options are compliant with AS 1670.1:2018.

The following sections describe installing, wiring and configuring these types of alarm devices.

7.1.2 *MX1* Logic Equations

MX1 contains an internal point called Alarm Devices, which is operated when the alarm devices are to sound. This can be used in output logic via the text substitution `$ALARM_DEVICES_ON`.

Generally, the recommended way to set an output point to be controlled by alarm devices is through setting the point's "O/P Control" field to `$ALARM_DEVICES_ON`. This enables SmartConfig's automatic generation of output logic to control the output and detect fault states. For example, if General Purpose Output 1 is set to `$ALARM_DEVICES_ON`, the following statements will be automatically generated in User Logic:

```
P241/4/0OP = $ALARM_DEVICES_ON  
$ALARM_DEVICES_ON_AUTO_FAULT = P241/4/0FA
```

The automatic fault state generation considers the point's ability to generate a fault. In the above example, should General Purpose Output 1 Supervision be set to supervise GP Out 1, fault states for General Purpose Output 1 will be detected through the supervision point rather than through the output point itself. Accordingly, SmartConfig will automatically generate the following User Logic to compensate:

```
P241/4/0OP = $ALARM_DEVICES_ON  
$ALARM_DEVICES_ON_AUTO_FAULT = P241/5/0FA
```

ANC1 and ANC3 have "O/P Control" set by default to `$ALARM_DEVICES_ON`. As well, most *MX* output devices will default to this setting when they are created or their functional output is enabled. To use an output for a different function will require the point's "O/P Control" setting to be changed to the required setting (e.g., Zone, Logic, etc.). To change an output point back to follow `$ALARM_DEVICES_ON`, select the drop-down box in the "O/P Control" field, and select `$ALARM_DEVICES_ON`.

Sometimes it is necessary to set the output point to follow more than just `$ALARM_DEVICES_ON`. In this case, the **Logic** option should be selected for "O/P Control" and a logic equation entered in the "Logic" field. For example:

\$ALARM_DEVICES_ON AND NOT \$SOUNDER_DELAY

Note that controlling outputs via “Logic” will not result in automatic fault state generation, and the user is required to manually enter this via the \$ALARM_DEVICES_FAULT equation in the “User Logic” page. For example, if ANC1 is set to follow alarm devices using the “Logic” option from above, the procedure would need to be:

Select **Logic** for ANC1 “O/P Control” in the Controller Points page.

In the “Logic” field to the right, enter:

\$ALARM_DEVICES_ON AND NOT \$SOUNDER_DELAY

In the “User Logic” page add to the \$ALARM_DEVICES_FAULT equation the ANC 1 relay supervision fault condition

\$ANC1_SUPERVSN_FAULT

7.1.3 100V Wiring

	<p>100V line output wiring is subject to the requirements of Australian Standard AS/ACIF S009:2006.</p> <p>Observe appropriate safety precautions and ensure that 100V lines are suitably isolated from low-voltage wiring.</p>
---	---

7.2 T- Gen2 (T-Gen 60 & T-Gen 120)

T-Gen2 can be used for installations that must meet AS4428.16 Grade 3 and Grade2. For Grade 2 installations, it is required that the power supply is separate and monitored, therefore it is recommended to use a separate T-Gen2 Grade 2 EWS (eg. FP1129 or BTO). Section 7.11 describes interfacing *MX1* with a multi-zone Grade 2 T-Gen2 system using RZDU and Section 8.21 describes using multiple relay outputs.

The following sections cover mounting the T-Gen2 Grade 3 equipment in and powered by the *MX1* panel.

7.2.1 Mounting

The gear plates in the *MX1* 8U and 15U cabinets have a mounting footprint for a single T-Gen2 tone generator. The T-Gen 60 mounts on one metal standoff and five plastic standoffs (supplied with the *MX1*). The metal standoff provides all the earthing required by the T-Gen 60. The T-Gen 120 mounts in the same place but uses four M4 x 10 screws and the Loop Card bracket mounting holes. The 15U gearplate also provides a mounting option on the right hand side fold for a single T-Gen 60 if required.

The T-Gen 60 mounted on a hinged 3U door with Grade 3 User Interface and integral PA microphone (FP1121) may be fitted in a 15U *MX1* cabinet (but not an 8U *MX1*). This has a pre-made 1.3 metre loom which plugs into the 6 way header on ANC1 in place of LM0319.

The hinged 3U door with Grade 3 User Interface (FP1122) may be fitted in a 15U *MX1* cabinet (but not an 8U cabinet). It has pre-made looms to connect it to the T-Gen2 on the gear plate.

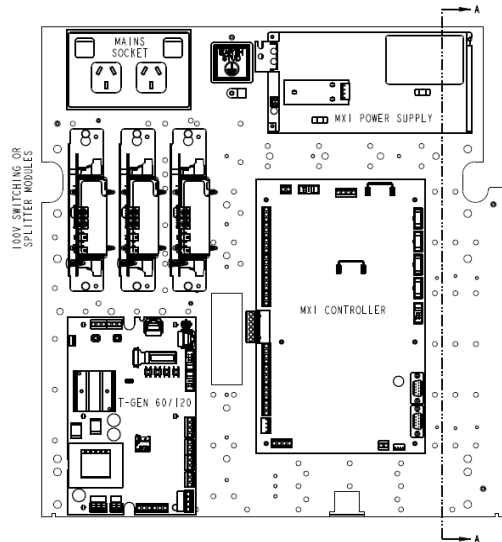

Figure 7.1 – Internal Layout of *MX1* 15U Cabinet Gearplate showing T-Gen 60

7.2.2 Wiring

The T-Gen2 is most easily controlled from the ANC 1 relay on the *MX1* Controller. Figure 7.2 shows the basic wiring for this. A pre-made loom LM0319 is supplied with each *MX1*, which provides all the necessary control and monitoring wiring for the connection to ANC 1. Note that the power wires on the LM0319 must not be used – rather, separate power wires are required as per Figure 7.2.

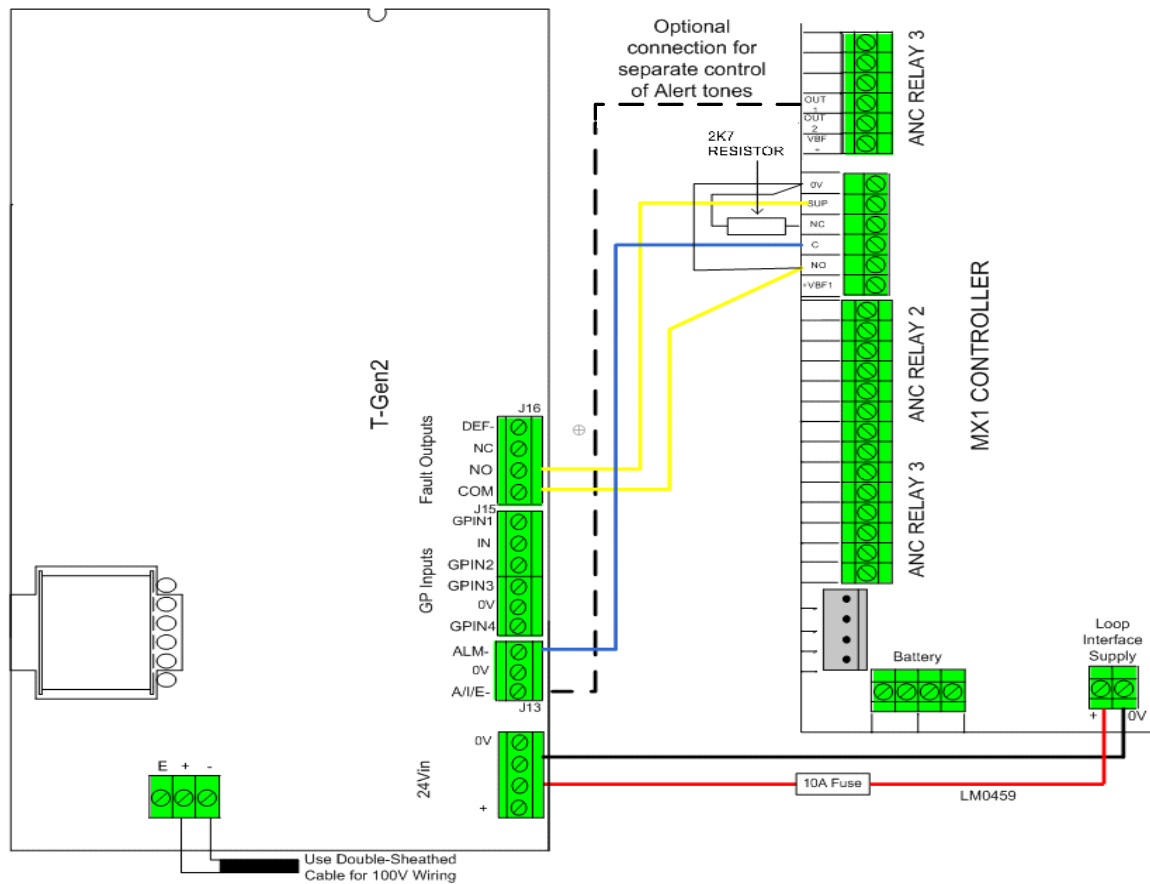

Figure 7.2 – T-Gen2 Wiring Details – Grade 3

In this arrangement, all the loom wiring is supervised, and the Fault output from the T-Gen2 is transferred to the MX1 Controller via the ANC 1 supervision input.

The T-Gen2 can produce Alert and Evacuate tones. The transition from the Alert to the Evacuate tone can be arranged to be done automatically by the T-Gen2 after a predetermined delay, or it can be controlled by the MX1 panel.

If MX1 control of the Alert (or other) tone is required, then an additional connection between one of the MX1 Controller GP Outputs and the T-Gen2 A/I/E- input is required. This is shown as the dotted connection in Figure 7.2.

The T-Gen2 could be alternatively controlled by the MX1's ANC 2 relay, however all the wiring connecting to ANC 1 in Figure 7.2 will need to be shifted to the same terminals on ANC 2.

A T-Gen2 can be controlled by the MX1 ANC3 relay, using the wiring shown in Figure 7.3. ANC3 supervision is set to "ANC3".

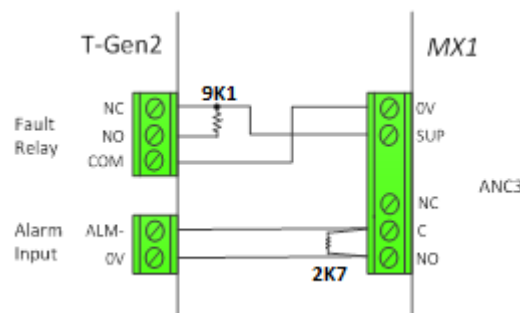

Figure 7.3 – T-Gen2 Wiring Using ANC3

If multiple T-Gen2s are required, then wire a separate PSU connection to the slave T-Gen2s and connect the T-Gen2s' 0V together. Connect the T-Gen2s together via QBus so the master can control the slaves. Additional T-Gen2s are configured as slaves. Refer LT0667 T-Gen2 Installation & Operating Instructions.

If an external PSU needs to be used, e.g. because the PSU rating of the MX1 is exceeded, then power the T-Gen2s from the separate 24V supply (eg, FP1139). Make sure the 0V connections between the T-Gen2s and the MX1 are maintained.

If the T-Gen2 is located in a separate cabinet, a longer loom is required. A suitable option may be LM0401, which is in essence a 1.3m long version of LM0319.

The FP1117 100V Switching module mounts in a Loop Card bracket position. It is wired to the T-Gen2 via a QBus loom, providing control signals and power, and the T-Gen2 100V audio output is wired to the FP1117 to provide the audio signal.

The FP1118 100V Splitter module mounts in a Loop Card bracket position. It needs 24V power wired to it, plus the T-Gen2 100V audio output.

Refer to LT0667 T-Gen2 Installation & Operating Instructions, LT0668 T-Gen 100V Switching Module Installation Instructions, LT0671 T-Gen 100V Splitter Module Installation Instructions, and drawings 1982-71 sheets 134 and 135.

The FP1121 Grade 3 EWS UI Door (with T-Gen 60) and FP1122 Grade 3 EWS UI Door (w/o T-Gen 60) are wired as per LT0672 Grade 3 User Interface Installation Guide.

7.2.3 Configuration 1 – T-Gen2 Control of Alerting and Evacuation Tone

In this configuration the T-Gen2 is simply activated in response to the alarm devices being turned on by the MX1. The management of Alert and Evacuation tones is done by the T-Gen2. The MX1 default template and T-Gen2 default “AS4428” configuration will provide this operation – no Alert is generated, just Evacuation tone.

MX1 Settings in SmartConfig

In the “Controller Points” window, for the “Anc1 Supervision” point (ANC1S), select supervision mode as **Contact**.

Additionally, for the ANC1 Output select the O/P Control setting to be **\$ALARM_DEVICES_ON**.

7.2.4 Configuration 2 – MX1 Control of Alerting and Evacuation Tones

In this configuration, the MX1 has the ability to separately control the Alert (or other) tone and the Evacuation tone. This type of operation might be required in a residential situation such as a nursing home. Smoke detectors could cause the Alert tone to be sounded everywhere (and not generate a general alarm), whereas a heat detector or manual call point will cause the Evacuation tone to be sounded everywhere.

The T-Gen2 default “AS4428” configuration will produce this operation, so long as the AIE wiring as per Figure 7.2 is in place.

MX1 Settings in SmartConfig

Define a zone or zones for the heat sensors and MCPs which are to be brigade calling. Most templates will have a suitable profile called **Std Detection G1**.

Define a zone or zones for the smoke sensors which are to be local alerting only. These need to use a zone type profile that does not call the brigade, nor activate the alarm devices – such as **Alarm List Only Std Det G2**. The common status of these zones will be available in Zone Group 2.

- Map the heat sensor points and MCP points to the brigade calling zone(s).
- Map the smoke sensor points to the local alerting zone(s).

In the Menu, Profiles, Logic Substitutions window, add this entry:

New Name	Substituted text	Predefined Output Control	Comments
\$ALERT_ZONES_ONLY	ZG nnn AL(1)	Y	Zone group for local alerting zones

where nnn is the number of the zone group of the local zones (2 in this case).

On the **Controller** page, for the GP Output that controls the A/I/E- T-Gen2 input, set that GP Output’s “O/P Control” to \$ALERT_ZONES_ONLY.

ANC1 will remain as the Evacuation tone output control and provide the fault monitoring of the T-Gen2.

7.3 T- GEN 50 (OBSOLETE – REPLACED BY T-GEN2)

7.3.1 Mounting

The gear plate in the *MX1* 8U and 15U cabinets has a mounting footprint for a single T-GEN 50 tone generator. The T-GEN 50 mounts on one metal standoff and five plastic standoffs (supplied with the *MX1*). The metal standoff provides all the earthing required by the T-GEN 50.

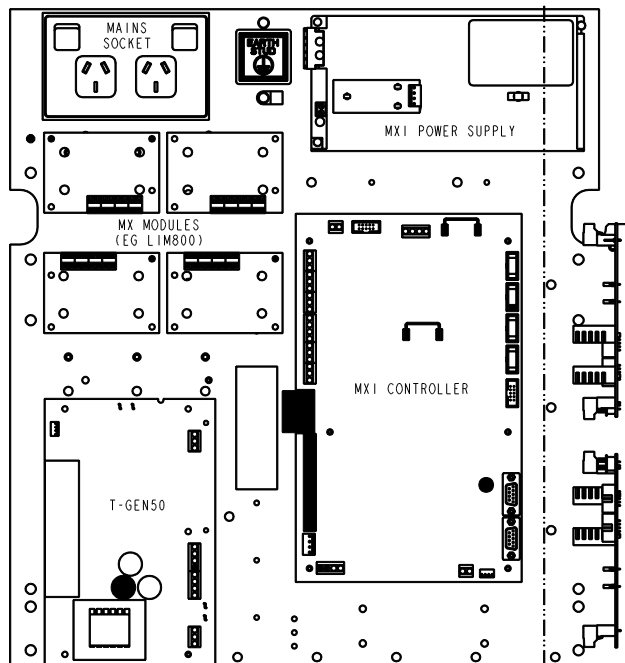

Figure 7.4 – Internal Layout of *MX1* 15U Cabinet Gearplate showing T-GEN 50

7.3.2 Wiring

The T-GEN 50 is most easily controlled from the ANC 1 relay on the *MX1* Controller. Figure 7.5 shows the basic wiring for this. A pre-made loom LM0319 is supplied with each *MX1*, which provides all the necessary wiring for the connection to ANC 1.

In this arrangement, all the loom wiring is supervised, and the Fault output from the T-GEN 50 is transferred to the *MX1* Controller via the ANC 1 supervision input.

The T-GEN 50 can produce Alert and Evacuate tones. The transition from the Alert to the Evacuate tone can be arranged to be done automatically by the T-GEN 50 after a predetermined delay, or it can be controlled by the *MX1* panel.

If *MX1* control of the Alert and Evacuate tones is required, then an additional connection between one of the *MX1* Controller GP Outputs and the T-GEN 50 A/I/E- input is required. This is shown as the dotted connection in Figure 7.5.

The T-GEN 50 could be alternatively controlled by the *MX1*'s ANC 2 relay, however all the wiring connecting to ANC 1 in Figure 7.5 will need to be shifted to the same terminals on ANC 2.

If multiple T-GEN 50s are required, then wire a separate +VBF or fused output to the slave T-GEN 50 (unless the combined load current is less the fuse rating of 3A), join the SIG terminals of the T-GENs together, and wire the Fault relays of each T-GEN in series. Additional T-GENs are configured as slaves.

MX1 Settings in SmartConfig

In the “Controller Points” window, for the “Anc1 Supervision” point (ANC1S), select supervision mode as **Contact**.

Additionally, for the ANC1 Output select the O/P Control setting to be **\$ALARM_DEVICES_ON**.

7.3.4 Configuration 2 – MX1 Control of Alerting and Evacuation Tones

In this configuration, the MX1 has full control over when the transition from Alert to Evacuate tone occurs. This type of operation might be required in a residential situation such as a nursing home. Smoke detectors could cause the Alert tone to be sounded everywhere (and not generate a general alarm), whereas a heat detector or manual call point will cause the Evacuation tone to be sounded everywhere.

T-GEN 50 Settings

- SW1-SW3 – all set ON to select Alert tone only, by default
- SW4 (Mon) – ON, to enable Alarm input supervision
- SW5 (Lat) – OFF to not latch alarms
- SW6-SW7 – as required to select the type of tone required
- SW8 (Att) – OFF for no attenuation of the tone level
- LK7 fit to the Relay position – refer T-GEN 50 instructions
- LK1-LK6 as required

MX1 Settings in SmartConfig

Define a zone or zones for the heat sensors and MCPs which are to be brigade calling. Most templates will have a suitable profile called **Std Detection G1**.

Define a zone or zones for the smoke sensors which are to be local alerting only. These need to use a zone type profile that does not call the brigade, nor activate the alarm devices – such as **Alarm List Only Std Det G2**. The common status of these zones will be available in Zone Group 2.

- Map the heat sensor points and MCP points to the brigade calling zone(s).
- Map the smoke sensor points to the local alerting zone(s).

In the Menu, Profiles, Logic Substitutions window, add these entries:

New Name	Substituted text	Comments
\$ALERT_ZONES_ONLY	ZG nnn AL(1)	Zone group for local alerting zones
\$EVAC_TONE_SELECT	P241/4/0OP	GP Out 1 to T-GEN A/I/E-

where nnn is the number of the zone group of the local zones (2 in this case), and P241/4/0 is the point number for the output controlling the A/I/E – input of the T-GEN (GP Out 1).

Set ANC1 “O/P Control” to **Logic**. In the “Logic” field to the right, enter this equation:
\$ALERT_ZONES_ONLY

In the **User Logic** page, add an equation to force on the GP Output that controls the A/I/E-T-GEN 50 input:

$$\$EVAC_TONE_SELECT = \$ALARM_DEVICES_ON$$

Append or add \$ANC1_SUPERVSN_FAULT to the \$ALARM_DEVICES_FAULT equation:
\$ALARM_DEVICES_FAULT = \$ANC1_SUPERVSN_FAULT

Note: This programming will mean the Alert tone will be sounded if the Silence Alarm Devices function is used to silence the evacuation tone.

7.4 MINI-GEN

7.4.1 General

The Mini_Gen is not compliant with AS 4428.16, so in general cannot be used as part of the occupant warning system to AS 1670.1. This section is included for historical information.

7.4.2 Mounting

In the recommended gearplate positions, the 15U cabinet can accommodate three 24V Mini-Gen tone/speech generators, or two Mini-Gens if a T-GEN 50 is fitted. The 8U cabinet can accommodate two Mini-Gens if a T-GEN 50 is not fitted. These Mini-Gen positions can alternatively be used for ISO 8201 Strobe Drivers – see Section 7.5. The number of Mini-Gens that can be installed is also limited by the number of supervised wiring branches that can be supported (three), and the capacity of the mains power supply and batteries.

The first Mini-Gen should be mounted in the lower position (see Figure 7.6) using the supplied plastic standoffs, and earthed via an earth lead and M3 screw to the nearby M3 metal insert in the gearplate. Subsequent Mini-Gens each mount on four plastic standoffs and should be earthed via the first Mini-Gen as shown in Figure 7.6. Refer to drawings 1982-71, sheets 152 to 160 for the 8U gearplate mounting positions and 140, 141, 142, 143, 144, 148 and 149 for the 15U gearplate mounting positions.

7.4.3 Wiring

The Mini-Gens are best controlled from the Ancillary Relay 3 output (ANC3) for two reasons:

- The current rating of ANC1 or ANC2 relays is barely enough to handle a single Mini-Gen.
- Only the ANC3 relay supports supervision of multiple wiring branches.

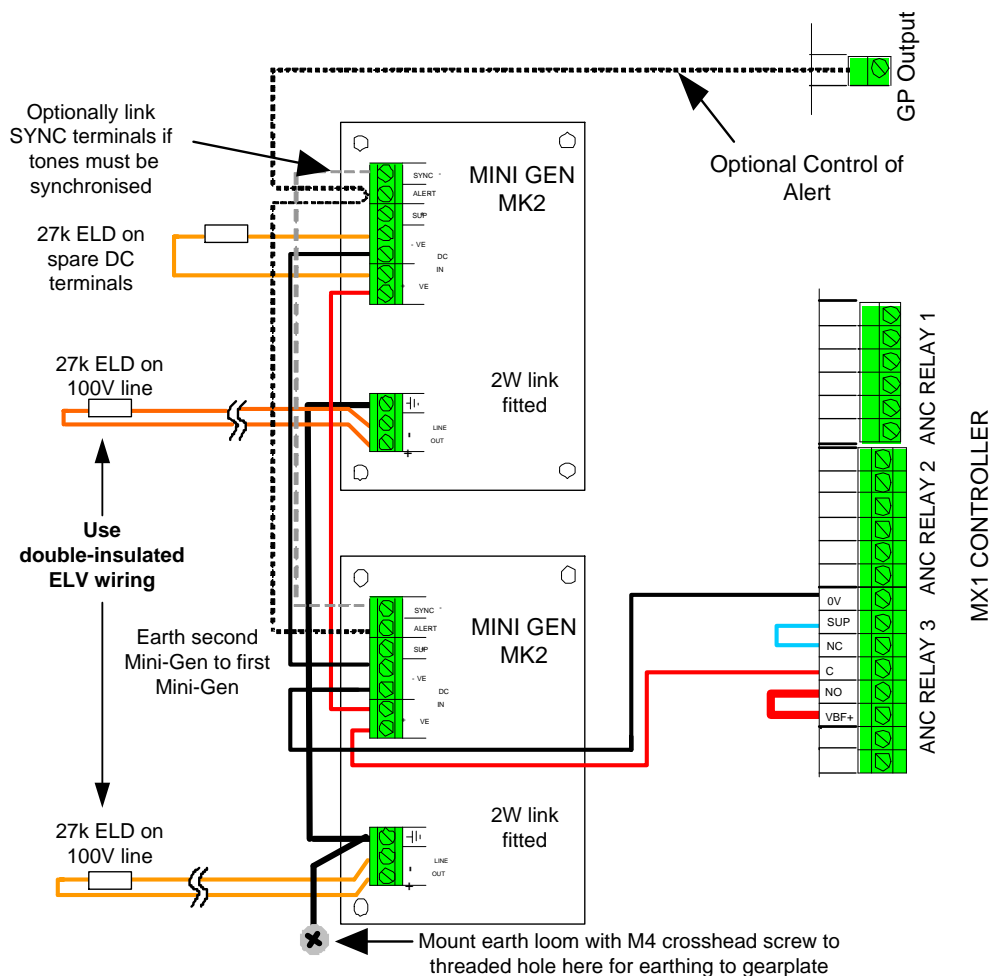

Figure 7.6 – Mini-Gen Mk2 Wiring Details

A 27kΩ ELD should be used on the 100V loudspeaker lines (use the ones supplied with the MX1). Do not use the 18kΩ and 9.1kΩ ELDs on the 100V line as they will overheat when the Mini-Gen is operating.

There can be up to a collective total of three branches of loudspeaker wiring connected to the Mini-Gens. If there are fewer than three branches, the unused 27kΩ ELDs must be connected across the unused DC IN terminals of the last Mini-Gen so that there are still three ELDs overall.

For the Mini-Gen Mk2, if synchronisation is required between multiple units, inter-wire the Synch terminals. If panel control of the Alert signal is required (e.g. for a different change-over time) then inter-wire the Alert- terminals and connect them to a suitable output on the MX1, e.g., one of the GP out terminals. This will need to be programmed – see below.

7.4.4 Configuration

Mini-Gen

All Mini-Gens must have their 2W supervision link fitted. Refer to the appropriate Mini-Gen Installation Instructions for details of the other link setting options for tone selection, change-over time, etc.

MX1 Settings in SmartConfig

If supervision is required, then in the “Controller Points” window, for “Anc3 Supervision” point (ANC3S), set the supervision mode to **ANC3**. Otherwise, set the supervision mode to “None”.

Also in the “Controller Points” window set the “O/P Control” setting for the ANC 3 point to **\$ALARM_DEVICES_ON**.

7.4.5 Configuration 2 – MX1 Control of Alerting and Evacuation Tones

In this configuration, the MX1 controls whether Alert or Evacuation tone is generated by the Mini-Gen.

Mini-Gen Settings

Links CDEFG on the Mini-Gen must be set up to allow the ALERT- input to produce Alert tone. Refer to the table in the Mini-Gen Installation Instructions (LT0364) for details on the available combinations.

MX1 Settings in SmartConfig

Zones for control of Alert and Evacuation must be defined in the MX1 configuration. Copy the zone definition details in the T-Gen2 example in section 7.2.4.

In the Logic Substitutions window of the User Logic Table, add these entries:

New Name	Substituted Text	Comments
\$ALERT_ZONES_ONLY	ZG nnn AL(1)	Zone group for local alerting zones
\$ALERT_TONE_SELECT	P241/4/0OP	GP Out 1 to Mini-Gen ALERT-

where nnn is the number of the zone group of the local zones, and P241/4/0 is the point number for the output controlling the ALERT- input of the Mini-Gen. (GP Out 1 in this example).

For the output controlling the Mini-Gen’s Alert input set the “O/P Control” setting to **Logic** and to the Logic cell add

\$ALERT_ZONES_ONLY AND NOT \$ALARM_DEVICES_ON

Control of Anc3 requires the “O/P Control” setting to be **Logic** and the logic cell to be **\$ALARM_DEVICES_ON OR \$ALERT_ZONES_ONLY**

Supervision of Ancillary Relay 3 is the same as in section 7.4.3.

7.5 ISO Strobes

7.5.1 General

The use of strobes as part of the occupant warning system is no longer permitted by AS 1670.1. VADs complying with AS 7240.23 must be used. Refer to Section 7.6. Information on using the ISO8201 Strobe Driver is included for historical reasons.

7.5.2 Mounting

The 8U gearplate has 2 positions for mounting either the PA1043 ISO 8201 Strobe Driver Module or Mini-Gen Tone Driver Modules – refer drawing 1982-71 sheet 153.

The 15U gearplate has 4 positions for mounting either the PA1043 ISO 8201 Strobe Driver Module or Mini-Gen Tone Driver Modules – refer drawing 1982-71 sheet 141.

Note these positions overlap with other modules (e.g., T-GEN 50), so may not always be available. The ISO Strobe Driver mounts on plastic PCB standoffs fitted from the front of the gearplate.

7.5.3 Wiring

The ISO Strobe Driver(s) is best controlled by the ANC 3 output as this supports the reverse polarity supervision utilised by the Strobe Driver and provides 3A of current.

As the MX1 Anc 3 output supports up to 3 branches of reverse polarity wiring, up to 3 Strobe Drivers and Mini-Gens can in fact be wired onto the same output (as long as the combined current does not exceed the 3A rating).

Use the 27kΩ ELD on each branch, or fit to the unused DC IN terminals on the last Strobe Driver (or Mini-Gen) so that there are 3 ELDs wired in total.

To synchronise the strobe flashing wire the SYNCH- terminals of the Strobe Drivers together.

Wiring of the Strobe Drivers is shown in Figure 7.7.

7.5.4 Configuration

Strobe Driver

The 2W switch on the Strobe Driver must be turned on when ANC 3 wiring is used. Refer to the Strobe Driver Installation Instructions (LT0383) for further details.

MX1 Settings in SmartConfig

By default ANC 3 is programmed to operate with the Alarm Devices, and in most cases this is suitable for driving the Strobe Driver. Supervision should be enabled – select **ANC 3** supervision for the ANC 3 supervision point in the Controller Points table.

The ANC 3 output point's "O/P Control" should be set to **\$ALARM_DEVICES_ON** to enable control of the output and mapping of a supervision fault to the Alarm Device fault status.

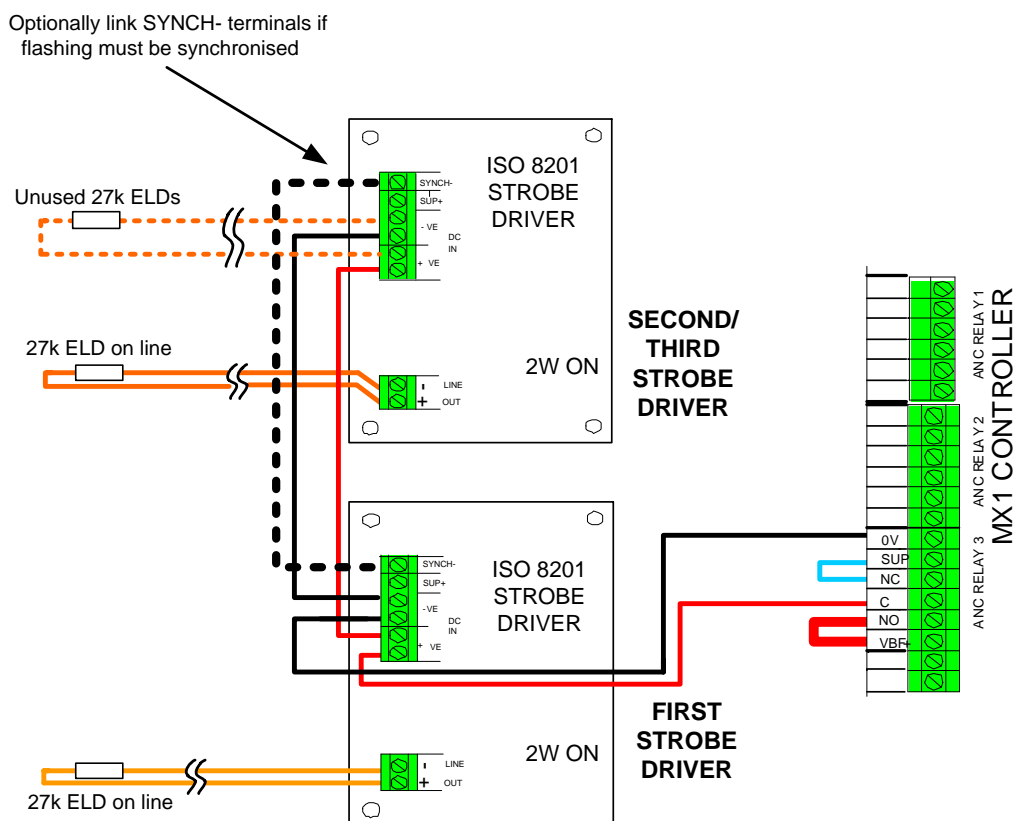

Figure 7.7 – ISO 8201 Strobe Driver Wiring Details

7.6 Sounders (AADs) and Beacons (VADs)

7.6.1 General

AS 1670.1 requires sounders (AADs) and beacons (VADs) complying with AS 7240.3 and AS 7240.23 respectively to be used as part of the occupant warning system.

The use of the Solista range of conventional AADs and VADs is recommended as they are approved to these standards and include other features needed by fire alarm systems.

7.6.2 Wiring

24V powered sounders (AADs), bells, beacons (VADs) and strobe lights can be controlled from the Ancillary Relay 3 output, if multiple branches or supervision are required. Loads of up to 5A can be controlled in this way, but note that the VBF+ outputs from the *MX1* Controller are fused at 3A. If supervision is required, then each device must have a series diode connected or incorporated as shown in Figure 7.8. A suitable diode for a load up to 1A is 1N4004 or 1N5404. Inductive loads such as bells must have suppression capacitors or diodes fitted as well.

For a single branch, the ELD value is 9.1kΩ. For two branches, each ELD is 18kΩ. For three branches, each ELD is 27kΩ. Suitable ELDs are supplied with the *MX1*.

Many strobe lights draw a large inrush current when first turned on. For this reason, strobe lights should be controlled from only the *MX1*'s Ancillary Relay 3, which has a higher current rating than the other ancillary relays.

The "Solista" range of AADs and VADs are well suited to this application, as they are AS 7240.3 / 23 approved (as appropriate), generate the T3 ISO 8201 signal, are synchronised on the same circuit, operate off a wide supply voltage range and include an in-built diode. Note though that the VADs draw an increased current as the supply voltage falls, so it is necessary to do load and voltage drop calculations with the VADs at the minimum voltage. These VADs are specified as 25mA at 24V, but at 18V they draw approximately 33mA.

For example. Twenty VADs are connected to a circuit, so the maximum current draw would be 660mA. If they are all at the end of 500m of 2.5mm² cable (14Ω/km), there will be a drop of 4.6V (0.66A x 14 x 0.5) in the cable. This means the minimum supply voltage from the panel needs to be at least 18 + 4.6 = 22.6V and the output needs to provide at least 0.66A.

7.6.3 Configuration

MX1 Settings in SmartConfig

If supervision is required, in the "Controller Points" window for "Ancillary Relay 3" set the supervision mode to **ANC 3**. Otherwise, set the supervision mode to **None**.

For the ANC 3 output point (or ANC 1 or 2 if being used) set the "O/P Control" field to **\$ALARM_DEVICES_ON**.

7.6.4 Using MX Modules

The LPS800, SNM800 and QMO850 *MX* Modules provide supervised switched outputs suitable for driving 24V powered bells, sounders, strobes, VADs or other annunciation devices. Details are covered in Sections 5.7.6, 5.7.10 and 5.7.11, respectively.

Where a common supply is used for multiple outputs (e.g., floors or areas > 2000m²), each output needs to be protected with a suitable fuse (rated just greater than the maximum load current) so that a short circuit does not affect more than one output.

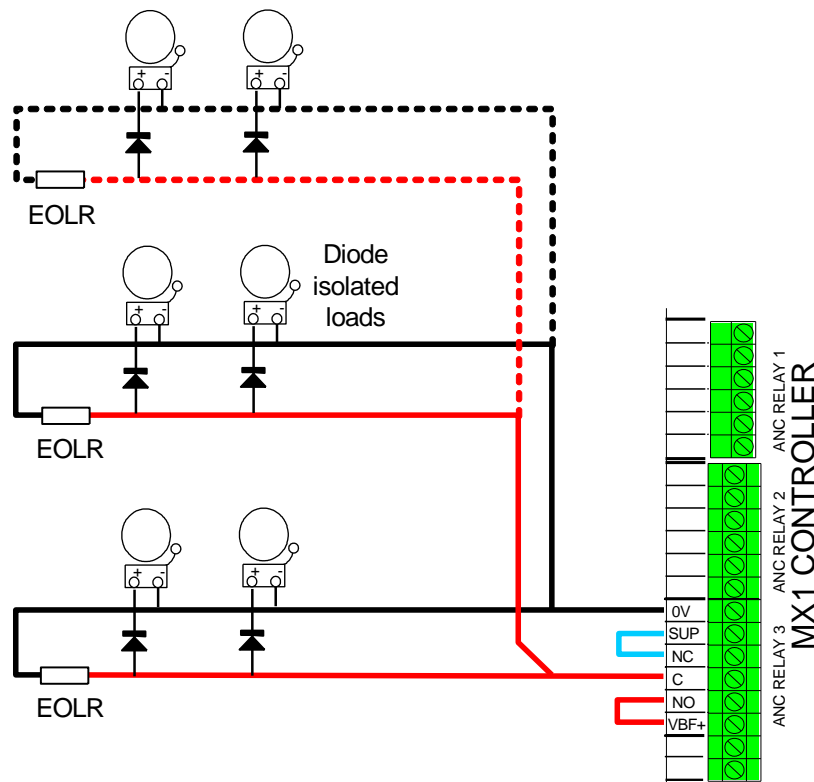

Figure 7.8 – AADs, VADs, Bells or other d.c. Sounder Wiring Details

7.7 Detector Sounder Bases

Sounder bases (80DSB, 802SB, 912SB) can be used with detectors (or SAB801 or SAM800) on the *MX1* detector loop to provide local alarm warning for alarms on an individual zone or parts of zones, e.g., residential units.

The *MX* Addressable Sounder Bases (P80SB), addressable sounder/beacon bases (P80AVB, P81AVB) and addressable wall-mount sounder/beacons (P80AVR, P80AVW) are all *MX* addressable devices in their own right and so can be used with or without a detector plugged in. Each device has its own address, so will reduce the number of *MX* detectors/modules that can be on the same loop.

The addressable sounder bases and VADs can also be used with the Alarm Delay Facility – refer to Section 8.25.

Wiring

The sounder bases (80DSB and older 802SB, 901SB, 912SB, 814SB) do not have a short circuit isolator and bypass the SCI in any 850 detector plugged in to the base, so should not be used as the first or last device of a zone if the zone wiring extends into another zone. Also these sounder bases do not synchronise the signal, so should not be used with temporal 3 if multiple sounders can be heard.

Make sure that the *MX* Loop loading calculation includes the maximum number of sounder bases that are present and turned on at the same time. *MX1COST* is able to do this and check the result.

Addressable Sounder/Beacons – Alarm Devices

In this example *MX* addressable sounder bases (P80SB) and/or addressable sounder/beacons (P80AVB, P81AVB, P80AVR, P80AVW) are used for the building evacuation system (Alarm Devices) – as per AS 1670.1:2018 Clause 3.22.1(b) (ii).

All these devices will need to be controlled by `$ALARM_DEVICES_ON` so that they all turn on together and are not delayed.

For the sounder sub-point a profile using the Temporal 3 tone (e.g. T3 High Vol) will need to be selected so the sound complies with ISO 8201.

A profile for beacon sub-points can be selected to give the desired flash rate and intensity.

Each sounder subpoint **O/P Control** setting should be set to `$ALARM_DEVICES_ON`.

Each beacon subpoint **O/P Control** can be set to `$ALARM_DEVICES_ON` if the beacon should turn on for Alarm Devices on, or **None** if the beacon is not required.

All addressable sounder bases/beacons on the same MX loop will be synchronised for the tone and flash, after the initial turn on cycle.

The addressable sounder/beacons include a built-in short-circuit isolator, so if wired as the last device in a zone/apartment/area they will provide short-circuit protection to the next zone/apartment/area.

Note, these devices can be used with or without an *MX* detector fitted. If a detector is not fitted to the base then the B-CAP blanking cap should be fitted to protect the sounder base wiring terminals.

Addressable Sounder Base – Local Alarm

In this example addressable sounder bases (P80SB) are used to provide local alarms on any smoke detector activation in an SOU or apartment, with heat sensor alarms creating a full alarm.

As the sounder bases can produce only one pre-selected tone, a separate system with a different tone will most likely be used for building evacuation. Thus the tone selected for the bases should be audibly different to the evacuation signal to avoid confusion.

The SOU/apartment/area should be configured as a unique zone and the 850PH detectors and the addressable sounder bases mapped to the zone. The zone should use the “Residential AU” profile, which has the zone output control set to **Alarm or Activate**.

The 850PH detector should be configured as follows:

- Map the detector as a whole to the zone (this included the heat and smoke sub-points).
- On the smoke sub-point change the Point type to **Smoke-Not Alarming** and un-tick the Latching checkbox. Set the profile and text as required.
- Configure the heat sub-point as required.
- Do not configure a functional output sub-point.
- Map the addressable sounder base (as a whole) to the same zone and select the required sounder sub-point profile (tone and volume).
- Change the **O/P Control** for the Sounder sub-point (1) to Zone, so that the Zone Alarm or Activate state turns the sounder on.

If any smoke alarms are triggered in the zone, all addressable sounder bases in the zone will turn on, and turn off when the smoke clears.

Note that any heat sensor alarm will also turn the sounder bases on, which may not be desired, as the building evacuation system will also be sounding.

In this case the **O/P Control** for the Sounder sub-point (1) should be set to Logic and a logic equation of the format

```
ZxOP . ^$ALARM_DEVICES_ON
```

Be entered so that Zone Operate (Alarm or Activate) turns the sounder on if the Alarm devices are not also activated.

Sounder Base Example Configuration – Local Annunciation of Smoke Alarm

In this example, an 850PH smoke and heat detector is fitted to an 80DSB sounder base in an apartment configured as Zone 10. The requirement is for a smoke sensor alarm to activate the sounder base but not the alarm devices nor the alarm routing, whereas activation of the heat sensor is to sound the alarm devices and activate the alarm routing. The smoke sensor and sounder base must return to normal automatically when the smoke clears. The detector LED must go out when smoke clears, but remain latched on for a heat alarm.

Zone 10 is configured to use the “Residential Au” zone profile, which has its output control set to **Alarm or Activate**. This profile will automatically control the sounder base for local annunciation of the smoke alarms, and the zone will indicate the alarm condition and activate the alarm routing and alarm devices for heat alarms.

The 850PH device is configured as follows:

- The detector as a whole is programmed to map to Zone 10 for the purposes of alarm and fault indication, and control of the functional base output which activates the sounder base.
- The heat sensor sub-point is automatically mapped to Zone 10 for alarm indication. It should have a point type of **Heat** (default) and be set to **latch** the alarm condition (default). Other parameters may set as desired.
- The smoke sensor sub-point is automatically mapped to Zone 10. It should have a point type of **Smoke Non Alarming** and be set to **not latch** the alarm condition. Other parameters may set as desired.
- The internal and remote LED indicator sub-points are set for **Pt Alarm/Active** (default) and to **Not Latch** (default). Other parameters may be set as desired.
- The functional base output sub-point must be set to **Func Output**, and its O/P Control must be set to **Zone**. It will automatically be controlled by Zone 10. Other parameters may be set as desired.

If the smoke sensor is triggered, the detector LED turns on and “Active Input” is signalled to Zone 10. In response, Zone 10 turns on the detector’s functional base output which then turns the sounder base on. When the smoke clears, the sensor exits the Active Input state, the LEDs turn off, and the zone turns the sounder base off.

If the heat sensor is triggered, it latches into alarm. The detector LED turns on and Alarm is signalled to the zone, which indicates the alarm and activates the alarm devices and alarm routing, etc. The local sounder base will also operate. If this is not desired then a logic equation similar to that in the previous example needs to be used for the functional base output. Resetting the zone will clear the latched heat alarm and indications.

In this example, Zone 10 may have multiple detectors, with or without sounder bases. If all detectors are configured as above, any smoke detector activation will turn on all sounder bases controlled by the zone.

Example Configuration – Local Annunciation plus General Occupant Warning

If the residential application requires the sounder base to be also used as a part of the occupant warning system, this can be achieved by configuring the system as noted above, but then setting the detector’s functional base O/P control to **Zone or Logic**. A logic equation, such as \$ALARM_DEVICES_ON, will need to be entered for the functional base so it is driven by the alarm devices.

With this configuration, the sounder base operates as per the previous example, and in addition it will also operate whenever the alarm devices are turned on.

7.8 Audio Visual Indicator

7.8.1 AVI Wiring

The Audio Visual Indicator Mk2 (AVI) can be used with MX1 to give single or dual stage operation.

If supervision is required, the AVI(s) must be controlled from the Ancillary Relay 3 output of the MX1 Controller. Figure 7.9 shows the wiring for two wire single stage operation with supervision. If supervision is not required, the link from the NC contact to the SUP input of Ancillary Relay 3 can be omitted.

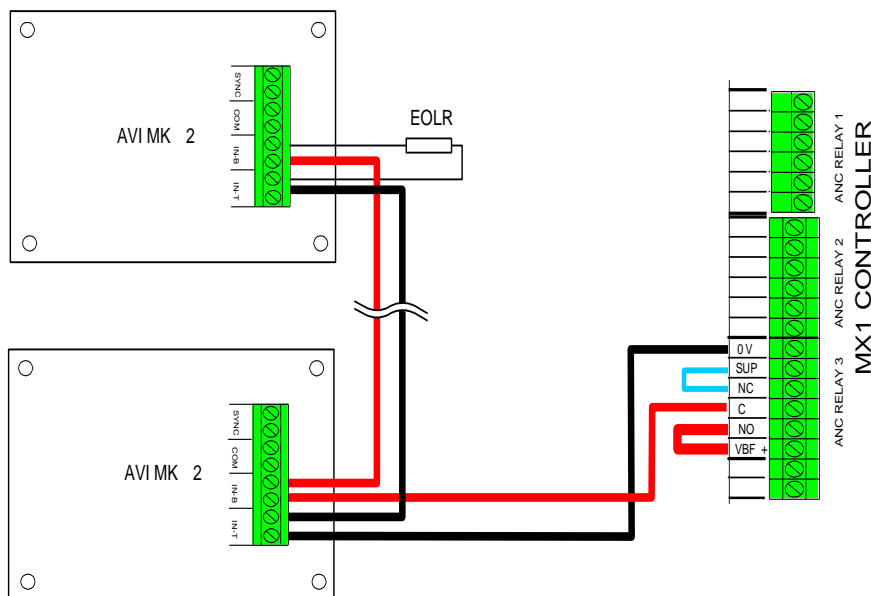

Figure 7.9 – Single Stage AVI Mk2 Operation with Supervision

The ELD value for this circuit should be 9.1kΩ, as supplied with the MX1.

The AVI can be used in single stage operation in conjunction with other multi-branch loads such as Mini-Gen or bells or strobes, controlled by the Ancillary Relay 3.

For two wire, dual stage operation of AVI, an additional relay must be connected to the Ancillary Relay 3 contacts and one of the GP Outputs as shown in Figure 7.10.

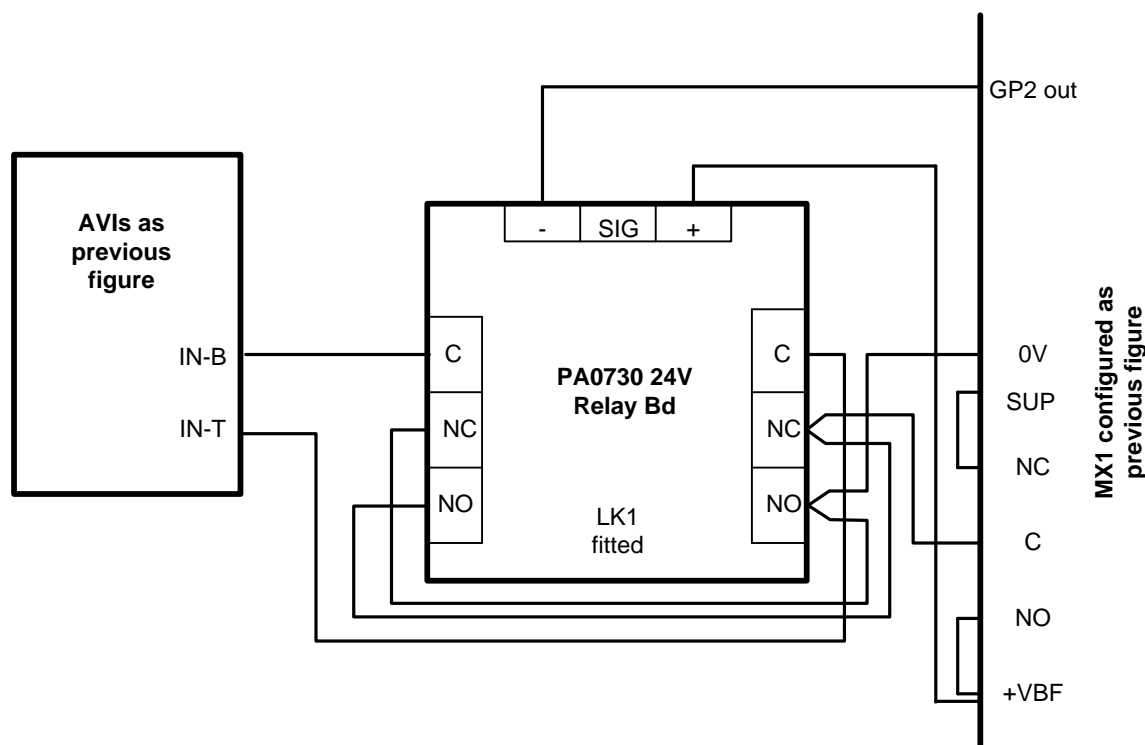

Figure 7.10 – Additional Relay for AVI Dual Stage Operation

With the wiring in Figure 7.10, IN-T will be at +24V and IN-B will be at 0V when Ancillary Relay 3 is operated and GP2 OUT is not activated, giving Stage 1. When GP2 OUT is activated, the voltages at IN-B and IN-T are reversed, giving Stage 2.

7.8.2 Configuration

AVI

Refer to the AVI Installation Instructions (LT0299) for details of setting the links in the AVI to select tone and light combinations.

MX1 Settings in SmartConfig

Single Stage Operation

If supervision is required, in the “Controller Points” window for “Anc3 Supervision” point (ANC3S) set the supervision mode to **ANC3**. Otherwise, set the supervision mode to “None”.

Set the ANC 3 output point’s “O/P Control” field to **\$ALARM_DEVICES_ON**.

Dual Stage Operation

The settings are the same as the single stage operation, but an additional logic equation must be added to activate the GP Output controlling the changeover relay when the Stage 2 conditions are true, i.e. when the zone(s) controlling Stage 2 are in alarm.

Example of Dual Stage Operation

Stage 1 is any alarm present (with Alarm Devices on), but Stage 2 is only when Zones 5 and 6 are both in alarm (with Alarm Devices on). The GP2 Output is used to control the changeover relay, so its “O/P Control” field is set to **Logic** and Logic Cell set as: **\$ALARM_DEVICES_ON AND (Z5AL AND Z6AL)**

7.9 Bell Monitor Board

7.9.1 Introduction

The Bell Monitor Board (PA0494 1864-32-2) can be used to provide an additional 5 amp switched and 3-branch supervised output to external devices (AADs, VADs, etc.).

This could be used for when:

- A load between 3 and 5 amps needs to be switched, and the *MX1* Ancillary Relay 3 is already being used.
- An externally powered load, e.g., from a 12V supply, needs to be controlled.
- Additional branches of loads need to be controlled and supervised.

Note: Only PA0494 circuit revisions REV 3 or higher can be used with *MX1*.

Warning

If the load is greater than 3A an external power supply **MUST** be used. The *MX1*'s onboard +VBF terminals are limited to 3A maximum.

7.9.2 Mounting

The Bell Monitor PCB can be mounted on the gearplate in the *MX1*, either using the adhesive-based plastic standoffs supplied, or the gearplate can be removed and drilled to mount conventional standoffs to hold the PCB.

7.9.3 Wiring

The Bell Monitor can be wired into any of the *MX1* Ancillary Relays 1 or 2. There is little advantage in using Ancillary Relay 3 to drive the Bell Monitor, since it already provides multi-branch supervision.

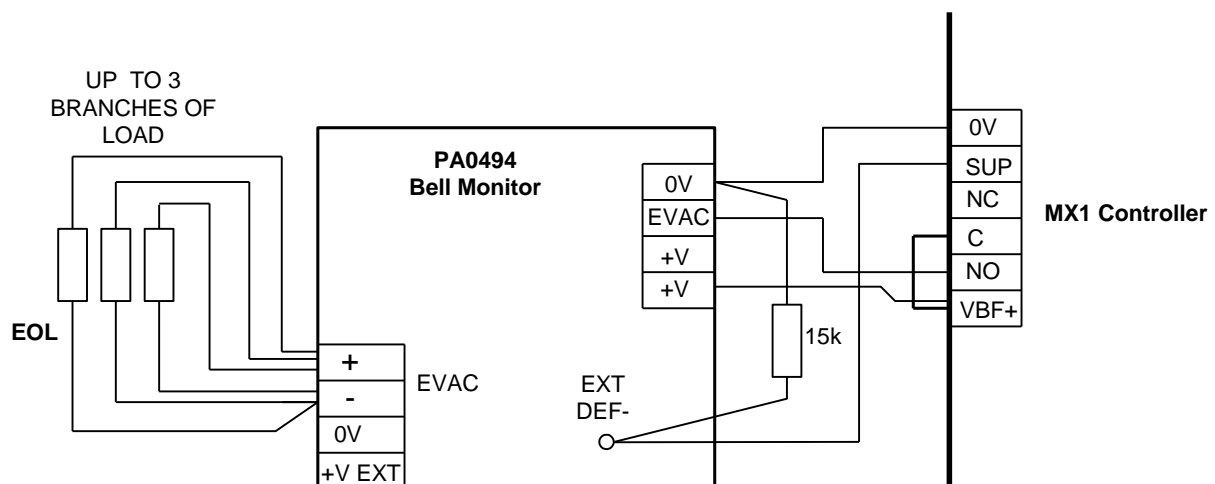

Figure 7.11– 24V Bell Monitor Wiring Details

The Bell Monitor can supervise up to three branches, with a total load of 5A. The ELD values are:

- 1 branch 10kΩ
- 2 branches 18kΩ x 2
- 3 branches 27kΩ x 3

Refer to the Bell Monitor Instructions (LT0190) for details on modifying the board for external isolated power supplies.

In SmartConfig, the *MX1* Ancillary Relay being used to control the Bell Monitor should be set for a Supervision mode of "Load".

7.10 QE90

MX1 can be used to activate a QE90 EWIS in one of several ways:

- Single relay output for all evacuate.
- Multiple relay outputs, one for each zone activation.
- RZDU high level link for individual zone activations.
- Network connection for individual zone activations.

The RZDU and network methods will be described here. The other methods can be derived by using clean-contact relay outputs from *MX1* and supervising the QE90 for fault using a GP Input as shown in Figure 7.12.

RZDU Wiring

Refer to Figure 7.12.

Using the RZDU output is allowed only when the QE90 and *MX1* are co-located, since a single fault on the RZDU wiring will stop all zone alarm signals from working. With this setup the RZDU wiring must not extend beyond the *MX1*/QE90 cabinets (i.e., externally to other RZDU products like NSA or IO-NET) as a short circuit on the external wiring could stop the alarm signalling to the QE90. Section 10.5.4 describes a method to overcome this.

The GP Input ELD is any value between 1.5k Ω and 3.3k Ω .

Refer to the QE90 Installation Manual (LT0088) for details of how to provide the RZDU input in QE90 with a PA0481 Interface. The *MX1*'s RZDU TX and 0V outputs are wired to the RX and 0V inputs on the PA0481.

The QE90's general fault relay (normally energised) C and NC terminals are wired to an *MX1*'s GP input for fault supervision as shown in Figure 7.12. The *MX1* GP Input must be set up as an external fault input as described in section 8.6.

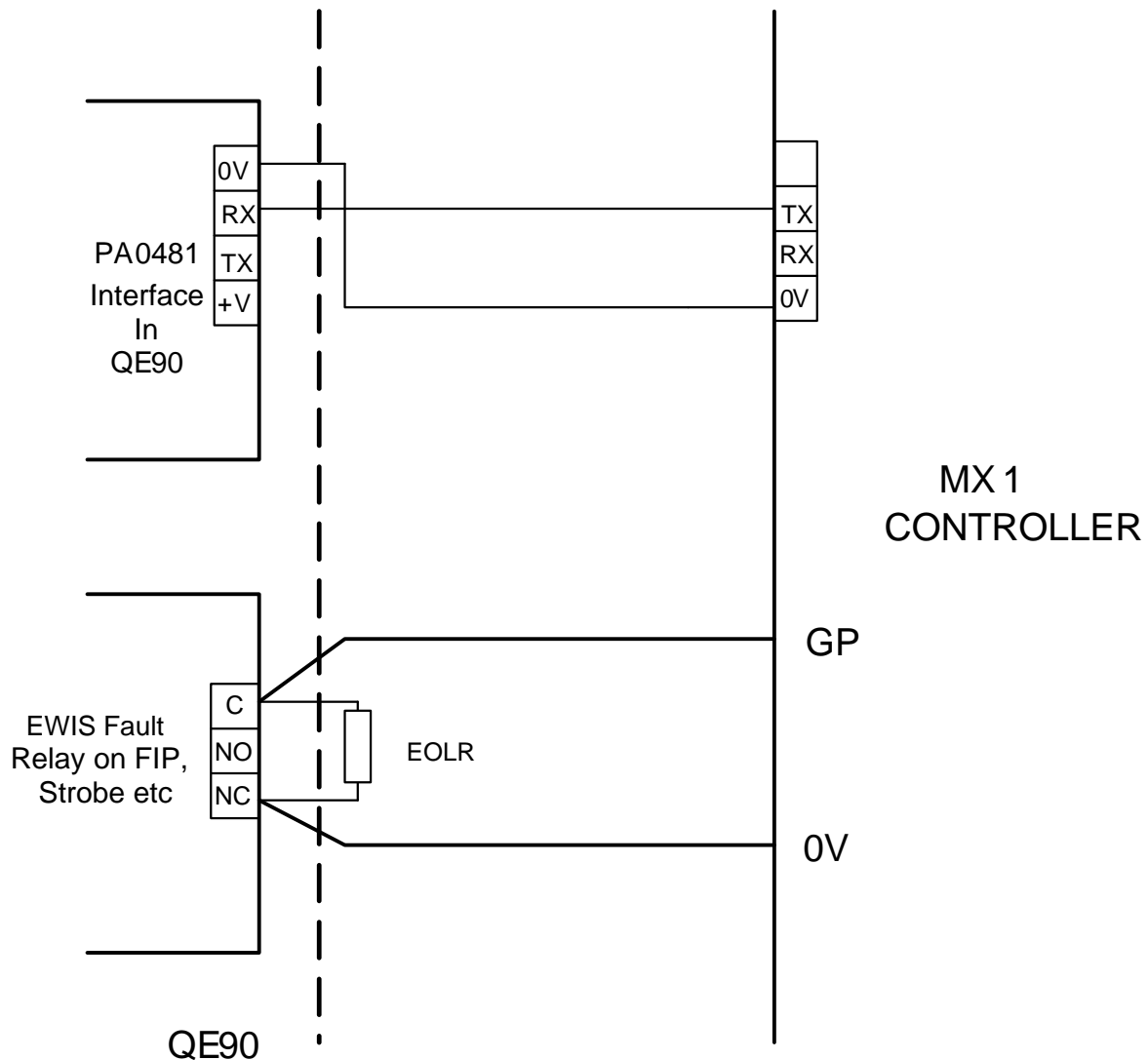

Figure 7.12 – MX1 to QE90 Wiring Using RZDU and EWIS Fault Relay

RZDU Configuration

With other fire panels the usual method to convey alarm information to a QE90 via the RZDU link is to create ACZs and write a logic equation for each ACZ that combines the alarm states of the appropriate fire zones together with the Alarm devices being on. Similarly with *MX1*, except that some extra steps are needed. First, create zones with **ACZ** profiles (say zone 301 up) for the QE90's evacuation zones. Then write the logic equations. For example,

```
;create "zones" for QE90 to look at
Z301OP = Z1AL AND $ALARM_DEVICES_ON
Z302OP = Z2AL AND $ALARM_DEVICES_ON
Z303OP = Z3AL AND $ALARM_DEVICES_ON
Z304OP = Z4AL AND $ALARM_DEVICES_ON
```

Note that each alarm zone's profile needs to activate the alarm devices in order for this logic to work. By including the alarm devices it allows them to be disabled to stop an alarm from triggering the QE90, e.g., during testing. Note though that this will not STOP the QE90 once it has triggered as the inputs latch within the QE90.

Finally, on the System Page set the Maximum Zones of Information value in the RZDU section to the highest zone number to be sent to an RZDU device (RDU, QE90 or whatever is connected to the RZDU data connection).

Network QE90 Connection

If a QE90 and *MX1* panel are connected to the same Panel-Link network, they can be configured so that the *MX1* can activate evacuation zones on the QE90.

The standard method to convey alarm information to a QE90 via a Panel-Link network is to create ACZs and write a logic equation for each ACZ that combines the alarm states of the appropriate fire zones together with the Alarm devices being on. First, create zones with the **QE90 Status Transfer** profile (say zone 301 up) for the QE90's evacuation zones. Then write the logic equations. For example,

```
;create "zones" for QE90 to look at
Z301OP = Z1AL AND $ALARM_DEVICES_ON
Z302OP = Z2AL AND $ALARM_DEVICES_ON
Z303OP = Z3AL AND $ALARM_DEVICES_ON
Z304OP = Z4AL AND $ALARM_DEVICES_ON
```

Note that each alarm zone's profile needs to activate the alarm devices in order for this logic to work. By including the alarm devices it allows them to be disabled to stop an alarm from triggering the QE90, e.g., during testing. Note though that this will not STOP the QE90 once it has triggered as the inputs latch within the QE90.

The *MX1* has to be configured to broadcast the status of its zones out on to the network (the default network operation), and the QE90 has to be configured to map the *MX1* panel's QE90 Status zones to its evacuation zones.

Note the Fault relay output of the QE90 may need to be connected to a fault input on the *MX1*, such as GP1 or GP2, so that an evacuation system fault is signalled to the monitoring service. Refer to Figure 7.12.

For further details please refer to:

LT0564 *MX1* Network Design manual.
LT0088 QE90 Installation and Commissioning manual.

7.11 T-Gen2

MX1 can be used to activate a T-Gen2 using a variety of methods:

- Single relay output for all evacuate (refer section 7.2).
- Multiple relay outputs, one for each zone activation. This could be achieved using the 16 open collector outputs on the LCD/Keyboard. See section 8.21.
- RZDU high level link for individual zone activations.

The RZDU method will be described here.

RZDU Communication Wiring (4-way cable)

Using the RZDU output of the MX1 to trigger the T-Gen2 is allowed only when the MX1 and T-Gen2 cabinets are co-located, since a single fault on the RZDU field wiring will stop all zone alarm signals from working. The T-Gen2 HLI Module (FP1143) is mounted in either the MX1 and T-Gen2 cabinet and the MX1 RZDU output is wired to the RZDU FIP terminals (J3) on the HLI Board – see figure 7.13.

Any RZDU field devices must be wired to J4 of the HLI board so that a short circuit does not stop any communication between the T-Gen2 and MX1 panel.

The MX1's RZDU +V and 0V outputs are wired to the +V and 0V inputs on the HLI Module. The TX and RX wires are cross-over connected. The TX and RX outputs of the HLI board to the RZDU FIELD devices are cross-over connected to the first device as well.

A 10-way FRC cable connects the HLI Module J2 to the T-Gen2 MX1 Comms connector J29.

Links Lk1-4 on the HLI Board need to be set to the RZDU positions.

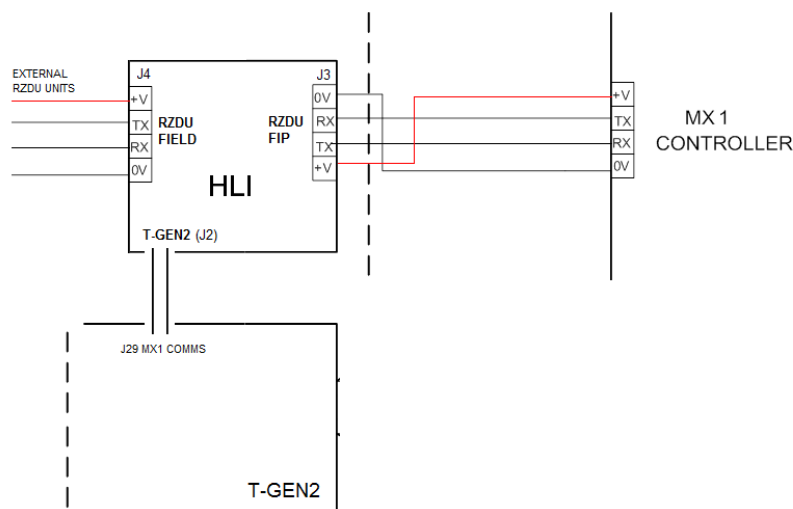

Figure 7.13 – MX1 to T-Gen2 Wiring Using RZDU and HLI (FP1143)

MX1 Direct Communication (10-way ribbon cable)

When there are no field RZDU devices to be connected to the MX1 and the MX1 and T-Gen2 cabinets are adjacent then the T-Gen2 can be connected directly to the MX1 panel using a 10-way ribbon cable between J29 (T-Gen2) and any free available serial port (2, 3, 4) on the *MX1* panel.

Configure the RZDU Hardware interface Equipment 244 for MX1 in SmartConfig to use the selected Serial Port.

Configuration for HLI

To configure the MX1 panel for the HLI RZDU setup, the following is required:

- 1) Enable an RZDU device for the T-Gen2.
- 2) Select a range of 32 zones to be used to convey the alarm information to the T-Gen2. For example zones 301 up.
- 3) Select the Zone Type Profile for these zones to be ACZ.
- 4) Enter valid logic equations for each of the zone outputs to collect the MX1 states required to trigger the T-Gen zone input.

Program the Logic Equations in the MX1 panel. For example.

$$Z301OP = (Z1AL + Z2AL + ADT).^ADS$$

This equates to Zone 1 Alarm or Zone 2 Alarm or Warning System Test, and not Warning System Silence (isolated). It will be sent to the T-Gen2 as an alarm on Zone 301.

An example to play a message on the T-Gen2 when an MX1 input is activated (not controlled by Alarm Devices).

$$Z302OP = P1/1/1AL$$

Also, the T-Gen2 needs to be configured.

On the General Table of SmartConfig select the **Vigilant RZDU** High Level Link option, set the **Start FIP Zone / Point** to 301 (or the first zone selected in the MX1 to convey the T-Gen2 triggers), and set **RZDU / Slave Address** to the RZDU address enabled for the T-Gen2 in the *MX1* Panel. Tick **Reply to FIP**, to ensure the T-Gen2 sends its status to the *MX1*. Usually the Alarm State will have **Latching** not ticked, so the *MX1* Warning System state controls the T-Gen2.

For mapping the *MX1* RZDU signals to specific functions on the T-Gen2, a separate **HLL Inputs** table is provided within SmartConfig. Each of the 32 HLI Inputs can be given one of the T-Gen2 built-in functions: None, Alarm Trigger, AIE, Play Signal, Paging Line 1, Paging Line 2, EXT Power FLT, EXT Mains FLT or EXT Audio FLT. For example, to trigger alarm on a T-Gen2 zone, select Alarm Trigger and enter the T-Gen2 zone number. Continuing the above example, on the row for Zone 301 select Alarm Trigger and enter Zone 1.

7.12 QE20

MX1 can activate a QE20 EWS using a variety of methods:

- Single relay output for all evacuate.
- Multiple relay outputs, one for each zone activation.
- RZDU high level link for individual zone activations.
- Network connection for individual zone activations.

Single Relay for ALL Evacuate

The MX1 ANC1 relay and supervision input (or ANC2) can be used for all evacuate if the MX1 and QE20 are co-located (adjacent panels or a combo). Figure 7.14 shows the wiring.

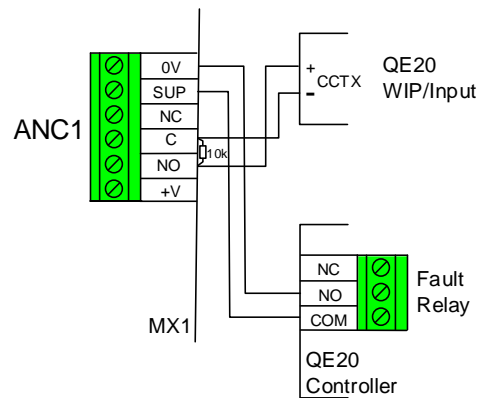

Figure 7.14 – Wiring MX1 ANC1 to QE20

Multiple Relays, One for Each QE20 Zone

If the MX1 and QE20 are not co-located, or multiple zone inputs to the QE20 are required, then separate relays must be used for each QE20 zone alarm and a supervised fault input is needed on the MX1.

A 16-way relay board can be fitted to the MX1 to provide multiple relay outputs (refer Section 8.21.3). The GP1 or GP2 input needs to be configured for Ext Fault (see Section 8.6). Figure 7.15 shows the wiring between the MX1 and QE20.

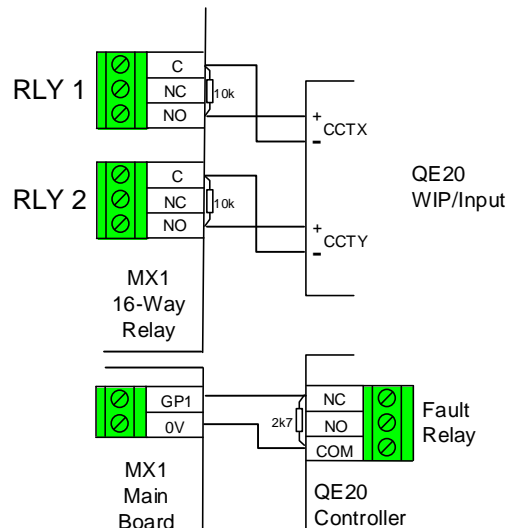

Figure 7.15 – Multiple MX1 Relays to QE20

RZDU High Level Link for Individual QE20 Zones

The RZDU output can be used only when the QE20 and MX1 are co-located, since a single fault on the RZDU wiring will stop all zone alarm signals from working. With this setup the RZDU wiring must not extend beyond the MX1/QE20 cabinets (i.e., externally to other RZDU products like NSA or IO-NET) as a short circuit on the external wiring could stop the alarm signalling to the QE20.

If RZDU wiring to field devices is required, then the FP1143 HLI Interface Module needs to be added to provide a short-circuit isolated field RZDU connection.

Refer to drawing 1976-181 Sheet 139 in LT0442 for the wiring details. Note a connection is not required from the QE20 Fault relay, as the MX1 RZDU communications will create a fault if the QE20 powers down, is disconnected, or is in the fault condition.

MX1 Configuration

First, in SmartConfig create zones with **ACZ** profiles (say zone 301 up) for the QE20’s evacuation zones. Then write the logic equations to activate each ACZ when the required MX1 zone(s) is in alarm and the Alarm Devices are on.

```

;create "zones" for QE20 to look at
Z301OP = Z1AL AND $ALARM_DEVICES_ON
Z302OP = Z2AL AND $ALARM_DEVICES_ON
Z303OP = Z3AL AND $ALARM_DEVICES_ON
Z304OP = Z4AL AND $ALARM_DEVICES_ON
    
```

Note that each alarm zone’s profile needs to activate the alarm devices in order for this logic to work. By including the alarm devices it allows them to be disabled to stop an alarm from triggering the QE20, e.g., during testing. Note though, that this will not STOP the QE20 once it has been triggered as the alarm inputs latch within the QE20.

On the System Page enable the RZDU number that will be assigned to the QE20 and set the Maximum Zones of Information value in the RZDU section to the highest zone number to be sent to an RZDU device (RDU, QE20 or whatever is connected to the RZDU data bus).

The QE20 will need to be configured using QEConfig for RZDU HLL Inputs; enter the assigned RZDU number (address) and map each *MX1* ACZ zone to the required emergency zone FIP input using Hx, where x is the *MX1* ACZ number.

Network QE20 Connection

If a QE20 and *MX1* panel are connected to the same Panel-Link network, they can be configured so that the *MX1* can activate evacuation zones on the QE20 and monitor the fault state of the QE20 over the network.

The standard method to convey alarm information to a QE20 via a Panel-Link network is to create ACZs and write a logic equation for each ACZ that combines the alarm states of the appropriate fire zones together with the Alarm devices being on.

First, in SmartConfig, create zones with the **QE90 Status Transfer** profile (say zone 301 up) for the QE20's evacuation zones. Then write the logic equations. For example,

```
;create "zones" for QE20 to look at
Z301OP = Z1AL AND $ALARM_DEVICES_ON
Z302OP = Z2AL AND $ALARM_DEVICES_ON
Z303OP = Z3AL AND $ALARM_DEVICES_ON
Z304OP = Z4AL AND $ALARM_DEVICES_ON
```

Note that each alarm zone's profile needs to activate the alarm devices in order for this logic to work. By including the alarm devices it allows them to be disabled to stop an alarm from triggering the QE20, e.g., during testing. Note though, that this will not STOP the QE20 once it has been triggered as the alarm inputs latch within the QE20.

The *MX1* has to be configured for networking and to broadcast the status of its zones out on to the network (the default network operation).

On the SID Points page the SID number assigned to the QE20 needs to be set to a Type of **QE90**, and the SID Config Profile set to **QE90**. This will make the *MX1* generate a fault if the QE20 does not respond over the network, or if the QE20 sends a MAF Status message with System Fault present. Wiring of the QE20 Fault relay to the *MX1* is thus not required.

The QE20 will need to be configured for networking, and each *MX1* ACZ zone entered as the FIP input using Hx.y (where x = *MX1* SID, y = ACZ number) for each QE20 emergency zone.

For further details refer to:

LT0564 *MX1* Network Design Manual
LT0726 QE20 Design Manual.

8 Miscellaneous Applications

8.1 General

As well as the usual detector and alarm devices configurations, many installations will require other miscellaneous functions which are specific to that installation.

The following sections describe the equipment that can be mounted on the gearplate or the 19" rack of the *MX1* cabinet.

Some functions require changes or extensions to the common or default processing in the *MX1*. These extensions can be readily made by using the flexibility of the *MX1*'s configuration.

This flexibility arises from the ability to change aspects such as the designations of the input voltage bands on devices and Controller inputs, select different modes of supervision on outputs, and the boolean logic equations which control much of the *MX1*'s internal operation.

In the following examples, fragments of SmartConfig tables and logic equations are used to show the form of the requirements. To use these in any particular installation, the table entries and equations must be adjusted as required to match the specific aspects of the particular installation and configuration.

8.2 Cabinet Options

8.2.1 19" Rack Cabinet Options

The standard 8U and 15U 19" rack cabinets provide options for mounting equipment internally on the gearplate and on the 19" rack.

Mounting holes are provided on the gearplates for many standard modules such as T-Gen2, 100V Splitter Board, 100V Switching Board, T-GEN 50, Mini-Gen, ISO 8201 Strobe Driver, *MX* Loop card, *MX* modules, I-HUB (ECM), PIB, GP Relay Board, Fuse Board, networking equipment, etc. Drawings 1982-71 sheets 152 to 160 show various mounting arrangements for the 8U gearplate. Drawings 1982-71 sheets 140, 141, 142, 143, 144, 148, 149 and 169 show various mounting arrangements for the 15U gearplate. Note that not all combinations are possible due to overlapping positioning.

The 19" rack may be fitted with a number of different modules, but there are physical limits as to which modules may be mounted in each position. What modules are mounted on the gearplate affects what items can be mounted on the 19" rack (and vice versa), so not all combinations of equipment are compatible. Tables 8.1 and 8.2 show some possibilities, plus some of the conflicts between modules. In Table 8.2 the X/X/X possibilities indicate if the module can be fitted with: no *MX* Loop Card (or other modules) on brackets on the gear plate/any in the top positions/any in the bottom positions on the gearplate. This assumes all 3 positions are occupied.

Matching 8U and 15U expansion cabinets (FP1029, FP1030 and FP1031) are available, plus a full height window 15U cabinet (FP1084). These need to be mounted immediately adjacent to the *MX1* cabinet.

Other possibilities are available with BTO (build-to-order) systems. Consult the *MX1* BTO documentation for information.

Networking options are discussed in Section 14.

Table 8.1 – MX1 8U Cabinet Rack Mounting Possibilities

U Position (Top)	4U MX1 LCD Display Door ME0462	2U 4 x AS1668 Door (ME0472)	3U ASE Door KT0199	3U QLD/WA ASE Door (Cube) FZ9028	3U QLD/WA Door (WA ASE) (FZ9028)	1U T-GEN50 Control Panel ME0289	3U Door Grade 2 UI (FP1125)	Various Blank Panels
1	Y	Y	Y	Y	N	Y	Y	Y
2	Y	Y	Y	Y	N	Y	Y	Y
3	Y	Y	Y	Y	Y	Y	Y	Y
4	Y	Y	Y	Y	Y	Y	Y	Y
5	Y	Y	Y	Y	Y	Y	Y	Y
6	-	Y	Y	Y	Y	Y	Y	Y
7	-	Y	-	-	-	Y		Y
8	-	-	-	-	-	Y		Y

Key

Y Bold letters indicate preferred position in cabinet

^ Battery space limited to 17Ah in an 8U cabinet

- Not possible to fit top of module here!

Note: Bottom 2U not visible due to door window height

Table 8.2 – MX1 15U Cabinet Rack Mounting Possibilities

U Position (Top)	4U MX1 LCD Display Door (ME0462)	4U 5 x 16 Zone Display Door (ME0457)	3U T-GEN 50 Door (FP0698) 3U T-Gen2 Grade 3 UI Door (FP1121)	3U 12 x AS1668 Door (FP1056) 3U T-Gen2 Grade 3 UI Door (FP1122)	3U T-Gen2 Grade 2 UI Door (FP1124)	3U ASE Door (KT0199)	3U 2 x V-Modem Door (KT0212)	3U QLD/WA ASE Door (Cube) FZ9028	3U QLD/WA Door (WA ASE) (FZ9028)	1U Doc Tray (135 Deep) (ME0258)	1U T-GEN50 Control Panel (ME0289)	Various Blank Panels
1	Y	Y	Y/N/Y	Y	Y	Y	Y/N/Y	Y	N	N	Y	Y
2	Y	Y	Y/N/Y	Y	Y	Y	Y/N/Y	Y	N	N	Y	Y
3	Y	Y	Y/N/Y	Y	Y	Y	Y/N/Y	Y	Y	Y/N/Y	Y	Y
4	Y	Y	Y/Y/Y	Y	Y	Y	Y/N/Y	Y	Y	Y/N/Y	Y	Y
5	Y	Y	Y/Y/N	Y	Y	Y	Y/N/N	Y	Y	Y/N/Y	Y	Y
6	Y	Y	Y/Y/N	Y	Y	Y	Y/Y/N	Y	Y	Y/Y/#	Y	Y
7	Y	Y	Y/Y/N	Y	Y	Y	Y/Y/N	Y	Y	Y/Y/#	Y	Y
8	Y	Y	Y/Y/N	Y	Y	Y	Y/Y/N	Y	Y	Y/Y/#	Y	Y
9	Y	Y	Y/Y/Y	Y	Y	Y	Y/Y/N	Y	Y	Y/Y/#	Y	Y
10	Y*	Y	Y/Y/Y	Y	Y	Y	Y/Y/N	Y	Y	Y/Y/#	Y	Y
11	Y*	Y	Y^	Y	Y	Y^	Y^	Y^	Y^	Y	Y	Y
12	Y*	Y	Y^	Y^	Y^	Y^	Y^	Y^	Y^	Y	Y	Y
13	-	-	Y^	Y*	Y*	Y^	Y^	Y^	Y^	N	Y*	Y
14	-	-	-	Y*	Y*	-	-	-	-	N	Y*	Y
15	-	-	-	-	-	-	-	-	-	N	N	Y

Key

Y Bold letters indicate preferred position in cabinet

X/X/X Possibility, depending on whether any MX Loop brackets, 100V Switch/Splitter Boards, T-Gen 120 (or other boards) are mounted on Loop Card brackets on the gearplate in positions: None/top/bottom.

Not available if T-Gen2, T-GEN 50 or Mini-Gen boards fitted to gear plate

***** Not available if 40Ah Batteries fitted in bottom of cabinet

^ If fitted, battery space limited to 17Ah

- Not possible to fit top of module here!

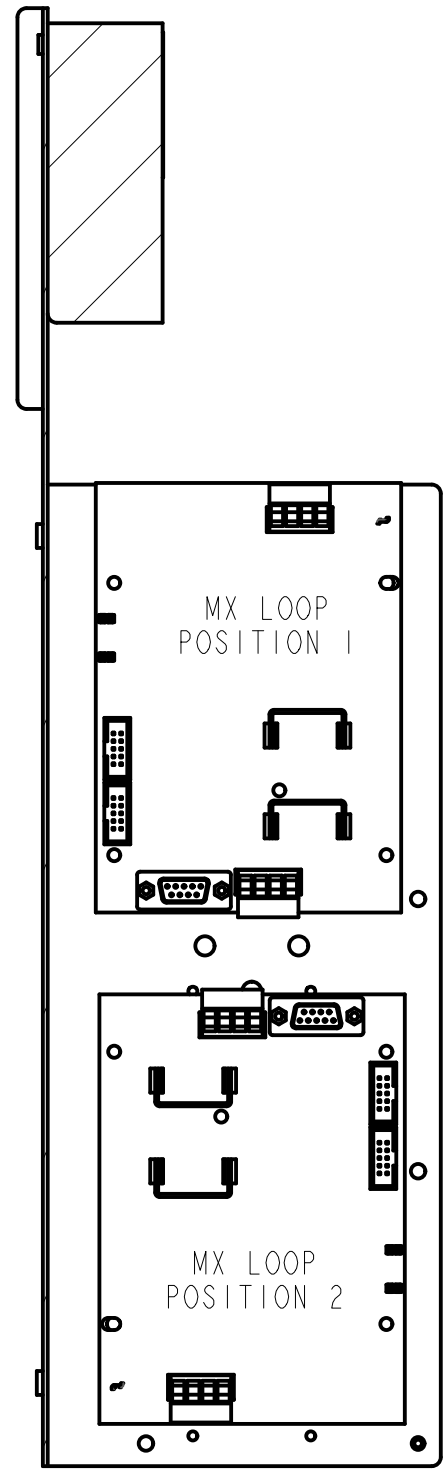
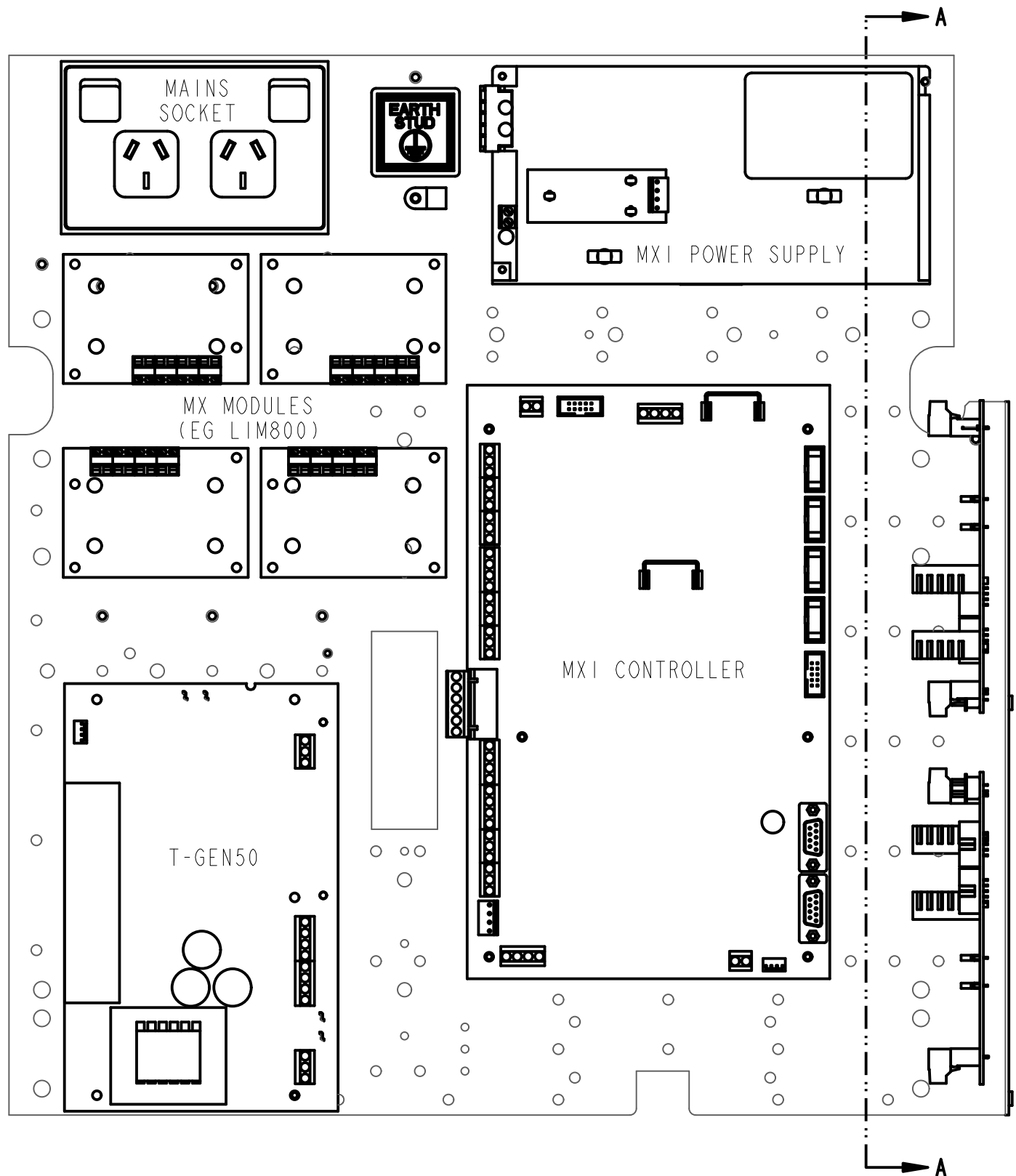

SECTION A-A

NOTES:

1. MOUNT T-GEN 50 USING 5 PLASTIC STAND-OFFS (HW0130) AND 1 OFF M3 X12 SCREW (SC0177). CENTRE LEFT PLASTIC STAND-OFF WILL NEED ITS RETAINING CLIP REMOVED. STAND-OFFS FACTORY FITTED FROM GEAR PLATE REAR.
2. MOUNT MX LOOP CARD USING 4 PLASTIC DOUBLE BARB STAND-OFFS (HW0052) SUPPLIED IN KIT. STAND-OFFS FITTED FROM GEAR PLATE FRONT.
3. MOUNT MX MODULES USING 4 PLASTIC DOUBLE BARB PCB STAND-OFFS (HW0052) FITTED FROM FRONT OF GEAR PLATE.

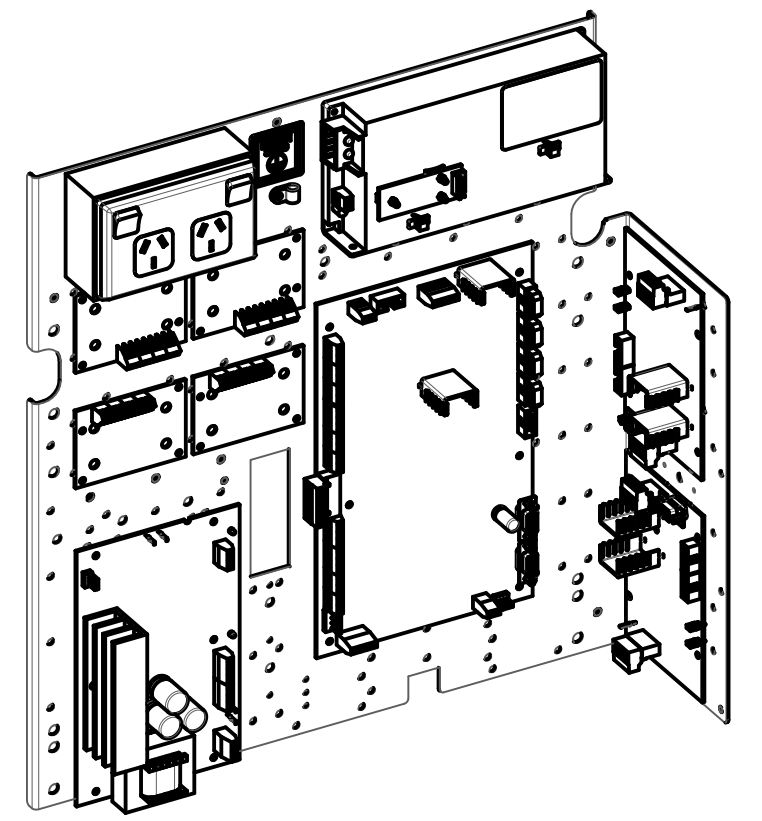

ISOMETRIC VIEW
SCALE 0.200

CONFIDENTIAL. THIS DOCUMENT MUST NOT BE COPIED NOR THE CONTENTS PASSED ON TO ANY THIRD PARTY WITHOUT THE CONSENT OF THE COMPANY.

UNLESS OTHERWISE STATED: ALL DIMENSIONS IN MILLIMETRES. DO NOT SCALE. TOLERANCES ARE TO BE: 1 DECIMAL PLACE ± 0.5 , 2 DECIMAL PLACES ± 0.3 , 3 DECIMAL PLACES ± 0.1

3rd ANGLE PROJECTION

ISS/REV	AMENDMENTS	ECO	DRN	CHKD	AUTH	APVD	DATE
B	UPDATED FOR NEW REV GEAR PLATE.	4167	KJS	LSC	RC	DP	20-08-10

tyco
Fire Protection Products
 TYCO FIRE PROTECTION PRODUCTS
 17 MARY MULLER DRIVE
 P.O. BOX 19545
 CHRISTCHURCH, PH: +64 3 3895096
 NEW ZEALAND. FAX: +64 3 3895938

MX1		
T-GEN50, MX MODULES, MX LOOP		
GEARPLATE POSITIONS		
DRAWING No: 1982-71		SHEET 140 of N
A3	ISS/REV B	PART No:

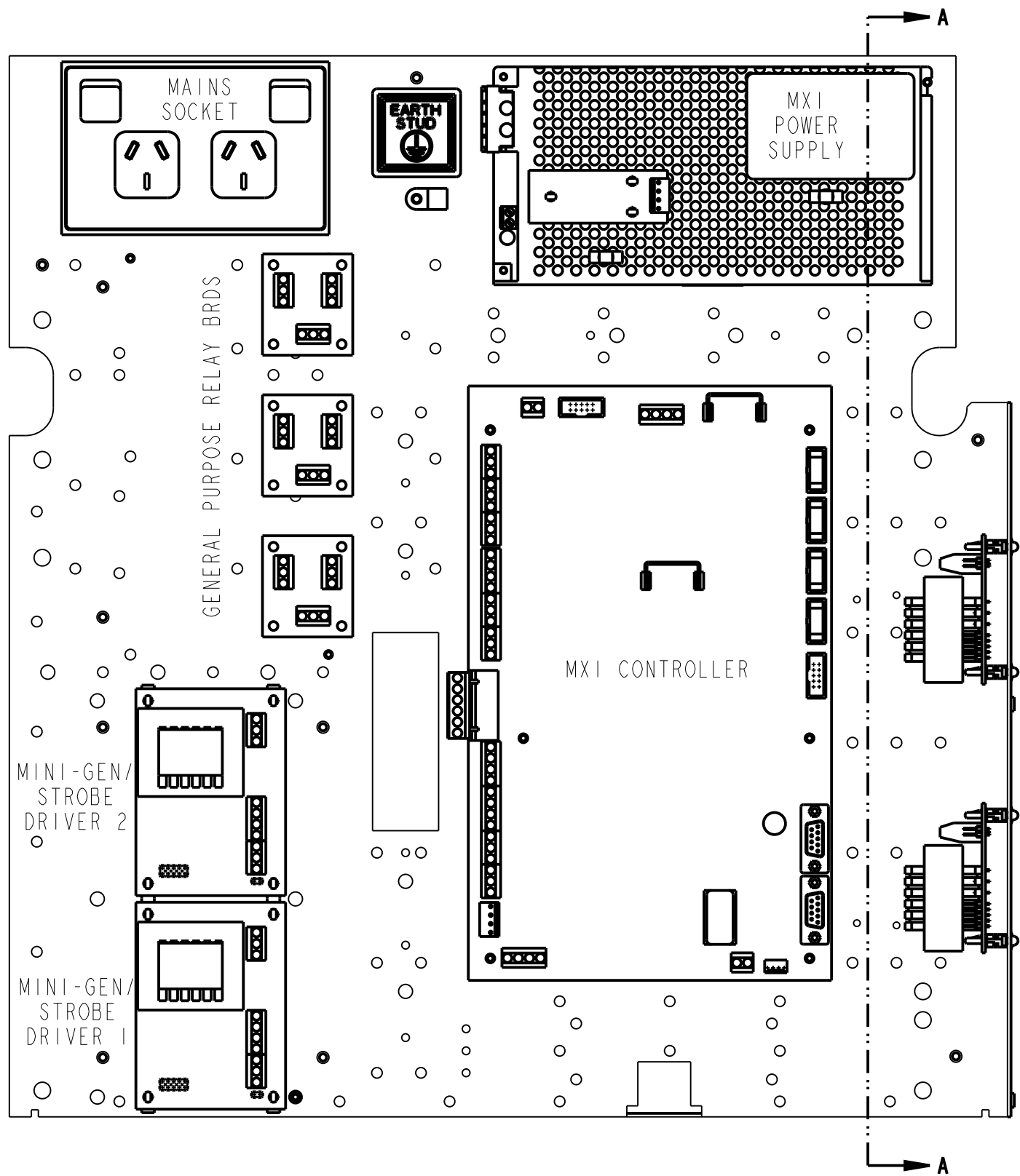

NOTES:

1. MOUNT MINI-GEN OR STROBE DRIVER USING 4 PLASTIC DOUBLE BARB PCB STAND-OFFS (HW0052) FITTED FROM FRONT OF GEAR PLATE.
2. MOUNT GENERAL PURPOSE RELAY BOARDS USING 4 PLASTIC DOUBLE BARB PCB STAND-OFFS (HW0052) PER BOARD, FITTED FROM FRONT OF GEAR PLATE.

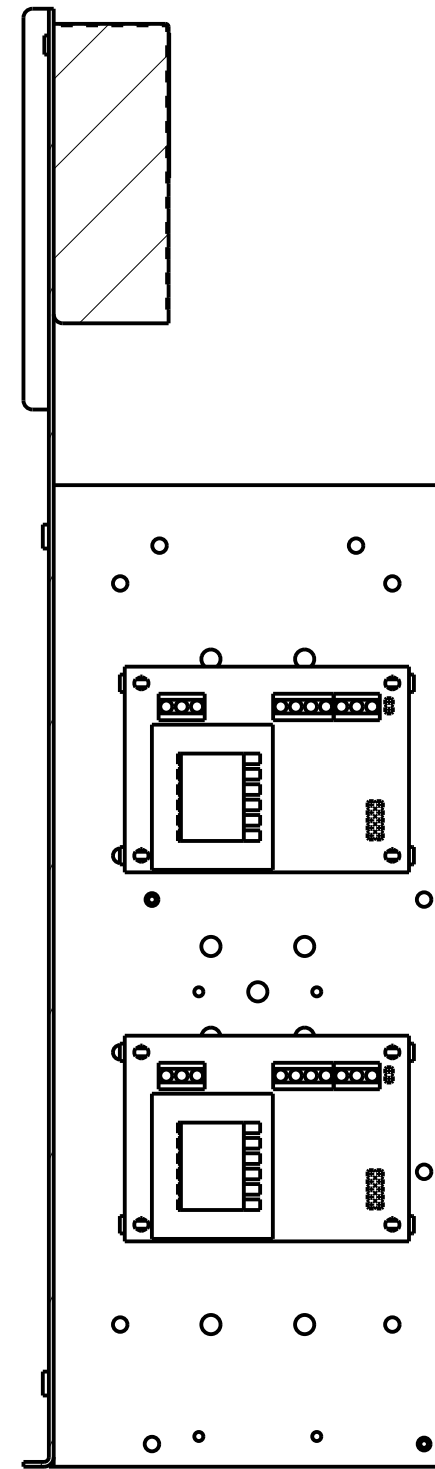

SECTION A-A

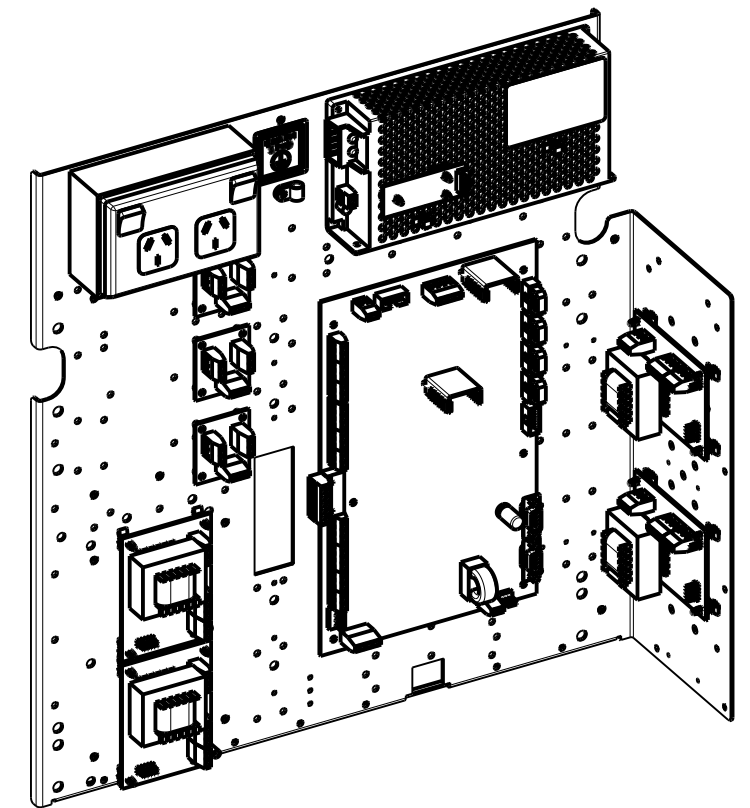

ISOMETRIC VIEW
SCALE 0.200

CONFIDENTIAL. THIS DOCUMENT MUST NOT BE COPIED NOR THE CONTENTS PASSED ON TO ANY THIRD PARTY WITHOUT THE CONSENT OF THE COMPANY.

UNLESS OTHERWISE STATED: ALL DIMENSIONS IN MILLIMETRES. DO NOT SCALE. TOLERANCES ARE TO BE: 1 DECIMAL PLACE ± 0.5 , 2 DECIMAL PLACES ± 0.3 , 3 DECIMAL PLACES ± 0.1

3rd ANGLE PROJECTION

ISS/REV	AMENDMENTS	ECO	DRN	CHKD	AUTH	APVD	DATE
B	UPDATED FOR NEW REV GEAR PLATE.	4167	KJS	LSC	RC	DP	20-08-10
C	GP RELAY BRDS WERE ON SHEET 149.	-	KJS	RC	RC	DP	11-4-13

tyco
Fire Protection Products

TYCO FIRE PROTECTION PRODUCTS
17 MARY MULLER DRIVE
P.O. BOX 19545
CHRISTCHURCH, PH: +64 3 3895096
NEW ZEALAND. FAX: +64 3 3895938

MX1 MINI-GEN / STROBE DR / GP RELAY GEARPLATE POSITIONS		
DRAWING No: 1982-71		SHEET 141 of N
A3	ISS/REV C	PART No:

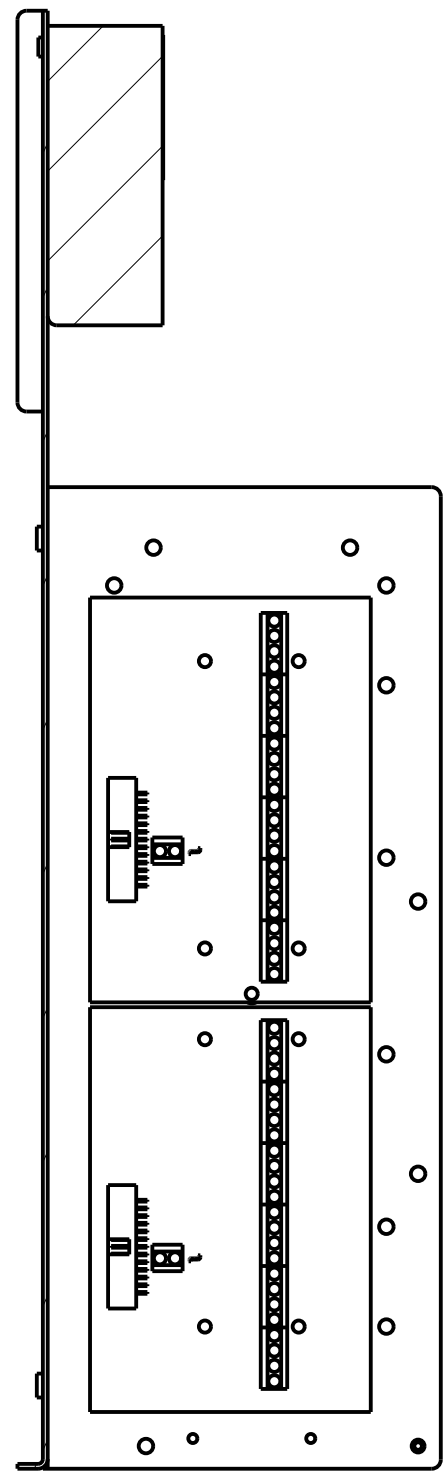
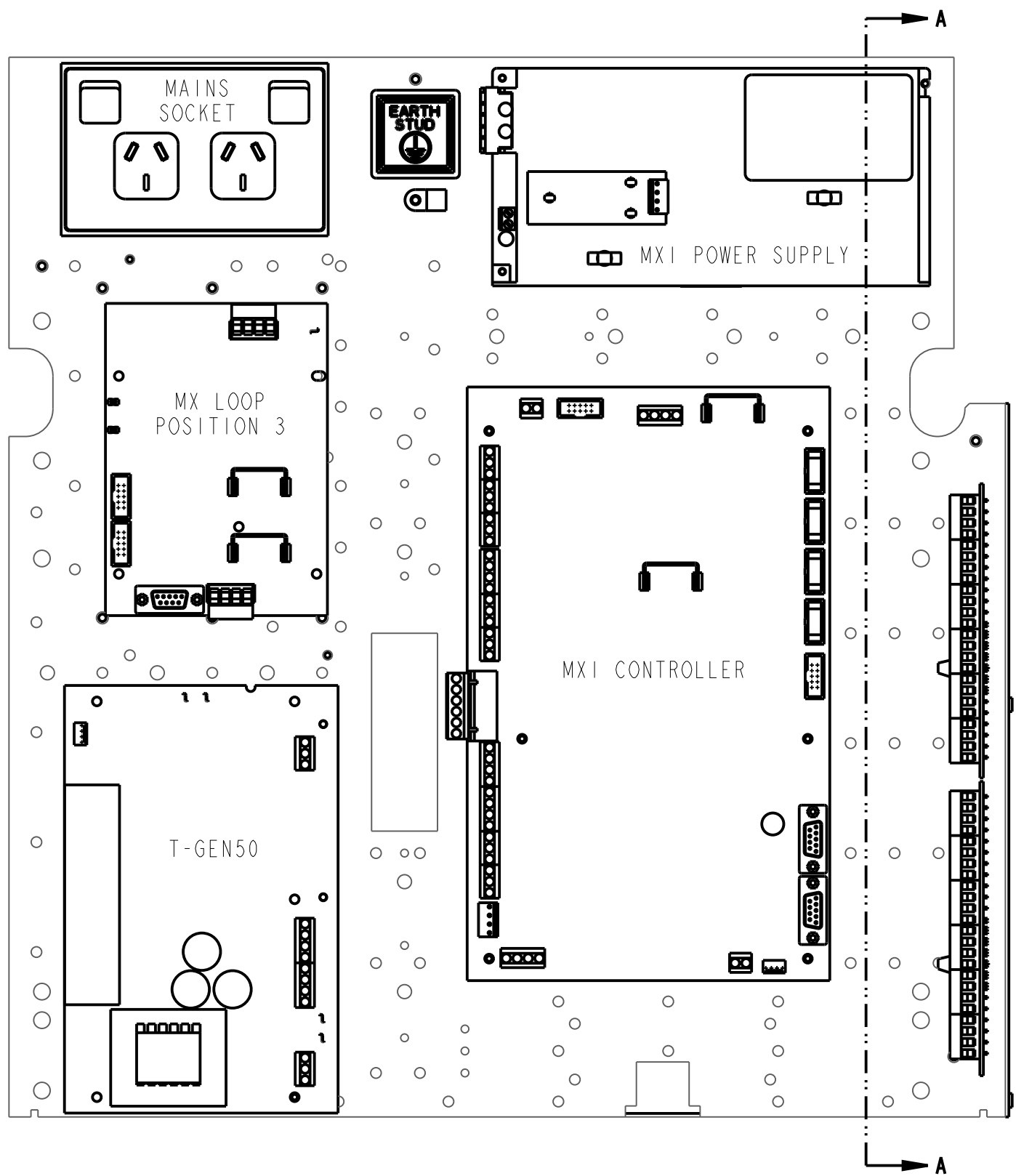

SECTION A-A

NOTES:

1. MOUNT 16 WAY INPUT AND 16 WAY OUTPUT BOARDS USING 4 PLASTIC PCB STAND-OFFS (HW0130) FITTED FROM REAR OF GEAR PLATE SIDE FOLD.
2. MOUNT MXI LOOP CARD USING 4 PLASTIC DOUBLE BARB PCB STAND-OFFS (HW0052) FITTED FROM FRONT OF GEAR PLATE.

16 WAY INPUT BRD

16 WAY OUTPUT BRD

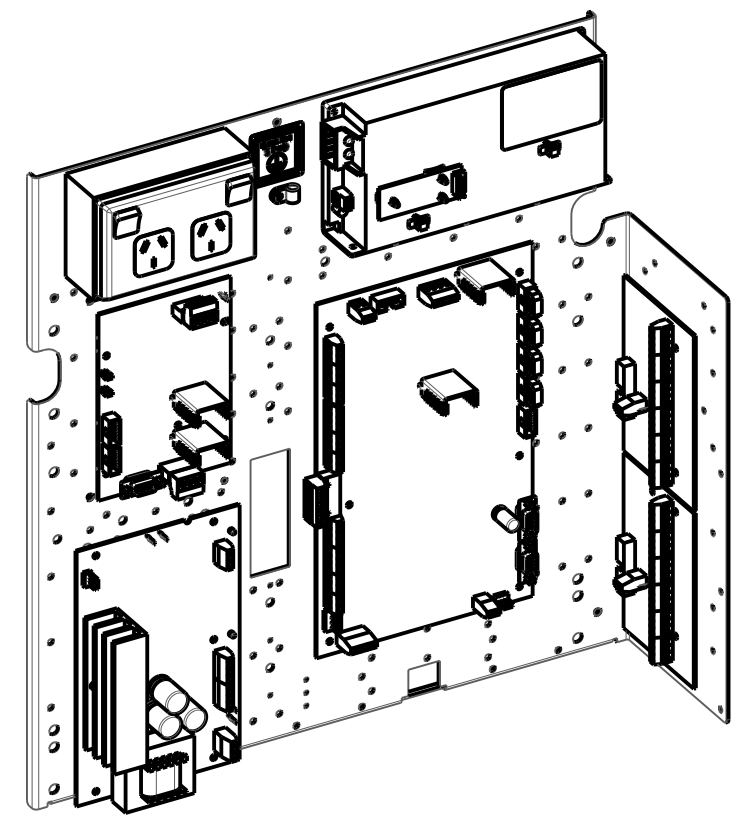

ISOMETRIC VIEW
SCALE 0.200

CONFIDENTIAL. THIS DOCUMENT MUST NOT BE COPIED NOR THE CONTENTS PASSED ON TO ANY THIRD PARTY WITHOUT THE CONSENT OF THE COMPANY.

UNLESS OTHERWISE STATED: ALL DIMENSIONS IN MILLIMETRES. DO NOT SCALE. TOLERANCES ARE TO BE: 1 DECIMAL PLACE ±0.5, 2 DECIMAL PLACES ±0.3, 3 DECIMAL PLACES ±0.1

3rd ANGLE PROJECTION

ISS/REV	AMENDMENTS	ECO	DRN	CHKD	AUTH	APVD	DATE
B	UPDATED FOR NEW REV GEAR PLATE.	4167	KJS	LSC	RC	DP	20-08-10

tyco
Fire Protection Products
 TYCO FIRE PROTECTION PRODUCTS
 17 MARY MULLER DRIVE
 P.O. BOX 19545
 CHRISTCHURCH, PH: +64 3 3895096
 NEW ZEALAND. FAX: +64 3 3895938

MX1
16 INPUT, 16 OUTPUT, MX LOOP CARD
GEARPLATE POSITIONS

DRAWING No: **1982-71** SHEET **142** of **N**

A3	ISS/REV B	PART No:
-----------	------------------	----------

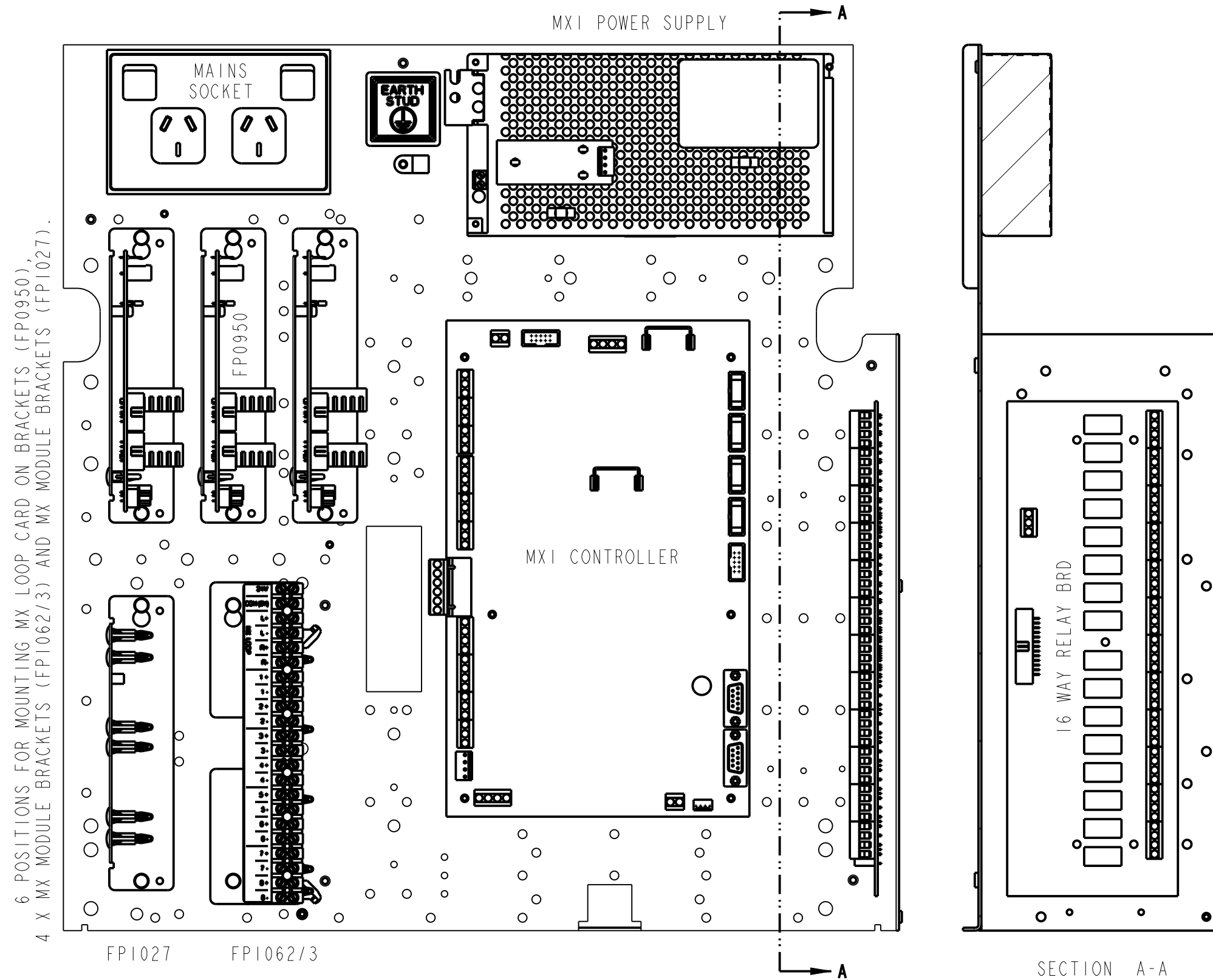

6 POSITIONS FOR MOUNTING MX LOOP CARD ON BRACKETS (FP0950),
4 X MX MODULE BRACKETS (FPI062/3) AND MX MODULE BRACKETS (FPI027).

NOTES:

1. MOUNT 16-WAY RELAY BOARD ON GEAR PLATE USING 5 PLASTIC STAND-OFFS (HW0130) FITTED FROM REAR OF GEAR PLATE SIDE FOLD.
2. MOUNT EACH BRACKET MOUNTED MX LOOP CARD WITH 2 OFF M4 X 10 SCREWS (SC0176). SCREWS FITTED FROM GEAR PLATE FRONT.
3. MOUNT EACH MX MODULE MOUNTING BRACKET (FPI027, FPI062, FPI063) WITH 2 OFF M4 X 10 SCREWS (SC0176). SCREWS FITTED FROM GEAR PLATE FRONT.
4. MOUNT MX MODULES ON FPI027 BRACKET USING 4 PLASTIC PCB STAND-OFFS (HW0131) PROVIDED WITH BRACKET.
5. MOUNT MX MODULES ON FPI062 BRACKET USING 4 PLASTIC PCB STAND-OFFS (HW0209) PROVIDED WITH BRACKET.

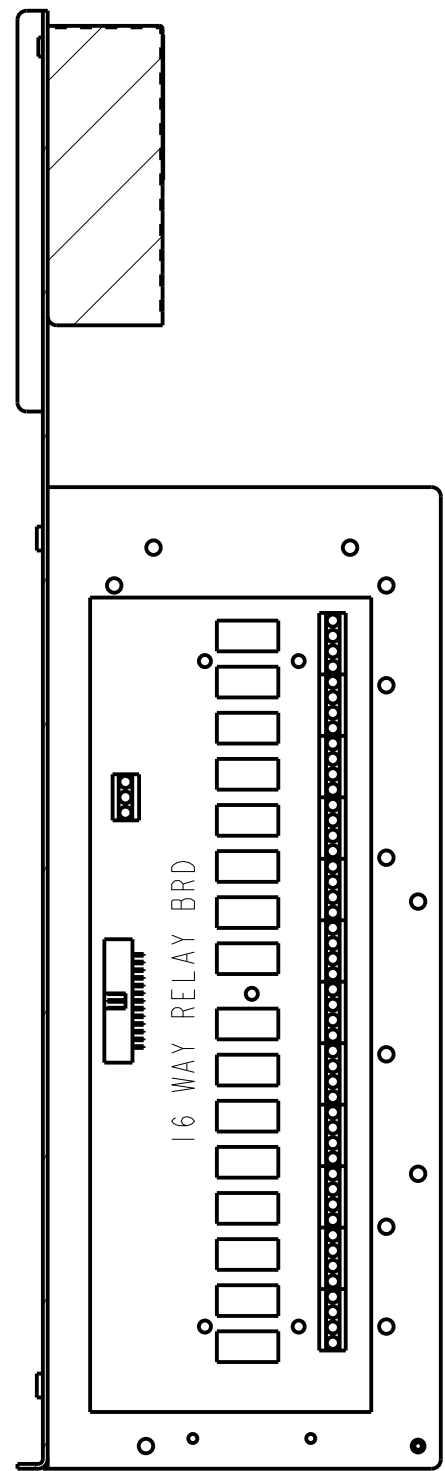

SECTION A-A

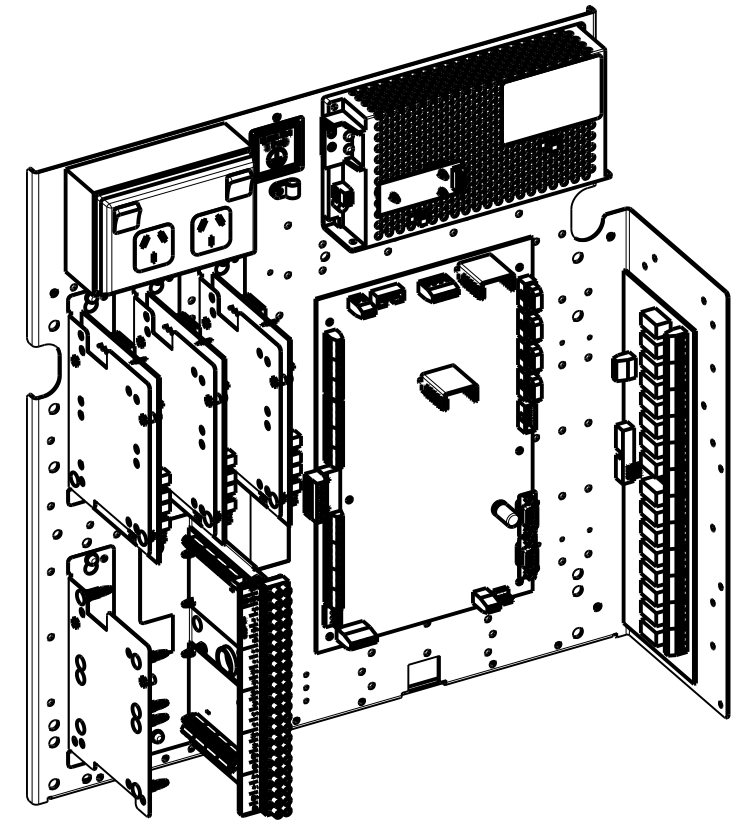

ISOMETRIC VIEW
SCALE 0.200

CONFIDENTIAL. THIS DOCUMENT MUST NOT BE COPIED NOR THE CONTENTS PASSED ON TO ANY THIRD PARTY WITHOUT THE CONSENT OF THE COMPANY.

UNLESS OTHERWISE STATED: ALL DIMENSIONS IN MILLIMETRES. DO NOT SCALE. TOLERANCES ARE TO BE: 1 DECIMAL PLACE ±0.5, 2 DECIMAL PLACES ±0.3, 3 DECIMAL PLACES ±0.1

3rd ANGLE PROJECTION

ISS/REV	AMENDMENTS	ECO	DRN	CHKD	AUTH	APVD	DATE
B	UPDATED FOR NEW REV GEAR PLATE.	4167	KJS	LSC	RC	DP	20-08-10
C	NOTES UPDATED.	ECS1604	KJS	RC	RC	DP	21-11-11
D	FPI063 AND FPI027 MTG ADDED.	-	KJS	RC	RC	DP	22-1-15

tyco
Fire Protection Products
TYCO FIRE PROTECTION PRODUCTS
17 MARY MULLER DRIVE
P.O. BOX 19545
CHRISTCHURCH, PH: +64 3 3895096
NEW ZEALAND. FAX: +64 3 3895938

MX1
16 WAY RELAY BRD, MX LOOP BRKTS
GEARPLATE POSITIONS

DRAWING No: **1982-71** SHEET **143** of **N**

A3	ISS/REV D	PART No:
-----------	------------------	----------

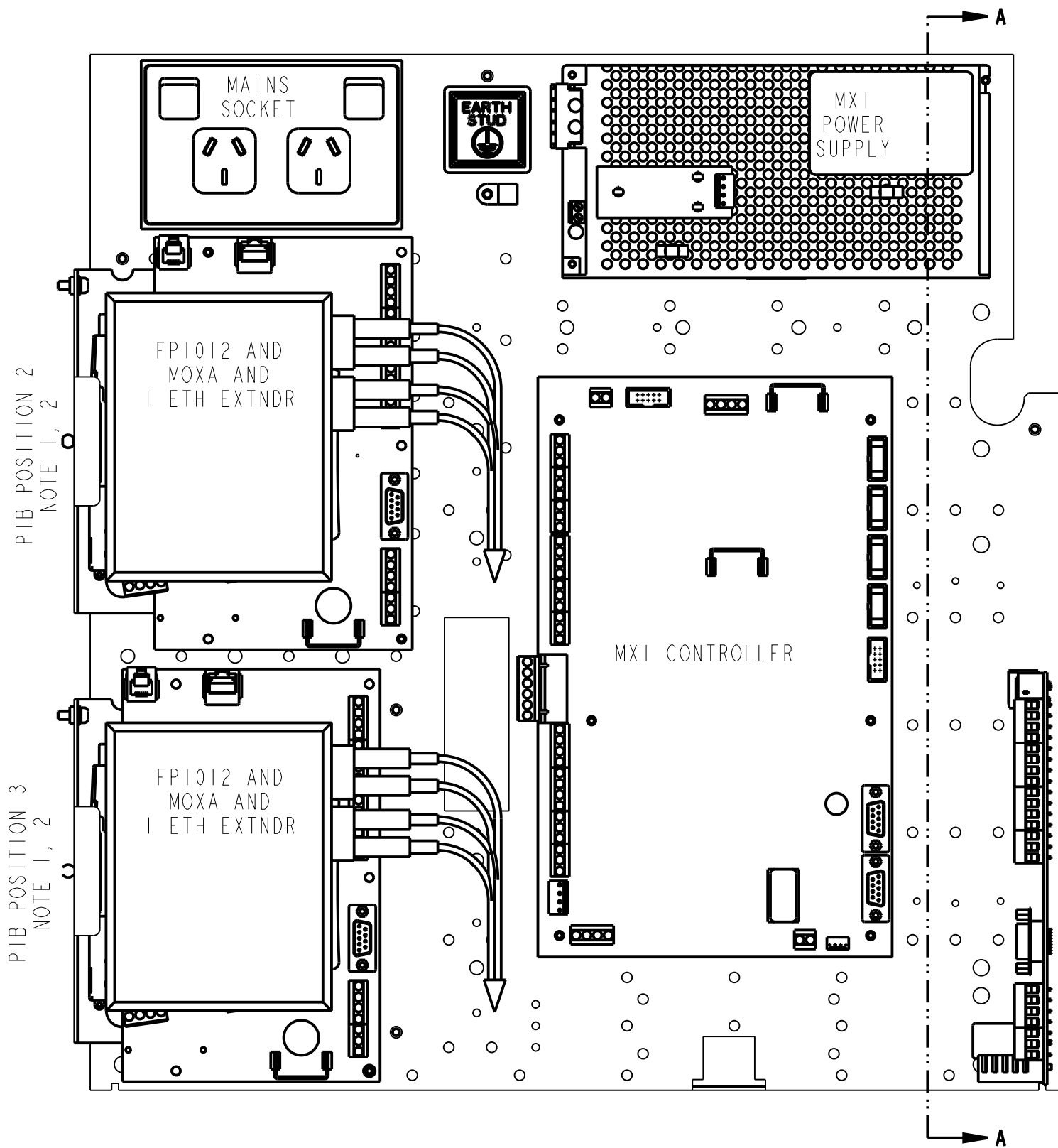

PIB POSITION 2
NOTE 1, 2

PIB POSITION 3
NOTE 1, 2

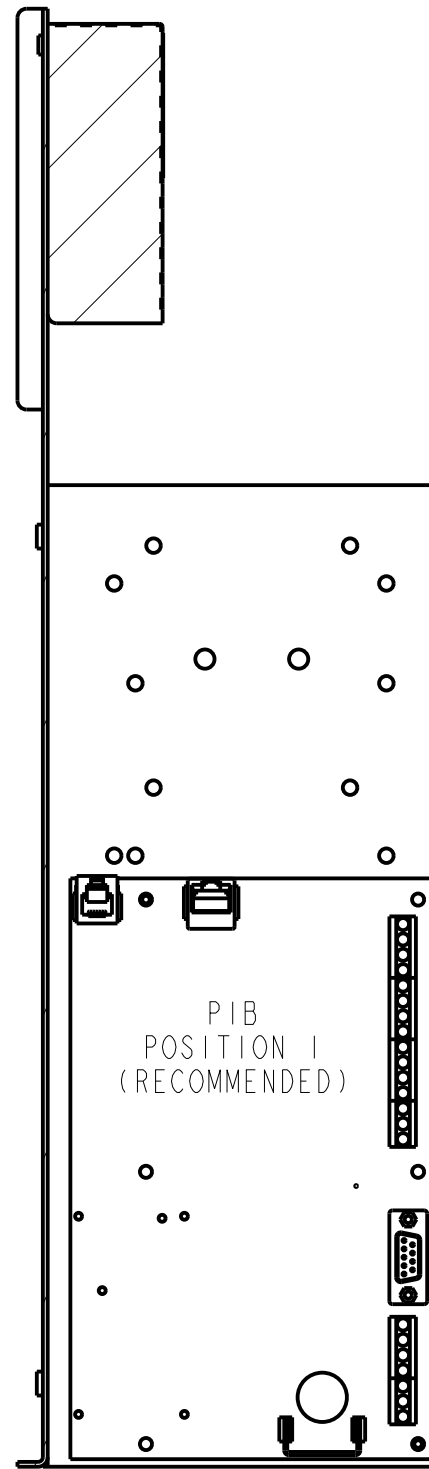

SECTION A-A

NOTES:

1. MOUNT PIB IN POSITION 1 OR 2 USING 2 OFF M3 M/F BARREL NUTS (FA2552) AND 2 OFF M3 X 6 SCREWS (SC0172) FITTED TO J17 AND J19. 4 PLASTIC DOUBLE BARB PCB STAND-OFFS (HW0052) ARE FITTED TO THE 4 REMAINING HOLES. BARREL NUTS AND PLASTIC DOUBLE BARB PCB STAND-OFFS ARE FITTED FROM GEAR PLATE FRONT.

MOUNT PIB IN POSITION 3 (NON-PREFERRED) USING 5 OFF PLASTIC PCB STAND-OFFS PRE-FITTED TO THE GEAR PLATE AND 1 OFF M3 SCREW FITTED TO J17 ON THE BOTTOM RH METAL STAND-OFF.

2. MOUNTING THE PIB IN THE SAME POSITION AS THE FPI012 BRACKET IS A COMPROMISE. ONLY THE MOXA SWITCH OR 1 ETHERNET EXTENDER MAY BE ON THE FPI012 BRACKET, AND THE PIB LEDS ARE NOT VISIBLE.

3. THE MOXA SWITCH AND ETHERNET EXTENDER CLIP ONTO THE DIN RAIL ON THE FPI012 BRACKET. LEAVE A 10mm GAP EACH SIDE OF ETH EXTENDER FOR COOLING. CONNECT THE MOXA EARTH SCREW TO THE GEAR PLATE.

4. REFER TO INSTALLATION INSTRUCTIONS FOR FULL MOUNTING AND EARTHING DETAILS.

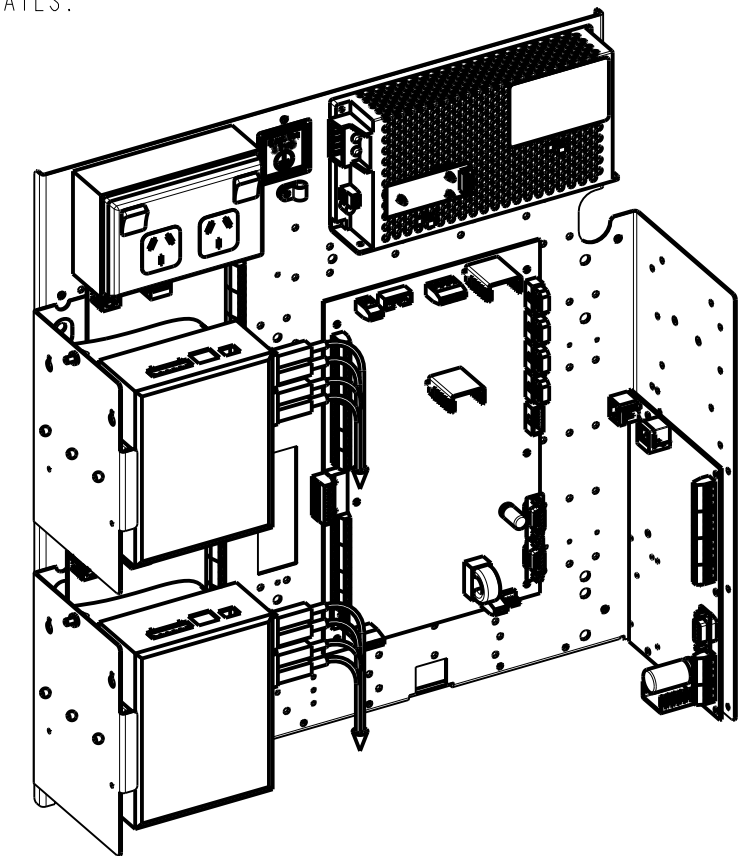

ISOMETRIC VIEW
SCALE 0.200

CONFIDENTIAL. THIS DOCUMENT MUST NOT BE COPIED NOR THE CONTENTS PASSED ON TO ANY THIRD PARTY WITHOUT THE CONSENT OF THE COMPANY.

UNLESS OTHERWISE STATED: ALL DIMENSIONS IN MILLIMETRES. DO NOT SCALE. TOLERANCES ARE TO BE: 1 DECIMAL PLACE ± 0.5 , 2 DECIMAL PLACES ± 0.3 , 3 DECIMAL PLACES ± 0.1

3rd ANGLE PROJECTION

ISS/REV	AMENDMENTS	ECO	DRN	CHKD	AUTH	APVD	DATE
B	UPDATED FOR NEW REV GEAR PLATE.	4167	KJS	LSC	RC	DP	20-08-10
C	NOTES UPDATED, IP NETWORK EQUIP ADDED.	-	KJS	HW	RC	DP	12-4-13

tyco
Fire Protection Products

TYCO FIRE PROTECTION PRODUCTS
17 MARY MULLER DRIVE
P.O. BOX 19545
CHRISTCHURCH, PH: +64 3 3895096
NEW ZEALAND. FAX: +64 3 3895938

**MX1
PIB / IP NETWORK EQUIP
GEARPLATE POSITIONS**

DRAWING No: 1982-71 SHEET 144 of N

A3 ISS/REV C PART No:

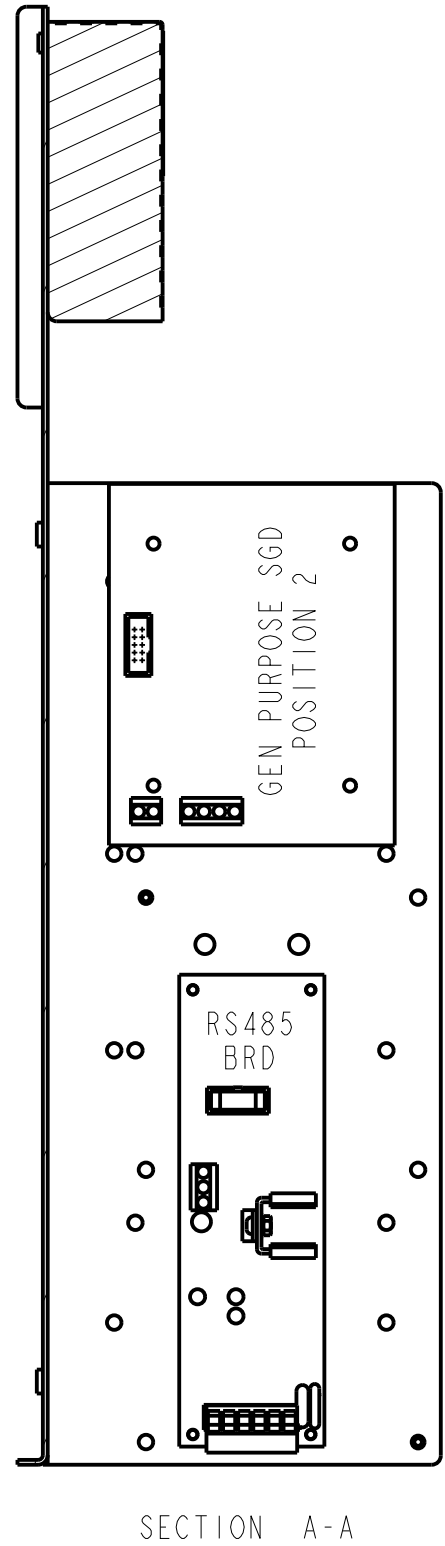
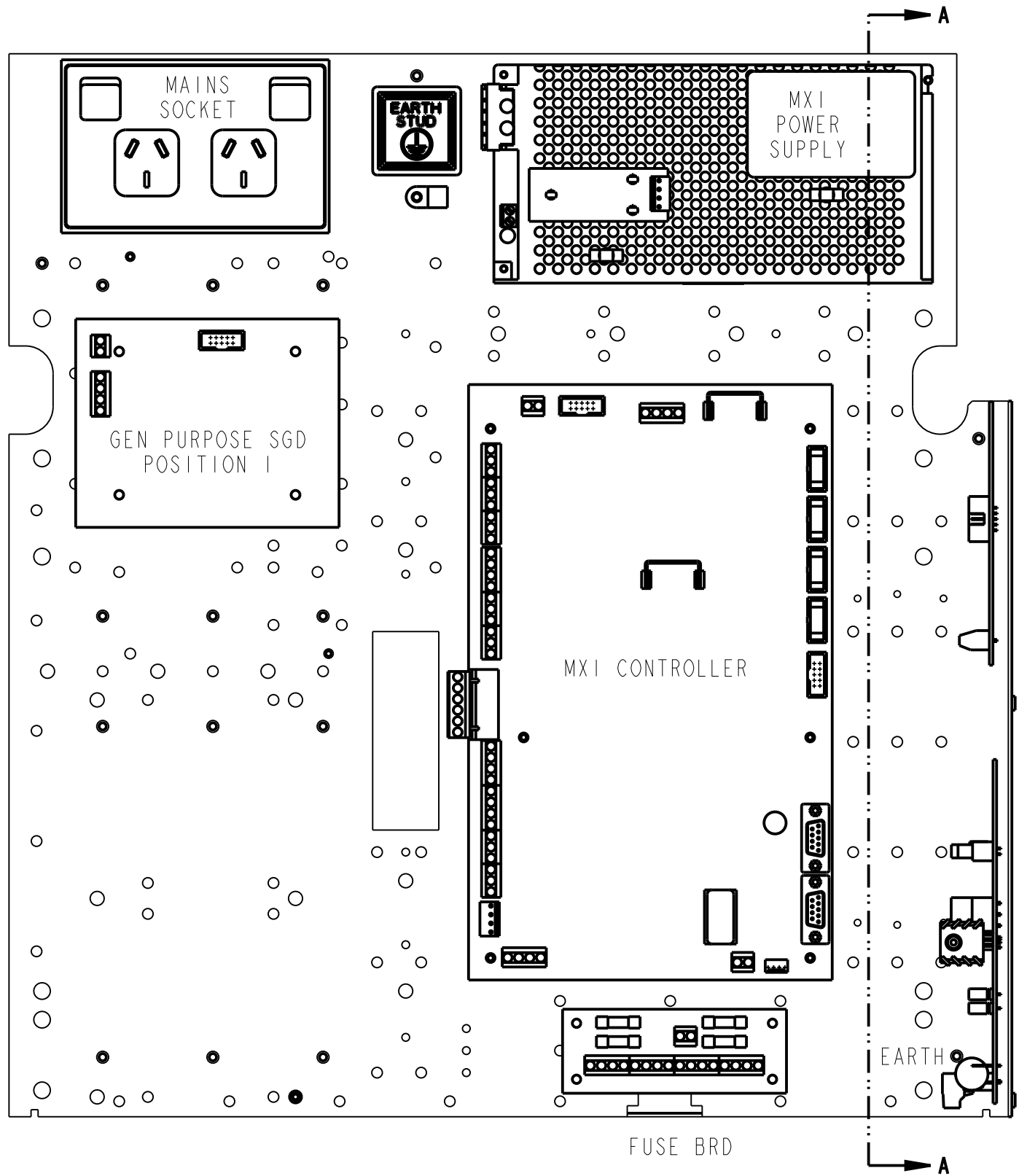

NOTES:

1. MOUNT RS485 BOARD USING 4 PLASTIC DOUBLE BARB PCB STAND-OFFS (HW0303) FITTED FROM GEAR PLATE FRONT. EARTH TO M4 SCREW IN BOTTOM RH CORNER.
2. MOUNT A GENERAL PURPOSE SGD (PA0862) USING 4 PLASTIC DOUBLE BARB PCB STAND-OFFS (HW0053) FITTED FROM GEAR PLATE FRONT.
3. MOUNT FUSE BOARD USING 4 PLASTIC DOUBLE BARB PCB STAND-OFFS (HW0052) FITTED FROM FRONT OF GEAR PLATE.

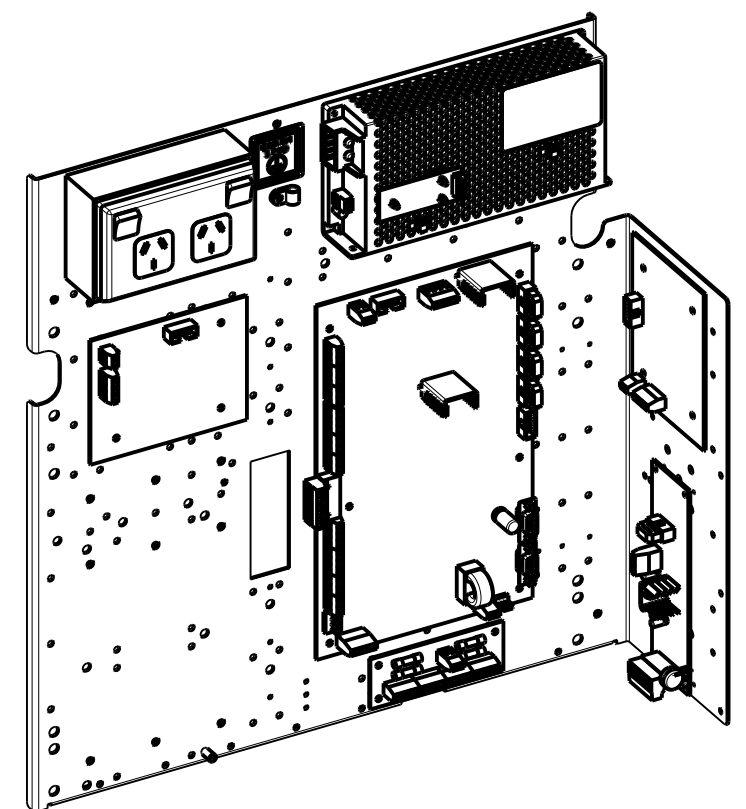

ISOMETRIC VIEW
SCALE 0.200

CONFIDENTIAL THIS DOCUMENT MUST NOT BE COPIED NOR THE CONTENTS PASSED ON TO ANY THIRD PARTY WITHOUT THE CONSENT OF THE COMPANY.

UNLESS OTHERWISE STATED: ALL DIMENSIONS IN MILLIMETRES. DO NOT SCALE. TOLERANCES ARE TO BE: 1 DECIMAL PLACE ±0.5, 2 DECIMAL PLACES ±0.3, 3 DECIMAL PLACES ±0.1

3rd ANGLE PROJECTION

ISS/REV	AMENDMENTS	ECO	DRN	CHKD	AUTH	APVD	DATE
A	ORIGINAL	4167	KJS	LSC	RC	DP	20-08-10
B	SGD IN POSITION 1 ROTATED 180°	ECS1604	KJS	RC	RC	DP	22-11-11
C	FUSE BRD ADDED.	-	KJS	RC	RC	DP	12-4-13

tyco
Fire Protection Products
TYCO FIRE PROTECTION PRODUCTS
17 MARY MULLER DRIVE
P.O. BOX 19545
CHRISTCHURCH, PH: +64 3 3895096
NEW ZEALAND. FAX: +64 3 3895938

MX1
RS485 BRD, SGD, FUSE BRD
GEARPLATE POSITIONS

DRAWING No: **1982-71** SHEET **148** of **N**

A3	ISS/REV C	PART No:
-----------	------------------	----------

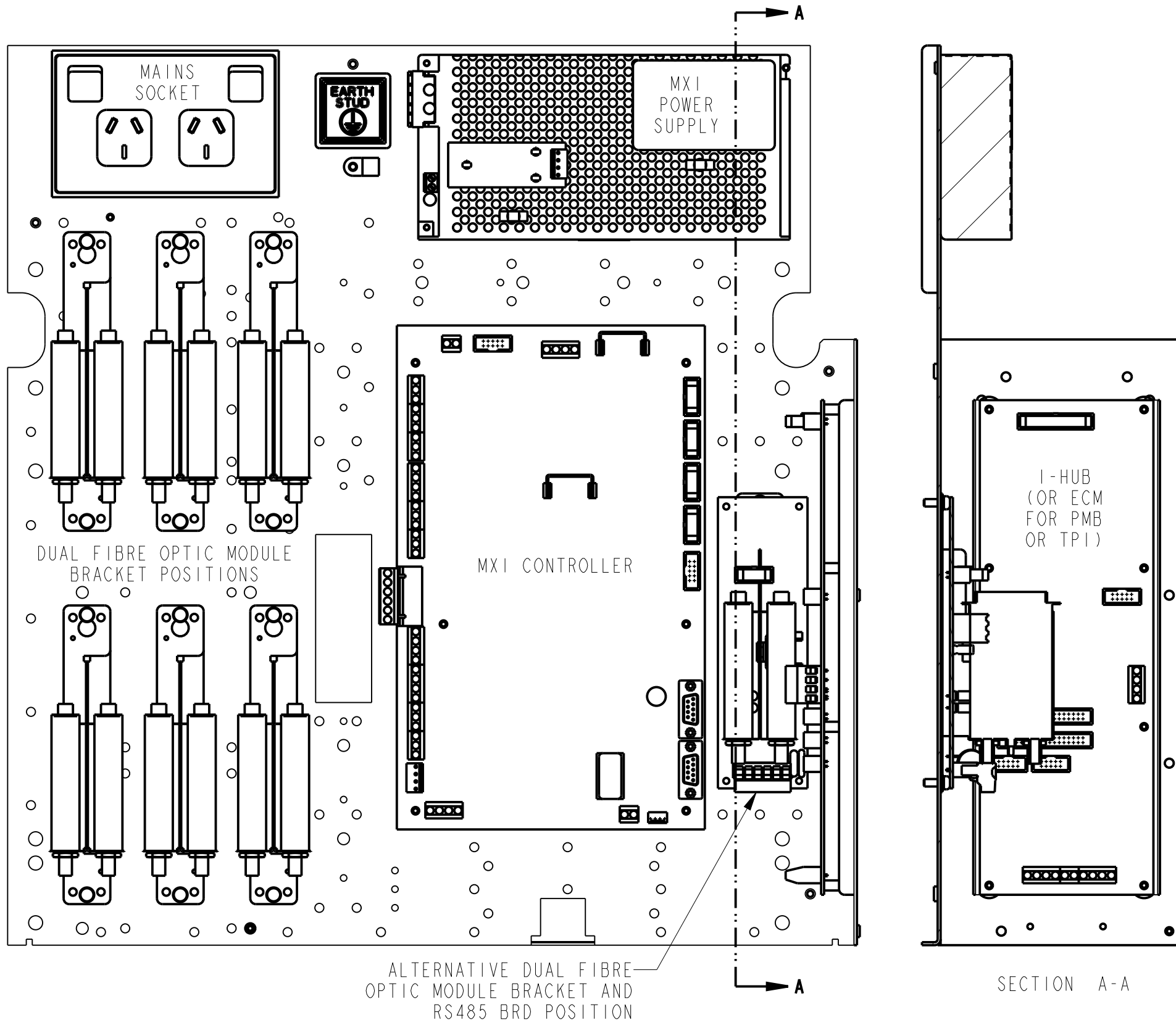

NOTES:

1. MOUNT THE I-HUB ON THE MOUNTING PLATE (FA2083) WITH 8 OFF M3 X 6 SCREWS (SC0172). MOUNT THE ECM MOUNTING PLATE ON THE GEAR PLATE SIDE FOLD USING 4 OFF M4 X 10 SCREWS (SC0176). M4 SCREWS FITTED FROM REAR OF GEAR PLATE SIDE FOLD.
2. MOUNT RS485 BOARD USING 4 PLASTIC DOUBLE BARB PCB STAND-OFFS (HW0303) FITTED FROM GEAR PLATE FRONT. EARTH TO M4 SCREW IN BOTTOM RH CORNER.
3. MOUNT THE DUAL OSDI39 FIBRE OPTIC MODEM MOUNTING BRACKET (FPI032) IN 6 LH POSITIONS WITH 2 OFF M4 X 10 SCREWS (SC0176) SUPPLIED WITH BRACKET. ALTERNATIVELY AN FPI032 CAN BE MOUNTED IN THE RH POSITION WITH 2 OFF PK 6 X 3/8" SCREWS (SC0090) USING 2 OFF Ø3.00 HOLES PROVIDED IN GEAR PLATE.

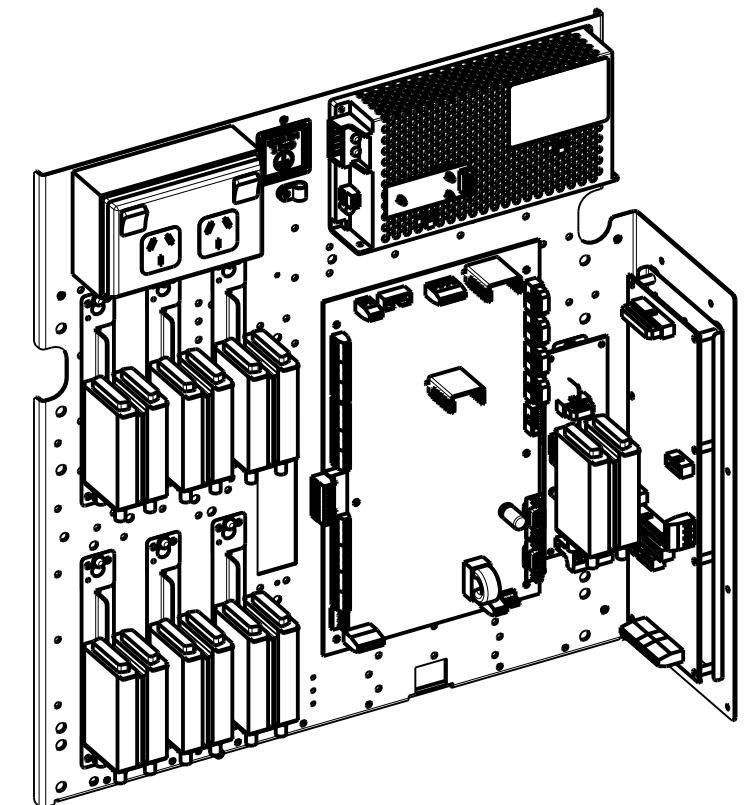

ISOMETRIC VIEW
SCALE 0.200

CONFIDENTIAL. THIS DOCUMENT MUST NOT BE COPIED NOR THE CONTENTS PASSED ON TO ANY THIRD PARTY WITHOUT THE CONSENT OF THE COMPANY.

UNLESS OTHERWISE STATED: ALL DIMENSIONS IN MILLIMETRES. DO NOT SCALE. TOLERANCES ARE TO BE: 1 DECIMAL PLACE ±0.5, 2 DECIMAL PLACES ±0.3, 3 DECIMAL PLACES ±0.1

3rd ANGLE PROJECTION

ISS/REV	AMENDMENTS	ECO	DRN	CHKD	AUTH	APVD	DATE
A	ORIGINAL	4167	KJS	LSC	RC	DP	20-08-10
B	3 X GENERAL PURPOSE RELAY BOARDS ADDED.	4270	KJS	GEL	LSC	DP	19-05-11
C	3 X G P RELAY BRDS REMOVED, 7 X FIBRE OPTIC MODEMS ADDED	-	KJS	HW	RC	DP	11-4-13

tyco
Fire Protection Products

TYCO FIRE PROTECTION PRODUCTS
17 MARY MULLER DRIVE
P.O. BOX 19545
CHRISTCHURCH, PH: +64 3 3895096
NEW ZEALAND. FAX: +64 3 3895938

MX1
I-HUB / FIBRE OPTIC MODEMS
GEARPLATE POSITIONS

DRAWING No: **1982-71** SHEET **149** of **N**

A3	ISS/REV C	PART No:
-----------	------------------	----------

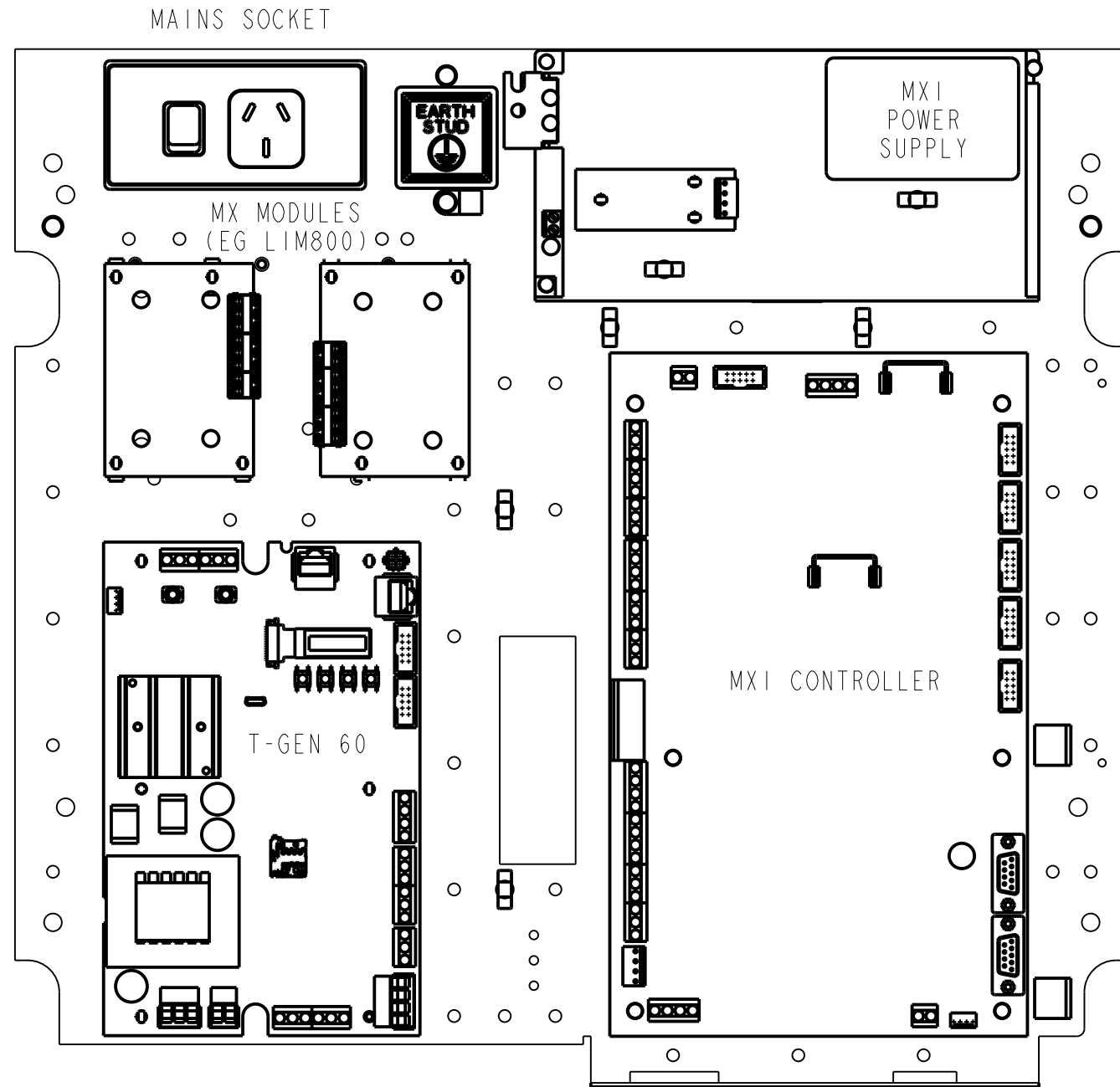

NOTES:

1. MOUNT T-GEN 60 USING 5 PLASTIC STAND-OFFS (HW0130) AND 1 OFF M3 X12 SCREW (SC0177). STAND-OFFS FACTORY FITTED FROM GEAR PLATE REAR.
2. MOUNT MX MODULES USING 4 PLASTIC DOUBLE BARB PCB STAND-OFFS (HW0052) FITTED FROM FRONT OF GEAR PLATE.

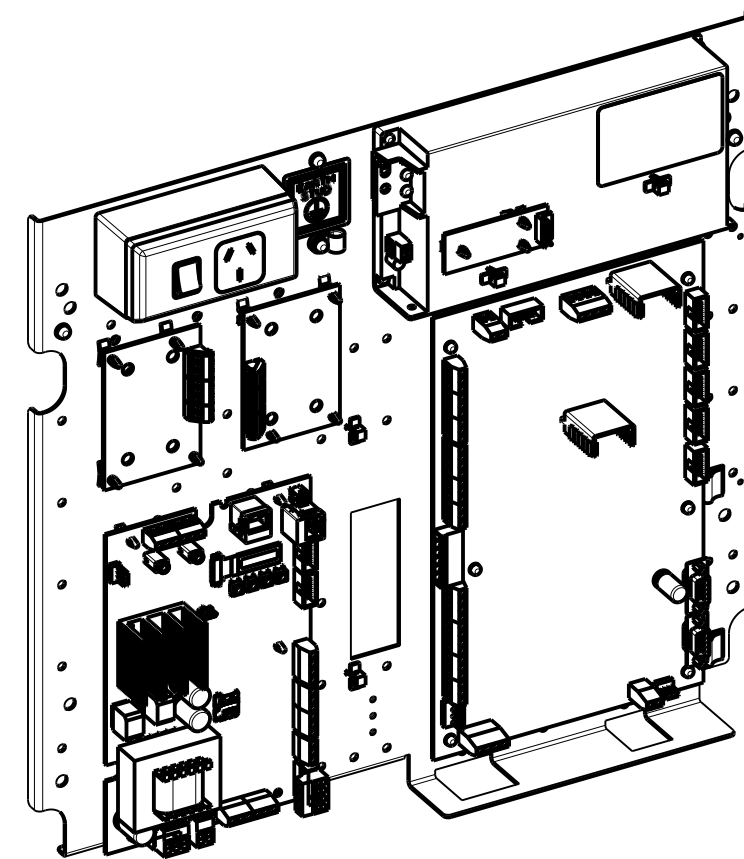

ISOMETRIC VIEW
SCALE 0.250

CONFIDENTIAL. THIS DOCUMENT MUST NOT BE COPIED NOR THE CONTENTS PASSED ON TO ANY THIRD PARTY WITHOUT THE CONSENT OF THE COMPANY.

UNLESS OTHERWISE STATED: ALL DIMENSIONS IN MILLIMETRES. DO NOT SCALE. TOLERANCES ARE TO BE: 1 DECIMAL PLACE ± 0.5 , 2 DECIMAL PLACES ± 0.3 , 3 DECIMAL PLACES ± 0.1

3rd ANGLE PROJECTION

ISS/REV	AMENDMENTS	ECO	DRN	CHKD	AUTH	APVD	DATE
A	ORIGINAL	-	KJS	RC	RC	RC	03-09-13
B	UPDATED FOR T-GEN 60.	5053	KJS	RC	RC	DC	8-9-17

© 2017 Johnson Controls. All rights reserved.
All specifications and other information shown were current as of document revision date and are subject to change without notice.

JOHNSON CONTROLS
17 MARY MULLER DRIVE
P.O. BOX 19545
CHRISTCHURCH, PH: +64 3 3895096
NEW ZEALAND. FAX: +64 3 3895938

**MX1
T-GEN 60, MX MODULES
8U GEARPLATE POSITIONS**

DRAWING No: 1982-71 SHEET 152 of N

A3 ISS/REV B PART No:

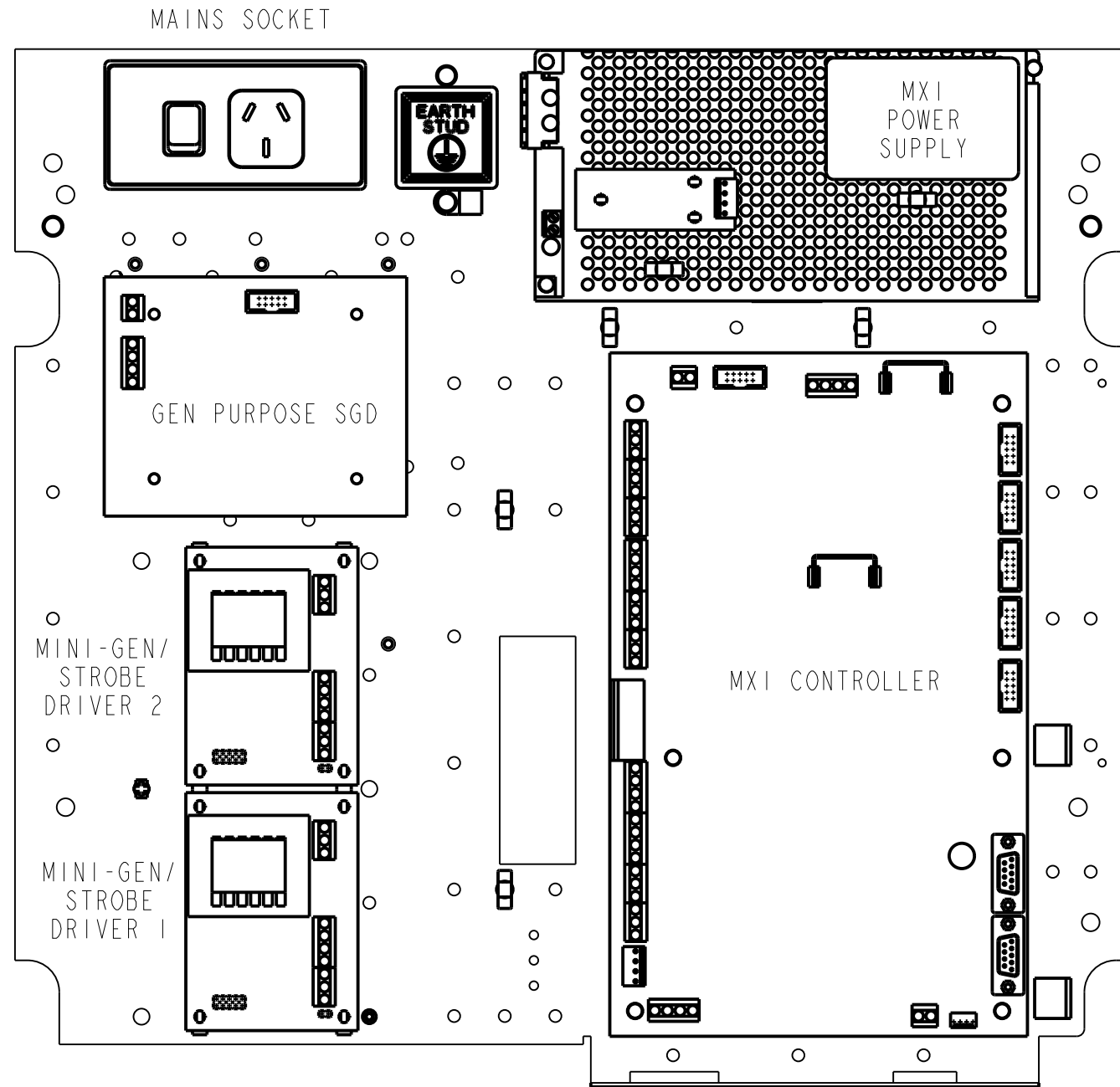

NOTES:

1. MOUNT MINI-GEN OR STROBE DRIVERS USING 4 PLASTIC DOUBLE BARB PCB STAND-OFFS (HW0052) FITTED FROM FRONT OF GEAR PLATE.
2. EARTH MINI-GEN OR STROBE DRIVER TO GEAR PLATE EARTH POINT USING EARTH LEAD, (E.G. LM0231 INCLUDED IN MX1).
3. MOUNT A GENERAL PURPOSE SGD (PA0862) USING 4 PLASTIC DOUBLE BARB PCB STAND-OFFS (HW0053) FITTED FROM GEAR PLATE FRONT.

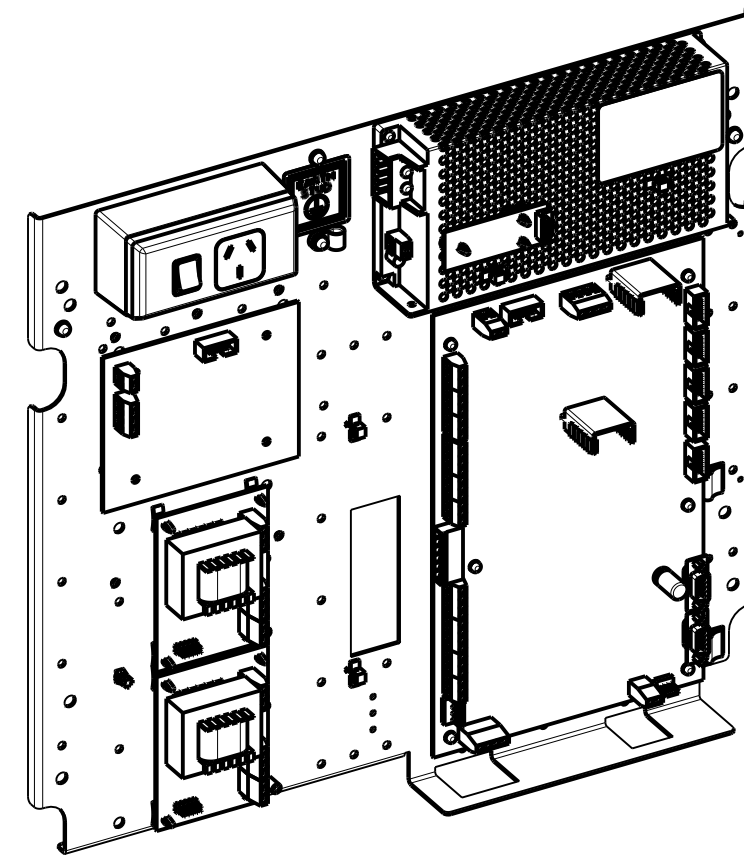

ISOMETRIC VIEW
SCALE 0.250

CONFIDENTIAL THIS DOCUMENT MUST NOT BE COPIED NOR THE CONTENTS PASSED ON TO ANY THIRD PARTY WITHOUT THE CONSENT OF THE COMPANY.

UNLESS OTHERWISE STATED: ALL DIMENSIONS IN MILLIMETRES. DO NOT SCALE. TOLERANCES ARE TO BE: 1 DECIMAL PLACE ± 0.5 , 2 DECIMAL PLACES ± 0.3 , 3 DECIMAL PLACES ± 0.1

3rd ANGLE PROJECTION

ISS/REV	AMENDMENTS	ECO	DRN	CHKD	AUTH	APVD	DATE
A	ORIGINAL	-	KJS	RC	RC	DP	03-09-13
B	NOTE 1 UPDATED. MINI-GENS MOVED 10mm TO LEFT.	4570	KJS	GEL	LSC	DP	2-12-13

tyco
Fire Protection Products
TYCO FIRE PROTECTION PRODUCTS
17 MARY MULLER DRIVE
P.O. BOX 19545
CHRISTCHURCH, PH: +64 3 3895096
NEW ZEALAND. FAX: +64 3 3895938

MX1
SGD, MINI-GEN / STROBE
8U GEARPLATE POSITIONS

DRAWING No: **1982-71** SHEET **153** of **N**

A3	ISS/REV B	PART No:
-----------	------------------	----------

MAINS SOCKET

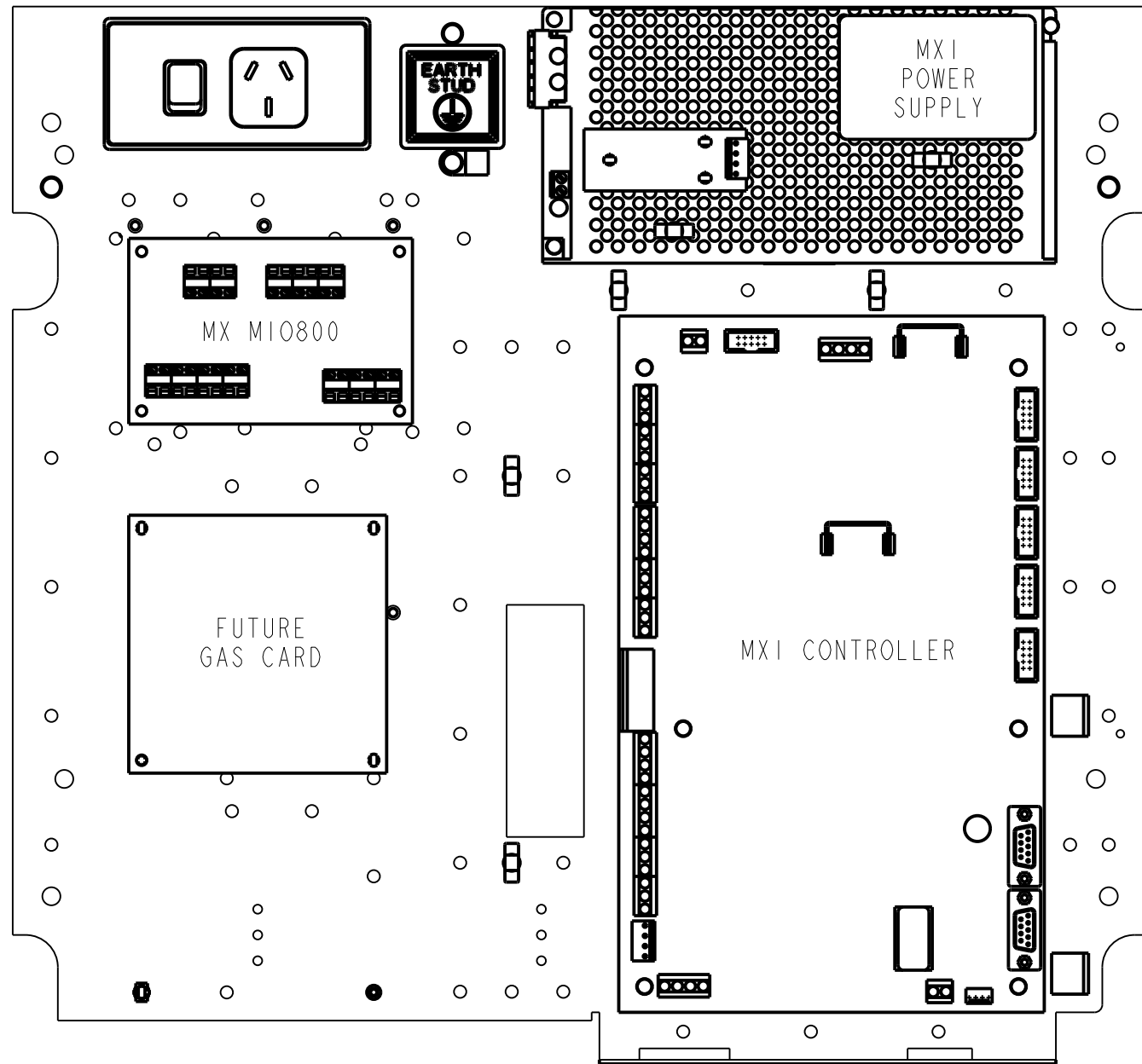

NOTES:

1. MOUNT MX MIO800 MODULE USING 4 PLASTIC DOUBLE BARB PCB STAND-OFFS (HW0052) FITTED FROM FRONT OF GEAR PLATE.
2. HOLES PROVIDED FOR MOUNTING THE FUTURE GAS CARD USING 4 PLASTIC DOUBLE BARB PCB STAND-OFFS (HW0052) FITTED FROM FRONT OF GEAR PLATE.

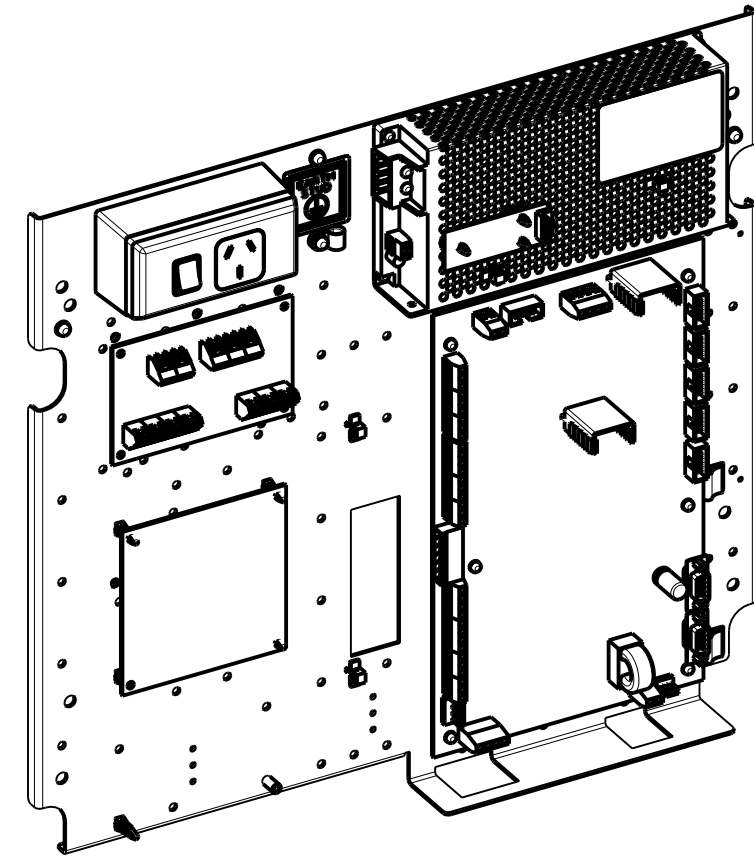

ISOMETRIC VIEW
SCALE 0.250

CONFIDENTIAL. THIS DOCUMENT MUST NOT BE COPIED NOR THE CONTENTS PASSED ON TO ANY THIRD PARTY WITHOUT THE CONSENT OF THE COMPANY.

UNLESS OTHERWISE STATED: ALL DIMENSIONS IN MILLIMETRES. DO NOT SCALE. TOLERANCES ARE TO BE: 1 DECIMAL PLACE ± 0.5 , 2 DECIMAL PLACES ± 0.3 , 3 DECIMAL PLACES ± 0.1

3rd ANGLE PROJECTION

ISS/REV	AMENDMENTS	ECO	DRN	CHKD	AUTH	APVD	DATE
A	ORIGINAL	-	KJS	RC	RC	DP	03-09-13

tyco
Fire Protection Products

TYCO FIRE PROTECTION PRODUCTS
17 MARY MULLER DRIVE
P.O. BOX 19545
CHRISTCHURCH, PH: +64 3 3895096
NEW ZEALAND. FAX: +64 3 3895938

MX1
MIO800, FUTURE GAS CARD
8U GEARPLATE POSITIONS

DRAWING No: 1982-71 SHEET 154 of N

A3 ISS/REV A PART No:

NOTES:

1. MOUNT GENERAL PURPOSE RELAY BOARDS (PA0730) USING 4 PLASTIC DOUBLE BARB PCB STAND-OFFS (HW0052) PER BOARD, FITTED FROM FRONT OF GEAR PLATE.

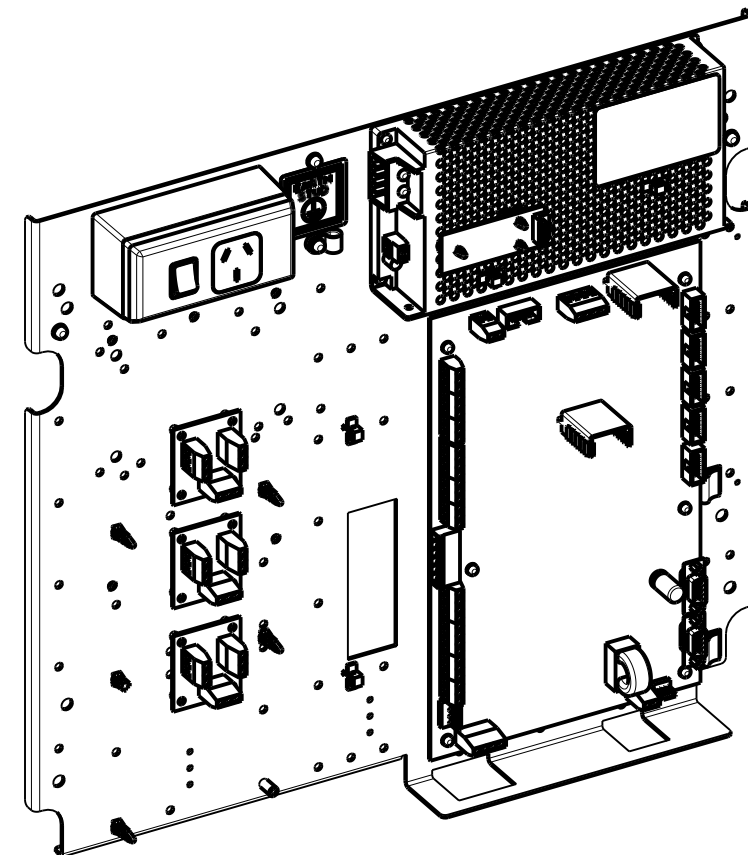
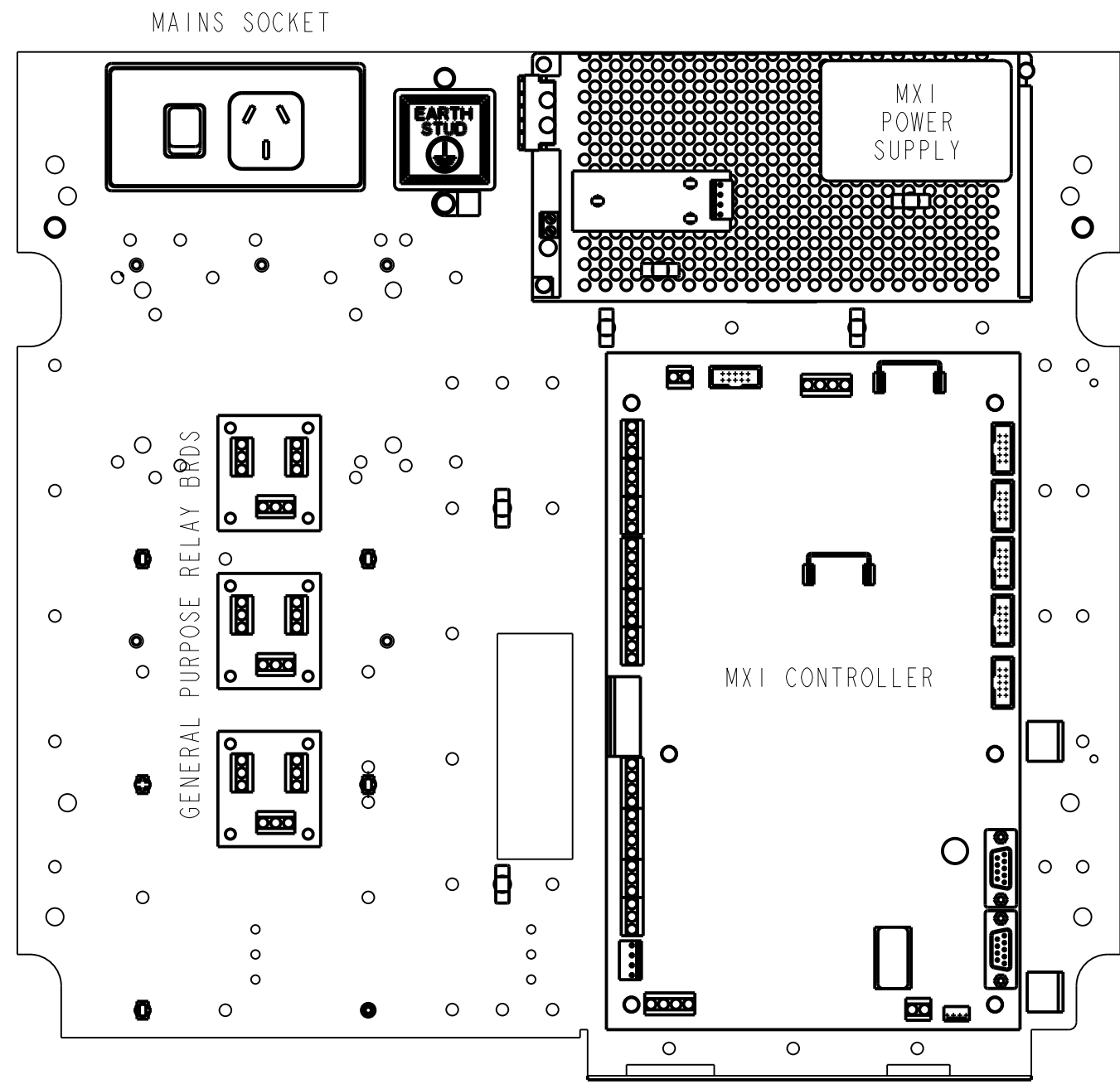

ISOMETRIC VIEW
SCALE 0.250

CONFIDENTIAL. THIS DOCUMENT MUST NOT BE COPIED NOR THE CONTENTS PASSED ON TO ANY THIRD PARTY WITHOUT THE CONSENT OF THE COMPANY.

UNLESS OTHERWISE STATED: ALL DIMENSIONS IN MILLIMETRES. DO NOT SCALE. TOLERANCES ARE TO BE: 1 DECIMAL PLACE ± 0.5 , 2 DECIMAL PLACES ± 0.3 , 3 DECIMAL PLACES ± 0.1

3rd ANGLE PROJECTION

ISS/REV	AMENDMENTS	ECO	DRN	CHKD	AUTH	APVD	DATE
A	ORIGINAL	-	KJS	RC	RC	DP	03-09-13

tyco
Fire Protection Products
TYCO FIRE PROTECTION PRODUCTS
17 MARY MULLER DRIVE
P.O. BOX 19545
CHRISTCHURCH, PH: +64 3 3895096
NEW ZEALAND. FAX: +64 3 3895938

**MX1
GEN PURPOSE RELAY
8U GEARPLATE POSITIONS**

DRAWING No: **1982-71** SHEET **155** of **N**

A3	ISS/REV A	PART No:
-----------	------------------	----------

NOTES:

1. MOUNT MX1 LOOP CARD USING 4 PLASTIC DOUBLE BARB PCB STAND-OFFS (HW0052) FITTED FROM FRONT OF GEAR PLATE.

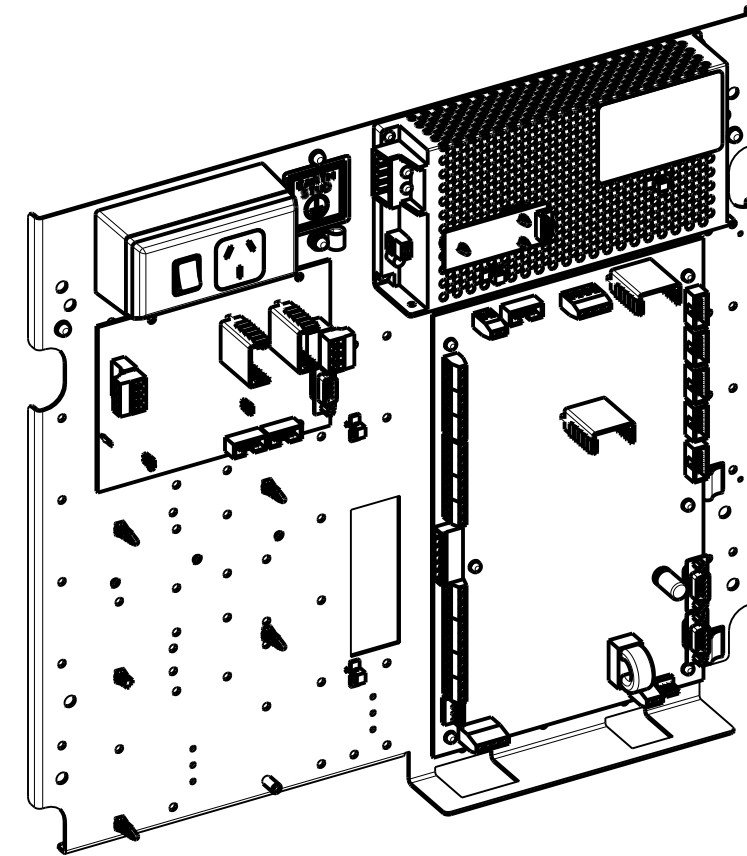
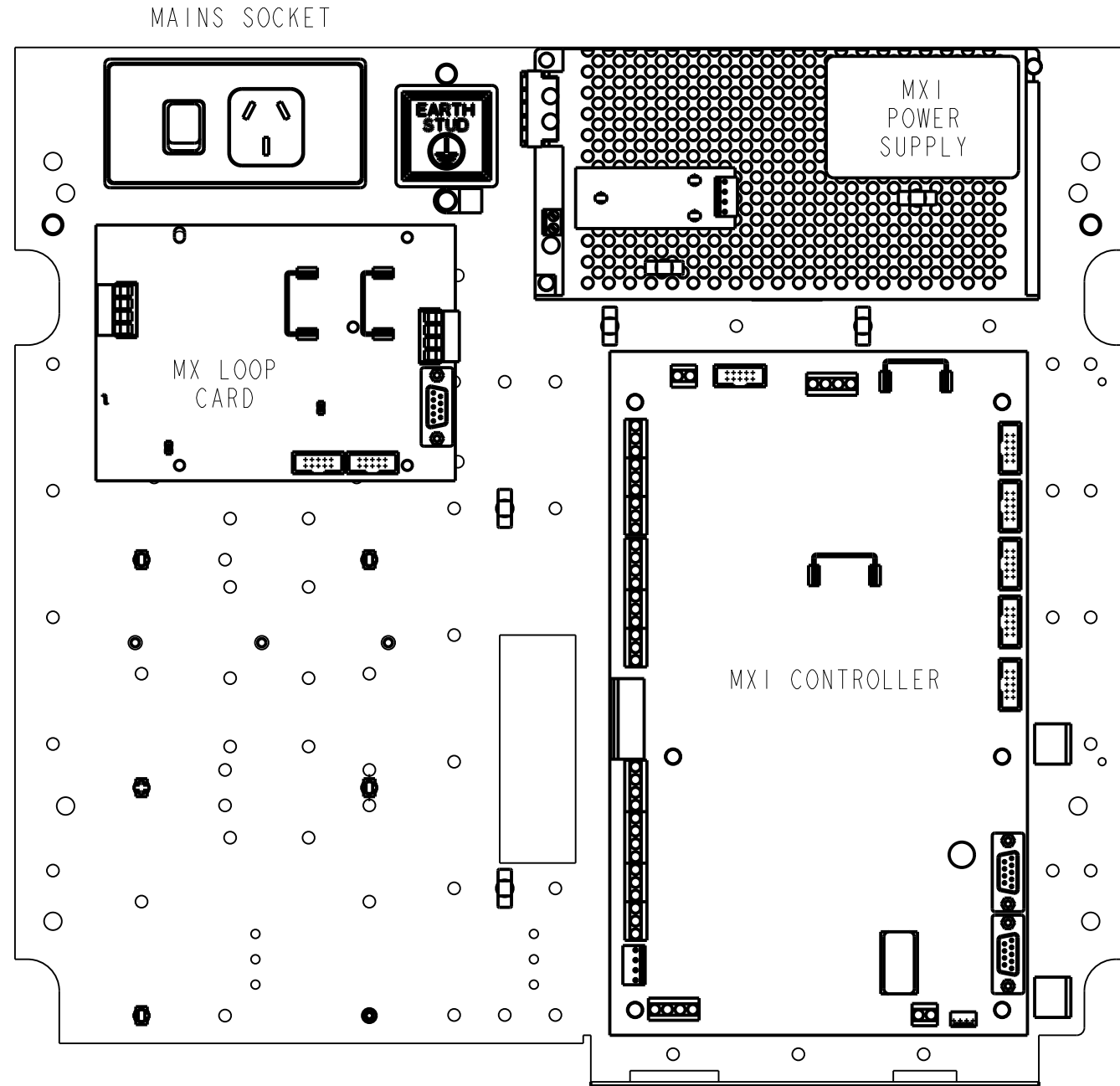

ISOMETRIC VIEW
SCALE 0.250

CONFIDENTIAL. THIS DOCUMENT MUST NOT BE COPIED NOR THE CONTENTS PASSED ON TO ANY THIRD PARTY WITHOUT THE CONSENT OF THE COMPANY.

UNLESS OTHERWISE STATED: ALL DIMENSIONS IN MILLIMETRES. DO NOT SCALE. TOLERANCES ARE TO BE: 1 DECIMAL PLACE ± 0.5 , 2 DECIMAL PLACES ± 0.3 , 3 DECIMAL PLACES ± 0.1

3rd ANGLE PROJECTION

ISS/REV	AMENDMENTS	ECO	DRN	CHKD	AUTH	APVD	DATE
A	ORIGINAL	-	KJS	RC	RC	DP	03-09-13

tyco
Fire Protection Products

TYCO FIRE PROTECTION PRODUCTS
17 MARY MULLER DRIVE
P.O. BOX 19545
CHRISTCHURCH, PH: +64 3 3895096
NEW ZEALAND. FAX: +64 3 3895938

MX1
MX LOOP CARD
8U GEARPLATE POSITIONS

DRAWING No: 1982-71 SHEET 156 of N

A3 ISS/REV A PART No:

NOTES:

1. MOUNT EACH BRACKET (FPI044, FP0950, FPI027) WITH 2 OFF M4 X 10 SCREWS (SC0176). SCREWS FITTED FROM GEAR PLATE FRONT.
2. MOUNT MX MODULES ON FPI027 BRACKET USING 4 PLASTIC PCB STAND-OFFS (HW0131) PROVIDED WITH BRACKET.
3. MOUNT MINI-GEN OR STROBE DRIVER USING 4 PLASTIC DOUBLE BARB PCB STAND-OFFS (HW0052) FITTED FROM FRONT OF GEAR PLATE.
4. EARTH EACH MINI-GEN OR STROBE DRIVER TO A GEAR PLATE EARTH POINT USING EARTH LEAD, (E.G. LM0231 INCLUDED IN MX1).

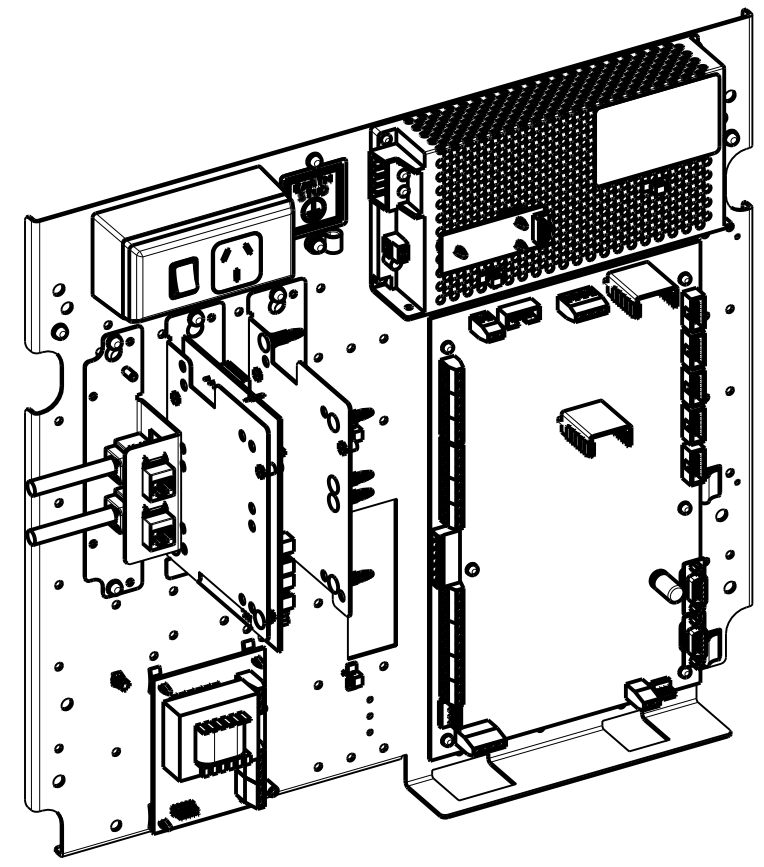
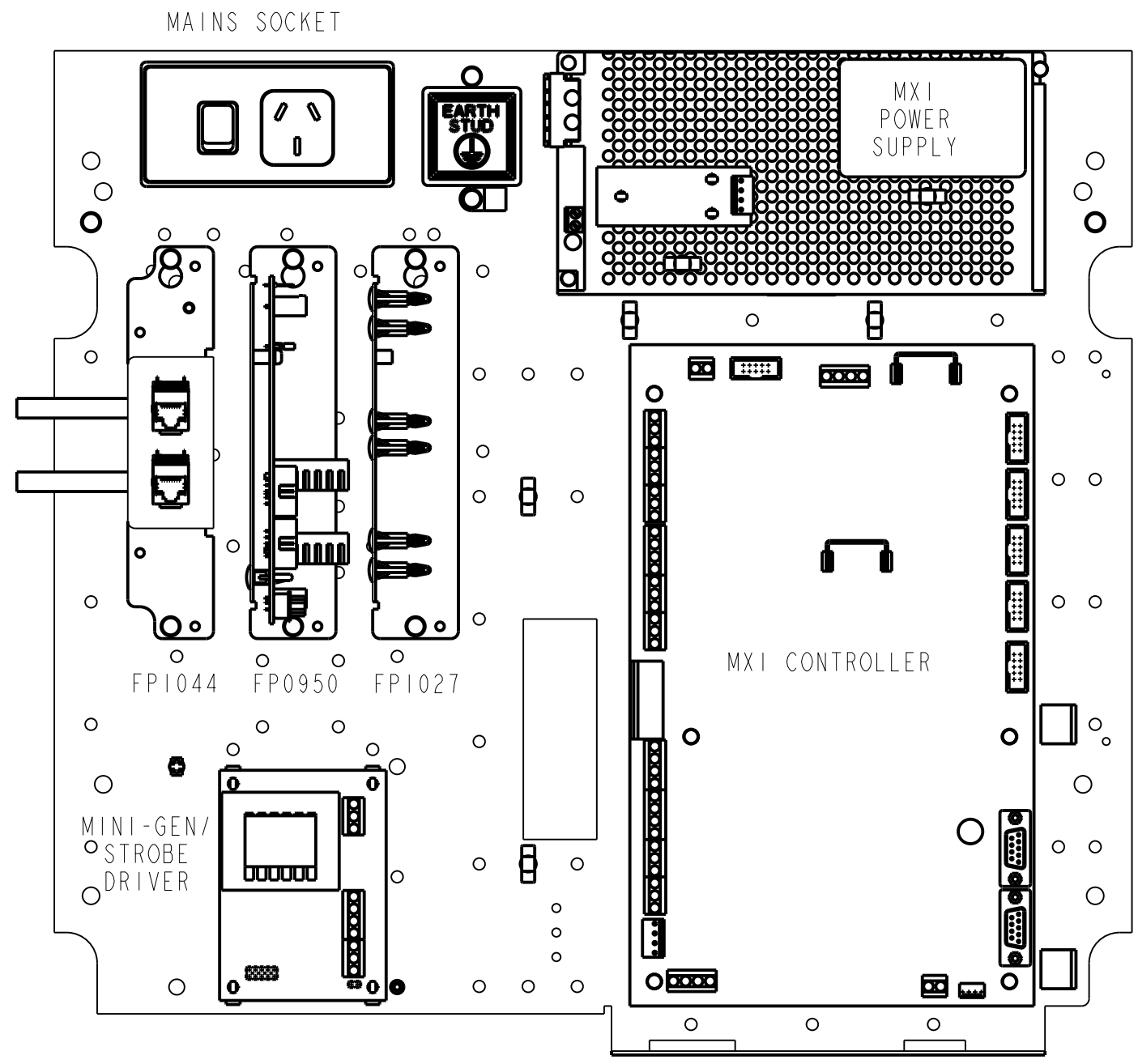

ISOMETRIC VIEW
SCALE 0.250

CONFIDENTIAL. THIS DOCUMENT MUST NOT BE COPIED NOR THE CONTENTS PASSED ON TO ANY THIRD PARTY WITHOUT THE CONSENT OF THE COMPANY.

UNLESS OTHERWISE STATED: ALL DIMENSIONS IN MILLIMETRES. DO NOT SCALE. TOLERANCES ARE TO BE: 1 DECIMAL PLACE ±0.5, 2 DECIMAL PLACES ±0.3, 3 DECIMAL PLACES ±0.1

3rd ANGLE PROJECTION

ISS/REV	AMENDMENTS	ECO	DRN	CHKD	AUTH	APVD	DATE
A	ORIGINAL	-	KJS	RC	RC	DP	03-09-13
B	NOTE 3 UPDATED. MINI-GEN MOVED 10mm TO LEFT.	4570	KJS	GEL	LSC	DP	3-12-13

tyco
Fire Protection Products
TYCO FIRE PROTECTION PRODUCTS
17 MARY MULLER DRIVE
P.O. BOX 19545
CHRISTCHURCH, PH: +64 3 3895096
NEW ZEALAND. FAX: +64 3 3895938

MX1
STP BKT, LOOP CD BKT, MX MOD
8U GEARPLATE POSITIONS

DRAWING No: **1982-71** SHEET **157** of **N**

A3	ISS/REV B	PART No:
-----------	------------------	----------

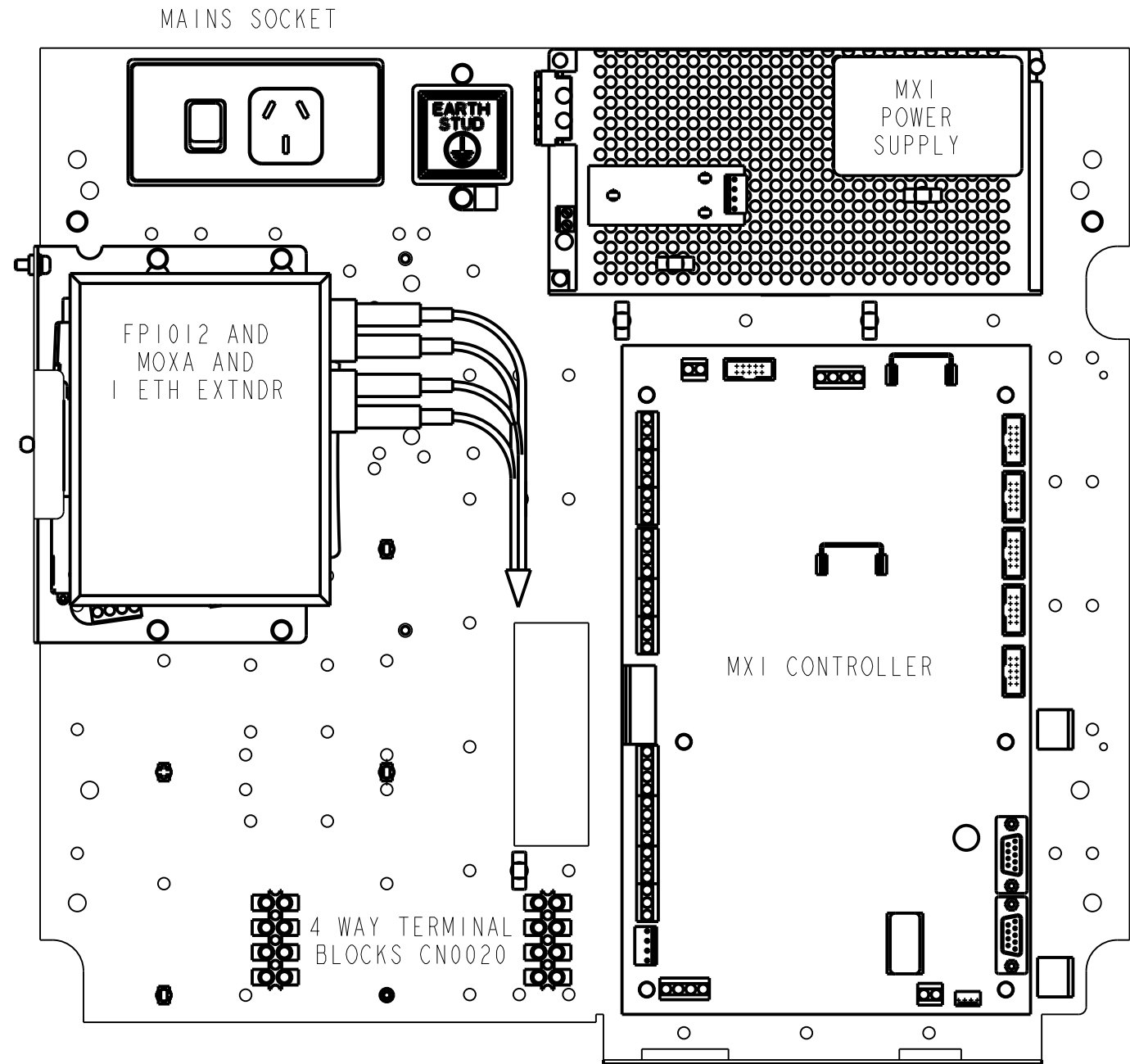

NOTES:

1. MOUNT THE FPI012 BRACKET TO THE GEAR PLATE WITH 4 OFF M4 X 10 SCREWS (SC0176). SCREWS FITTED FROM GEAR PLATE FRONT.
2. THE MOXA SWITCH AND ETHERNET EXTENDER CLIP ONTO THE DIN RAIL ON THE FPI012 BRACKET. MOUNT MOXA CLOSEST TO GEAR PLATE. LEAVE A 10mm GAP EACH SIDE OF ETH EXTENDER FOR COOLING. CONNECT THE MOXA EARTH SCREW TO THE BRACKET.
3. MOUNT THE 4 WAY TERMINAL BLOCKS CN0020 WITH 2 X 1/8" POP RIVETS HW0211.

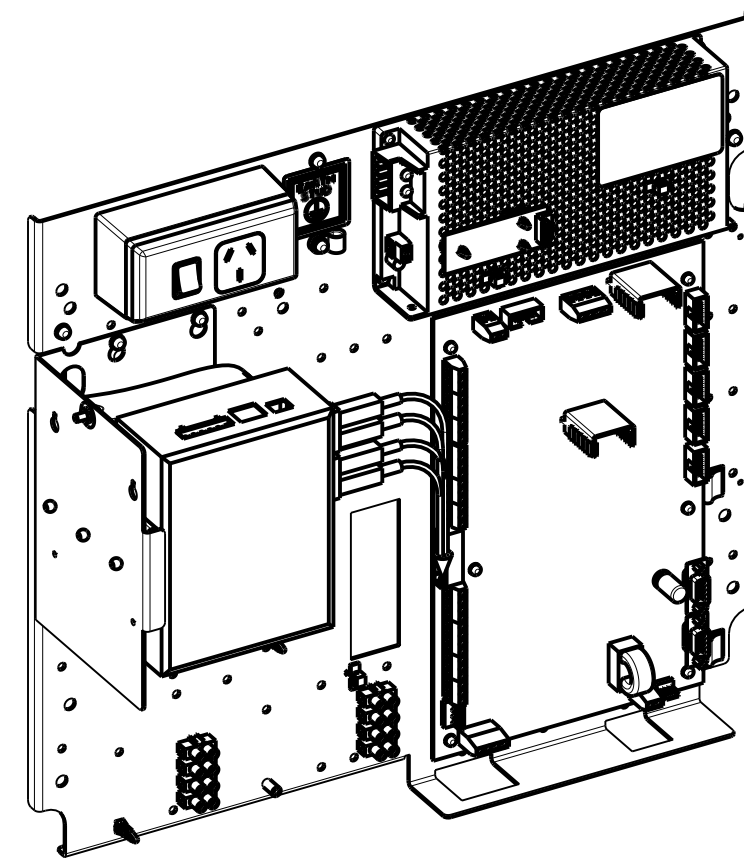

ISOMETRIC VIEW
SCALE 0.250

CONFIDENTIAL THIS DOCUMENT MUST NOT BE COPIED NOR THE CONTENTS PASSED ON TO ANY THIRD PARTY WITHOUT THE CONSENT OF THE COMPANY.

UNLESS OTHERWISE STATED: ALL DIMENSIONS IN MILLIMETRES. DO NOT SCALE. TOLERANCES ARE TO BE: 1 DECIMAL PLACE ± 0.5 , 2 DECIMAL PLACES ± 0.3 , 3 DECIMAL PLACES ± 0.1

3rd ANGLE PROJECTION

ISS/REV	AMENDMENTS	ECO	DRN	CHKD	AUTH	APVD	DATE
A	ORIGINAL	-	KJS	RC	RC	DP	03-09-13

tyco
Fire Protection Products
TYCO FIRE PROTECTION PRODUCTS
17 MARY MULLER DRIVE
P.O. BOX 19545
CHRISTCHURCH, PH: +64 3 3895096
NEW ZEALAND. FAX: +64 3 3895938

**MX1
FP1012, MOXA & EXTENDER
8U GEARPLATE POSITIONS**

DRAWING No: **1982-71** SHEET **158** of **N**

A3	ISS/REV A	PART No:
-----------	------------------	----------

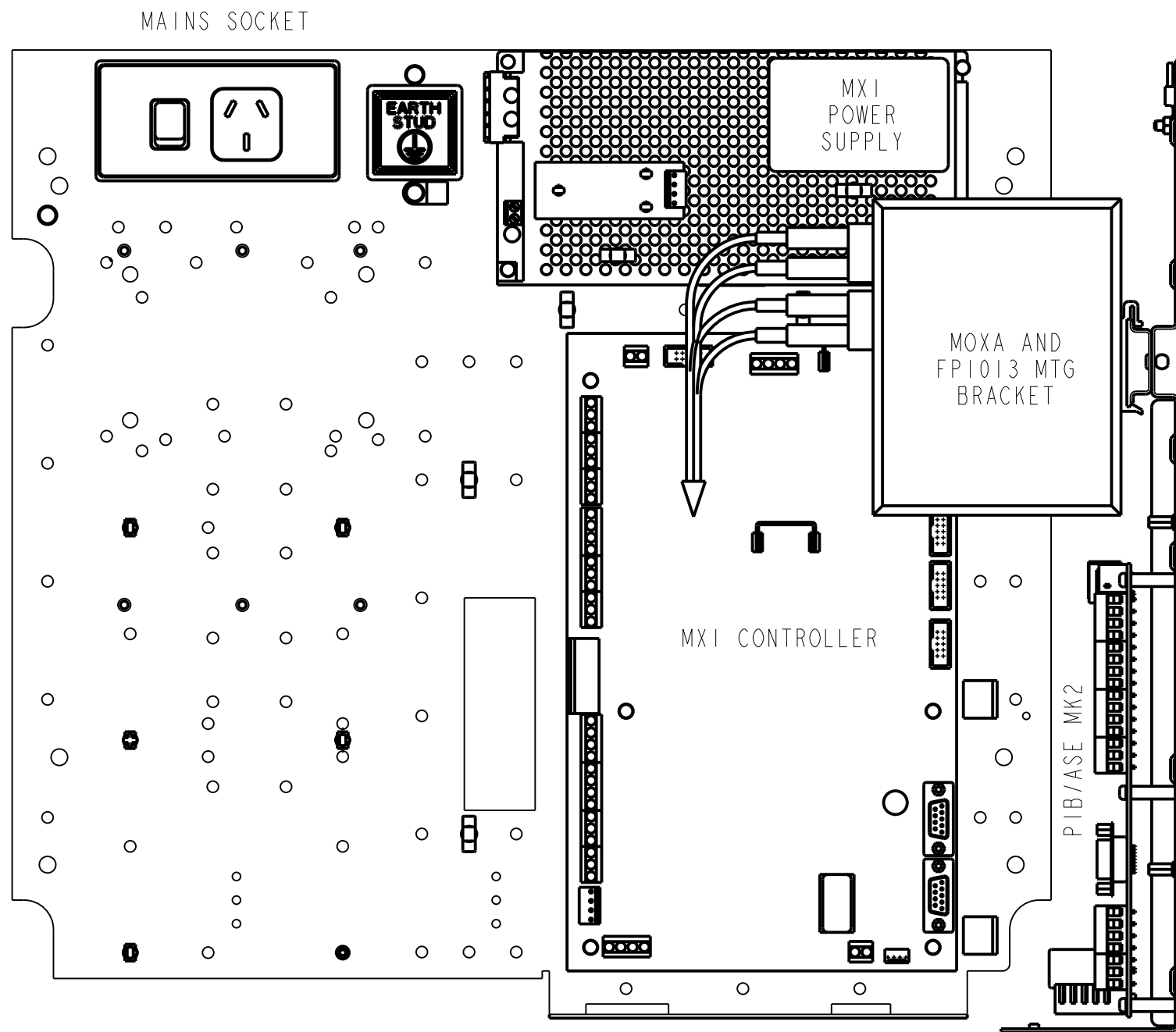

NOTES:

1. MOUNT THE IP NETWORKING BRACKET (FPI013) ON THE 8U CABINET RHS WALL 4 OFF M3 X 12 STUDS USING 4 OFF M3 X 10 BARREL NUTS (FA2016), M3 FLAT WASHERS (WA0005) AND M3 SHAKEPROOF WASHERS (WA0010).
2. ONLY A MOXA SWITCH CAN CLIP ONTO THE DIN RAIL ON THE FPI013 BRACKET. THERE IS INSUFFICIENT ROOM TO MOUNT AN ETHERNET EXTENDER. CONNECT THE MOXA EARTH SCREW TO THE BRACKET.
3. MOUNT THE PIB ON THE FPI013 BRACKET USING 6 OFF M3 X 6 SCREWS (SC0172)
4. ALL FASTENING HARDWARE IS SUPPLIED WITH FPI013.

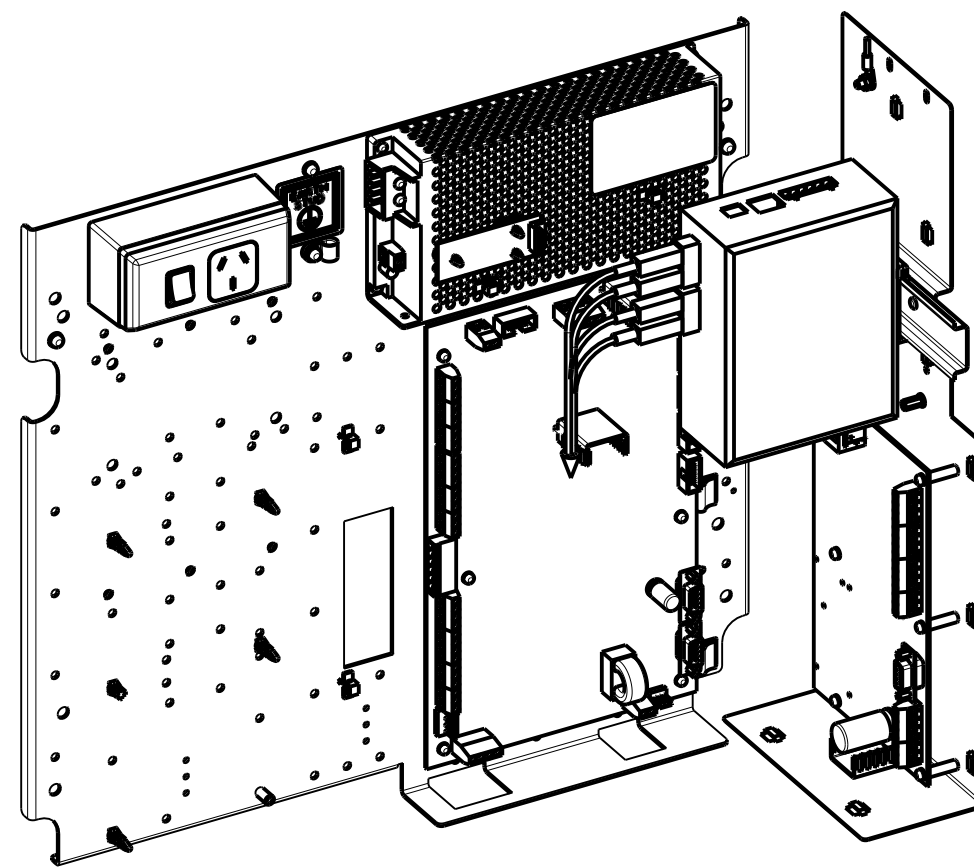

ISOMETRIC VIEW
SCALE 0.250

CONFIDENTIAL. THIS DOCUMENT MUST NOT BE COPIED NOR THE CONTENTS PASSED ON TO ANY THIRD PARTY WITHOUT THE CONSENT OF THE COMPANY.

UNLESS OTHERWISE STATED: ALL DIMENSIONS IN MILLIMETRES. DO NOT SCALE. TOLERANCES ARE TO BE: 1 DECIMAL PLACE ±0.5, 2 DECIMAL PLACES ±0.3, 3 DECIMAL PLACES ±0.1

3rd ANGLE PROJECTION

ISS/REV	AMENDMENTS	ECO	DRN	CHKD	AUTH	APVD	DATE
A	ORIGINAL	-	KJS	RC	RC	RC	03-09-13

tyco
Fire Protection Products
TYCO FIRE PROTECTION PRODUCTS
17 MARY MULLER DRIVE
P.O. BOX 19545
CHRISTCHURCH, PH: +64 3 3895096
NEW ZEALAND. FAX: +64 3 3895938

**MX1
FP1013, MOXA & EXTENDER
8U GEARPLATE POSITIONS**

DRAWING No: **1982-71** SHEET **159** of **N**

A3	ISS/REV A	PART No:
-----------	------------------	----------

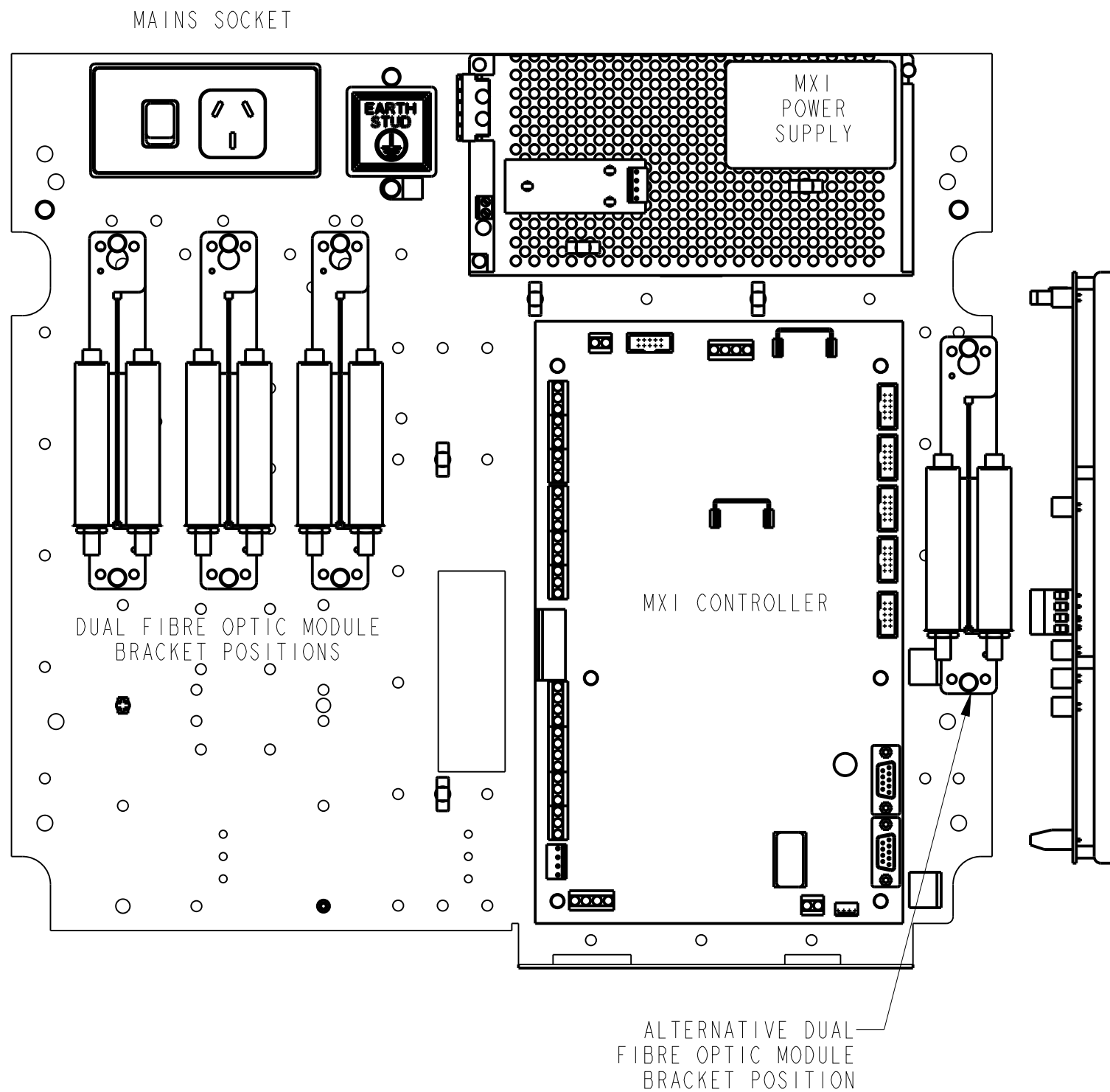

NOTES:

1. MOUNT THE ECM MOUNTING PLATE (FA2083) ON THE 8U CABINET RHS WALL 4 OFF M3 X 12 STUDS USING 4 OFF M3 X 10 BARREL NUTS (FA2016), M3 FLAT WASHERS (WA0005) AND M3 SHAKEPROOF WASHERS (WA0010). REMOUNT THE I-HUB ON THE MOUNTING PLATE (FA2083) WITH 8 OFF M3 X 6 SCREWS (SC0172).

2. MOUNT THE DUAL OSD139 FIBRE OPTIC MODEM MOUNTING BRACKET (FPI032) IN 3 LH POSITIONS WITH 2 OFF M4 X 10 SCREWS (SC0176) SUPPLIED WITH BRACKET.

ALTERNATIVELY AN FPI032 CAN BE MOUNTED IN THE RH POSITION WITH 2 OFF PK 6 X 3/8" SCREWS (SC0090) USING 2 OFF Ø3.00 HOLES PROVIDED IN THE GEAR PLATE.

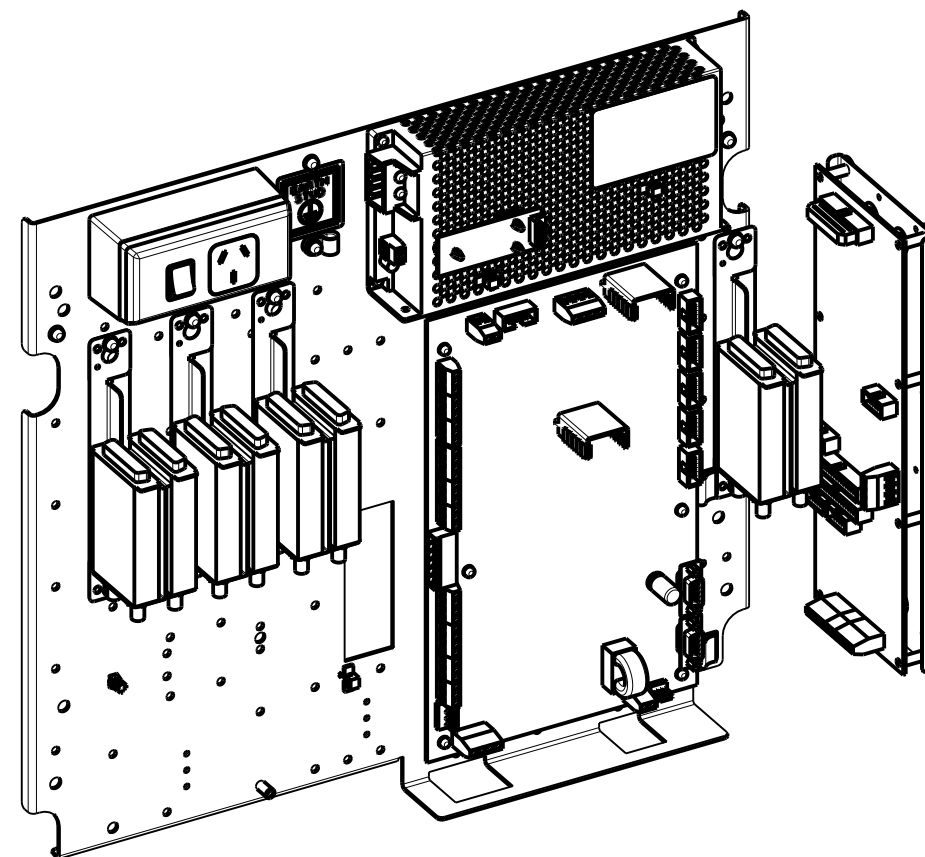

ISOMETRIC VIEW
SCALE 0.250

CONFIDENTIAL THIS DOCUMENT MUST NOT BE COPIED NOR THE CONTENTS PASSED ON TO ANY THIRD PARTY WITHOUT THE CONSENT OF THE COMPANY.

UNLESS OTHERWISE STATED: ALL DIMENSIONS IN MILLIMETRES. DO NOT SCALE. TOLERANCES ARE TO BE: 1 DECIMAL PLACE ±0.5, 2 DECIMAL PLACES ±0.3, 3 DECIMAL PLACES ±0.1

3rd ANGLE PROJECTION

ISS/REV	AMENDMENTS	ECO	DRN	CHKD	AUTH	APVD	DATE
A	ORIGINAL	-	KJS	RC	RC	DP	03-09-13

tyco
Fire Protection Products
 TYCO FIRE PROTECTION PRODUCTS
 17 MARY MULLER DRIVE
 P.O. BOX 19545
 CHRISTCHURCH, PH: +64 3 3895096
 NEW ZEALAND. FAX: +64 3 3895938

MX1
I-HUB / FIBRE OPTIC MODEMS
8U GEARPLATE POSITIONS

DRAWING No: **1982-71** SHEET **160** of **N**

A3	ISS/REV A	PART No:
-----------	------------------	----------

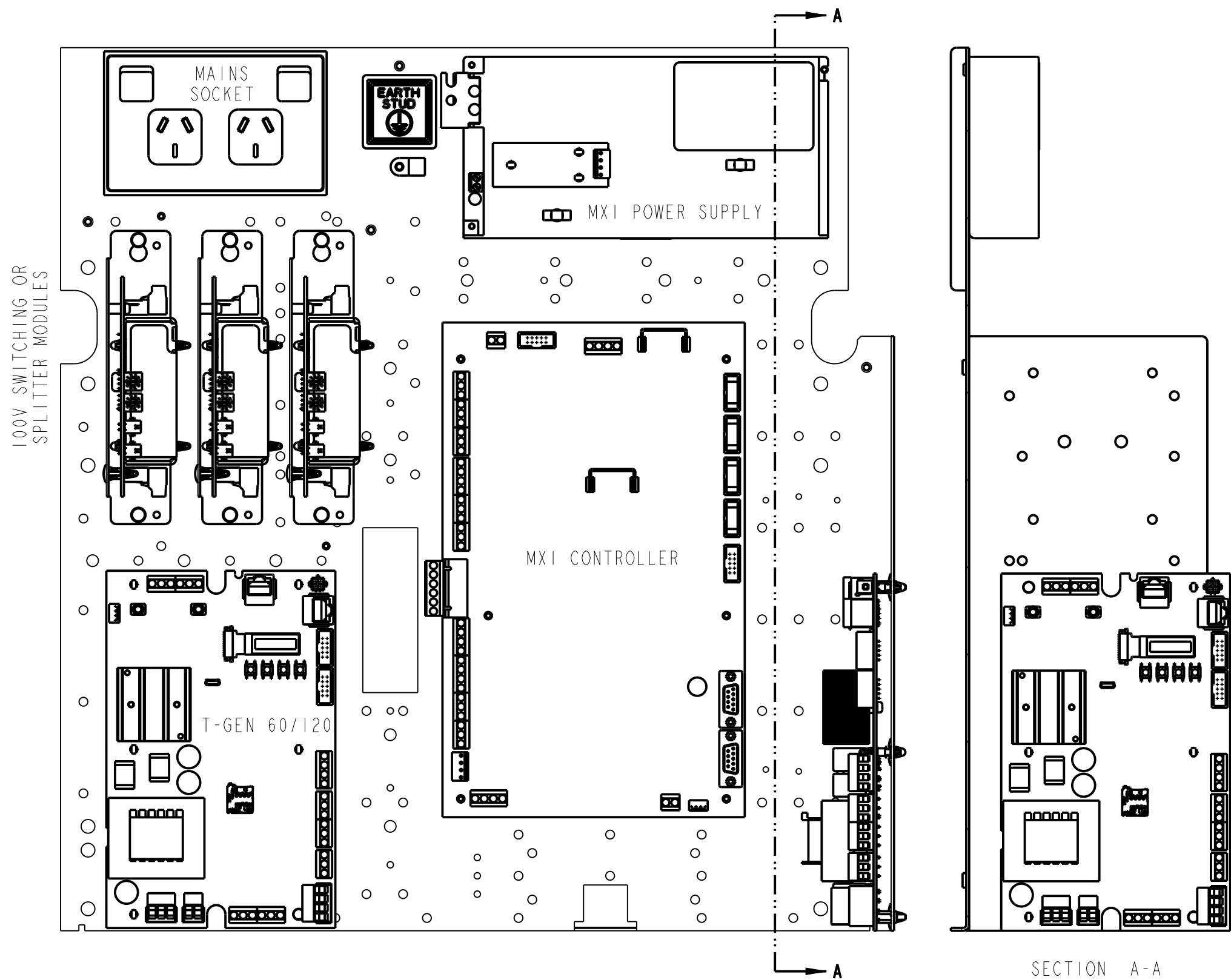

NOTES:

1. MOUNT T-GEN 60 USING 5 PLASTIC STAND-OFFS (HW0130) AND 1 OFF M3 X12 SCREW (SC0177). STAND-OFFS FACTORY FITTED FROM GEAR PLATE REAR.
2. MOUNT T-GEN 60 ON SIDE FLANGE USING 2 OFF M3 M/F BARREL NUTS (FA2552) AND 2 OFF M3 X 6 SCREWS (SC0172) FITTED TO J19 AND J26. 4 PLASTIC DOUBLE BARB PCB STAND-OFFS (HW0052) ARE FITTED TO THE 4 REMAINING HOLES. BARREL NUTS AND PLASTIC DOUBLE BARB PCB STAND-OFFS ARE FITTED FROM SIDE FLANGE FRONT.
3. MOUNT T-GEN 120 WITH 4 OFF M4 X10 SCREWS (SC0176) USING M4 LOOP CARD BRACKET MOUNTING HOLES IN GEAR PLATE.
4. MOUNT EACH 100V SWITCHING OR SPLITTER MODULE WITH 2 OFF M4 X10 SCREWS (SC0176) USING M4 LOOP CARD BRACKET MOUNTING HOLES IN GEAR PLATE.

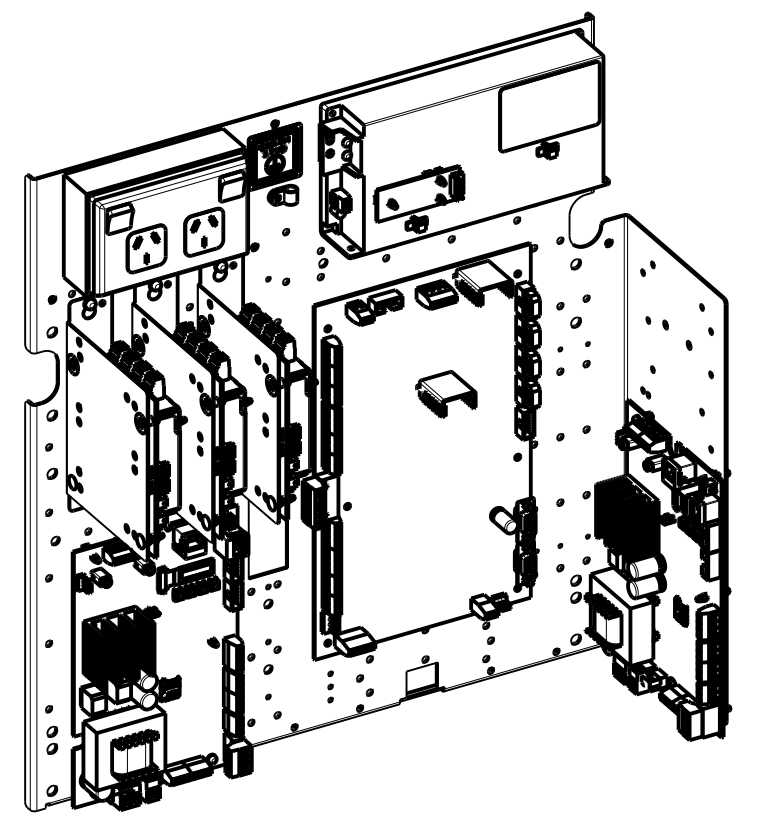

ISOMETRIC VIEW
SCALE 0.200

SECTION A-A

CONFIDENTIAL. THIS DOCUMENT MUST NOT BE COPIED NOR THE CONTENTS PASSED ON TO ANY THIRD PARTY WITHOUT THE CONSENT OF THE COMPANY.

UNLESS OTHERWISE STATED: ALL DIMENSIONS IN MILLIMETRES. DO NOT SCALE. TOLERANCES ARE TO BE: 1 DECIMAL PLACE ±0.5, 2 DECIMAL PLACES ±0.3, 3 DECIMAL PLACES ±0.1

3rd ANGLE PROJECTION

ISS/REV	AMENDMENTS	ECO	DRN	CHKD	AUTH	APVD	DATE
A	ORIGINAL	5053	KJS	RC	RC	DC	9-8-17
B	T-GEN 60 SIDE FOLD MTG ADDED.	5142	KJS	PV	RC	DC	15-10-18

© 2017 Johnson Controls. All rights reserved. All specifications and other information shown were current as of document revision date and are subject to change without notice.

JOHNSON CONTROLS
17 MARY MULLER DRIVE
P.O. BOX 19545
CHRISTCHURCH, PH: +64 3 3895096
NEW ZEALAND. FAX: +64 3 3895938

MX1
T-GEN2, 100V SWITCH/SPLITTER
GEARPLATE POSITIONS

DRAWING No: **1982-71** SHEET **169** of **N**

A3	ISS/REV B	PART No:
-----------	------------------	----------

8.3 MX Loop Card

Multiple MX Loop cards (FP0950) can be mounted inside the MX1 cabinet to provide additional loops of up to 250 MX devices each. Drawings 1982-71 sheets 140, 142, 143 and 156 show some possible mounting positions.

The cards must be connected to the appropriate Serial Port Connectors on the MX1 Controller to match the SmartConfig configuration.

Details on mounting the card and connecting it to the Controller for communication and power are detailed in the MX Loop Card Installation Guide (LT0443).

8.4 Wiring a Strobe for External Alarm

The standard MX1 Australian template is preconfigured to use a 40020 strobe wired to ANC2, supervised with the 40020 strobe profile, as the External Alarm.

The 40020 strobe is wired as per Figure 8.1. Note that there is no requirement for extra diodes or EOL resistors. The 5E6 current limiting resistor (included with MX1) must be fitted in the strobe unit.

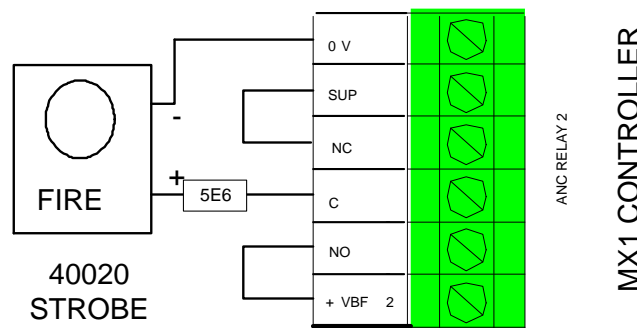

Figure 8.1 – 40020 Strobe Wiring as External Alarm

If a strobe other than the 40020 strobe is used, then it will be necessary to assess the characteristics of the strobe and its in-rush current to determine how it can be supervised. This may require the use of series diodes and/or a suitable end of line resistor. This assessment would be the same as for the addition of any other device to an ancillary output, and may require the use of an output other than ANC2 as described here.

8.5 Application – Connection to Sprinkler Systems

A sprinkler system may be connected to an MX1 for the purposes of

- Having the MX1 activate an alarm routing output when the sprinkler system is activated, for those sprinkler systems sharing an ASE with the fire alarm system.
- Having the MX1 activate its alarm devices when the sprinkler system is activated.
- Having the MX1 indicate the status of flow and pressure switches that are part of the sprinkler system.

The connections from the sprinkler system can be made using suitable input modules, as described in this section.

The inputs may need to use Delay profiles to make them operate appropriately, particularly for flow switches which may be subject to the effects of water hammer.

The effect of the inputs is determined by the configuration of the zones that are used for annunciation and control of outputs.

8.5.1 Connection using a SIO800, CIM800, or MIM800

8.5.1.1 Wiring

The SIO800, CIM800 or MIM800 must be located adjacent to the sprinkler switch. A SIO800 will be the best module to use if there is a drain valve at the same location to control with a relay output – otherwise an additional module will be required.

The alarm output from the sprinkler system can be wired directly to the MIM800 as shown in Figure 8.2. For the CIM800 refer to Figure 5.6, using the circuit configuration and profile appropriate to the sprinkler output (normally open or closed). The ELD resistor for both the MIM800 and CIM800 is 200Ω.

For wiring to the SIO800 refer to Figure 5.18 and use the circuit configuration appropriate to the sprinkler output (normally open or closed). The ELD resistor is 3.3kΩ. A 680Ω alarm resistor should be employed if short circuit fault monitoring is desired.

“NO” and “NC” refers to the state of the switch when the system is normal.

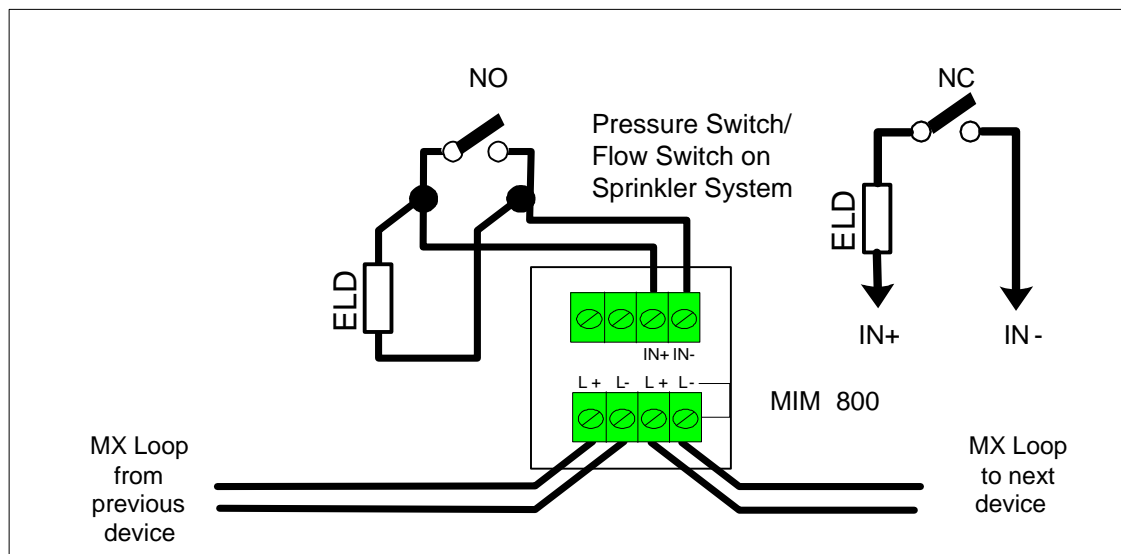

Figure 8.2 – Wiring of MIM800 to Sprinkler System

8.5.1.2 Configuration

This sample shows typical settings in SmartConfig for an input subpoint of the MX module used:

- Alarm Type – other.
- Zones – as required
- Point text – **Sprinkler, Flow switch** plus location.
- Alarm type text – **PSW** or **FSW** depending on source of activation
- Latching – unticked
- Can be disabled – Yes
- Profile – **N/O SC Alm OC Flt** for NO contact from sprinkler system, or **N/C SC FLT OC Alm** for NC contact.
- Delay Profile
 - **FS15, FS30, FS60**, or other similar input delay profile, particularly for flow switches and pressure switches that are not already retarded
 - **None**, if the sprinkler system switch is already retarded (e.g. an input from FBA/DBA Pressure Switch).

- Event Logging Profile (as required) and Point Flags Profile (generally Standard will do).

8.5.2 Connection using a General Purpose Input

8.5.2.1 Wiring

The alarm output from the sprinkler system can be wired to an *MX1* GP Input as shown in Figure 8.3. The ELD resistor can be any value between 1.5kΩ and 3.3kΩ. 2.7kΩ ELD resistors are provided with the *MX1*.

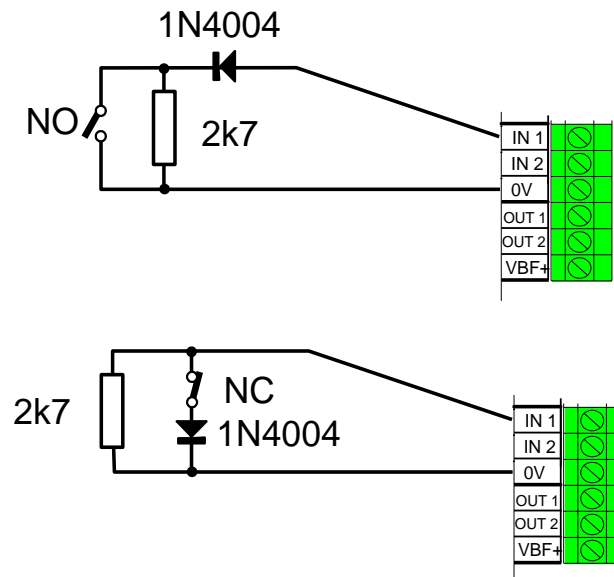

Figure 8.3 – Sprinkler System Connection to *MX1* via GP Input 1

8.5.2.2 Configuration

This sample excerpt from the “Controller Points” page of SmartConfig shows settings for the GP Input 1 point:

- Zones – as required
- Point text – **Sprinkler, Flow switch** plus location.
- Alarm Type Text – **FSW** or **PSW** as appropriate
- Can be Disabled – Yes
- Supervision Mode – **Evac Input (NO)** or **Evac Input (NC)**
- Logging Profile (as required) and Point Flags Profile (generally Standard will do)

WARNING: if the sprinkler system is connected to the GP input in this way, there are no significant retardation delays to mask the effect of water hammer, etc., so the output from the sprinkler system must include its own retard delay.

If a GP Input is used to directly monitor a switch that has no built-in retard delay, then the combination of a pseudo-point and a logic equation can be used to provide a suitable delay into alarm, as follows:

```
;delay the alarm due to GP1 activation by 15 seconds
TSnnn (15,1)FO = P241/2/0AL
;use the timer to create a pseudo point alarm
PP242/pppAL = Tnnn
```

The pseudo-point ppp must be mapped to the sprinkler zone, and have an Alarm Type Text of “FSW” for correct display on the front panel. The GP input would not map to a zone in this case.

Alternatively, it may be possible to provide a retard delay of up to 25 seconds, using a custom Controller I/O profile. Configuration of such a profile requires special consideration, and is beyond the scope of this manual.

8.5.3 Configuration of Zones for Use with Sprinklers

The annunciation of sprinkler alarms and subsequent activation of *MX1* alarm routing and alarm devices is determined by the zones that the inputs map to. This is discussed in the following sections.

8.5.4 Annunciation of Flow Switch Activations

Activation of a flow switch should trigger some indication of its occurrence. This can be achieved by mapping the input to a zone that has the “Flow Switch” zone profile.

This profile provides a simple non-latching alarm status for recall, and display on a zone LED display (if fitted). Alarm routing and Alarm Devices are not activated, and there is no alarm placed into the alarm list.

This profile is also configured to perform an ‘end to end’ flow switch alarm test, whereby an *MX1* output such as a SIO800 or RIM800 is wired to operate a drain valve. The *MX1* output is also mapped to the flow switch zone using SmartConfig. When the zone is alarm tested, the *MX1* output operates the drain valve and the subsequent water flow activates the flow switch, which then creates the alarm on the *MX1*.

If this test option is not required then the **Flow Switch No Drain Valve** profile can be used.

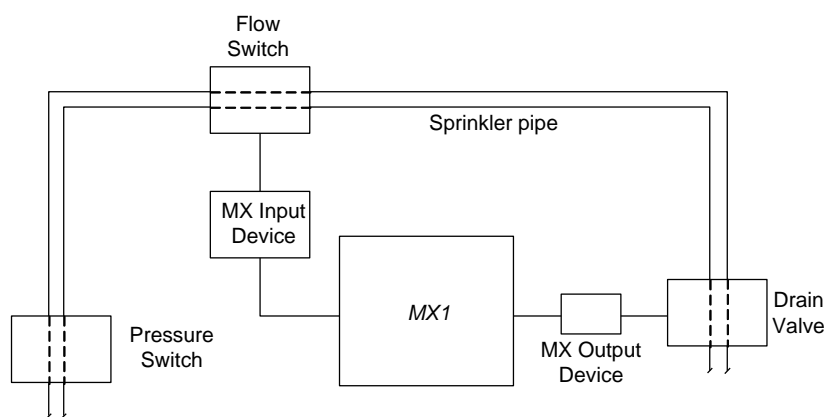

Figure 8.4 – Flow Switch Testing using *MX1*

8.5.5 Sprinkler System Annunciates as an *MX1* Alarm - Monitoring Combined

It is possible to have the *MX1* annunciate a sprinkler alarm as a general alarm, and share a single connection to the fire brigade and/or monitoring service. This is summarised in Figure 8.5.

As such, the alarm is displayed in the alarm list, the alarm routing is activated and the alarm devices are activated.

To do this, simply map the sprinkler input to a suitably named and configured zone which uses a zone profile such as **Standard G1**.

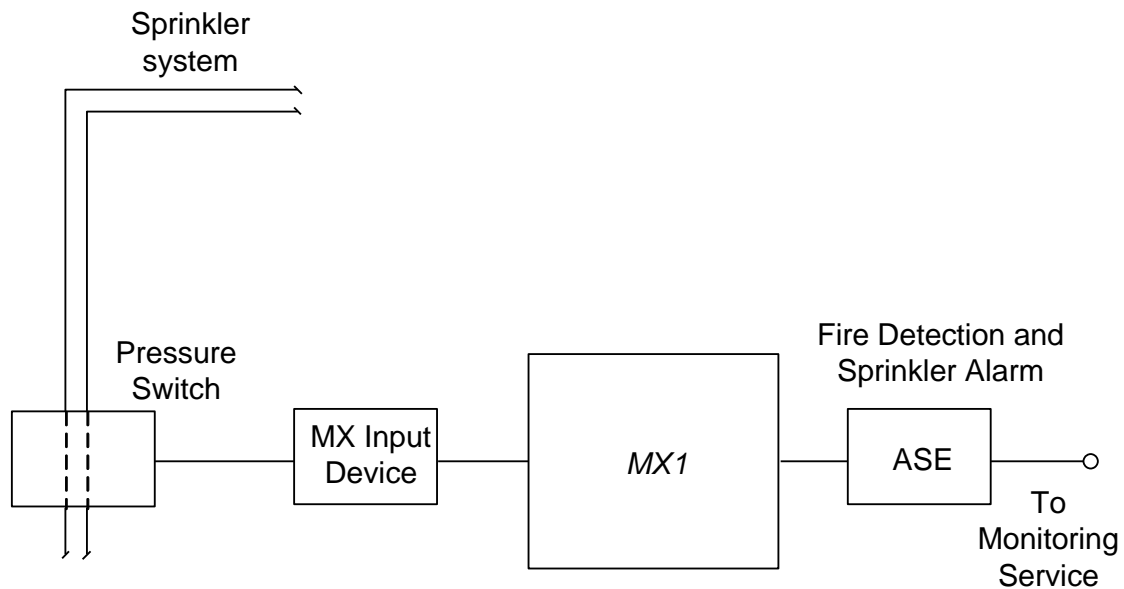

Figure 8.5 – Combined Connection to Monitoring Service

8.5.6 Sprinkler System Monitored as a Separate Alarm

It is possible to have the *MX1* announce a sprinkler alarm as a general alarm, but have separate connections for the *MX1* and the sprinkler to the fire brigade and/or monitoring service.

As such, the alarm is displayed in the alarm list and the alarm devices are activated, but the *MX1*'s standard alarm routing is NOT activated for a sprinkler alarm.

To do this, simply map the sprinkler input to a suitably named and configured zone which uses a zone type profile such as **Sprinkler FBA/DBA**.

If the sprinkler itself has its own alarm routing connection, e.g. a separate input to an ASE, then no further configuration is required.

If the *MX1* needs to activate a separate relay output to signal a sprinkler alarm, then a suitable output should be chosen, and output logic used to turn the output on when the sprinkler zone is in alarm and the alarm routing is not disabled.

```
; Activate ANC2 relay for the sprinkler zone 16 alarm  
; so long as alarm routing is not disabled.  
$ANC2_RELAY = Z16AL and not $ALARM_ROUTING_DISABLED
```

This is summarised in Figure 8.6.

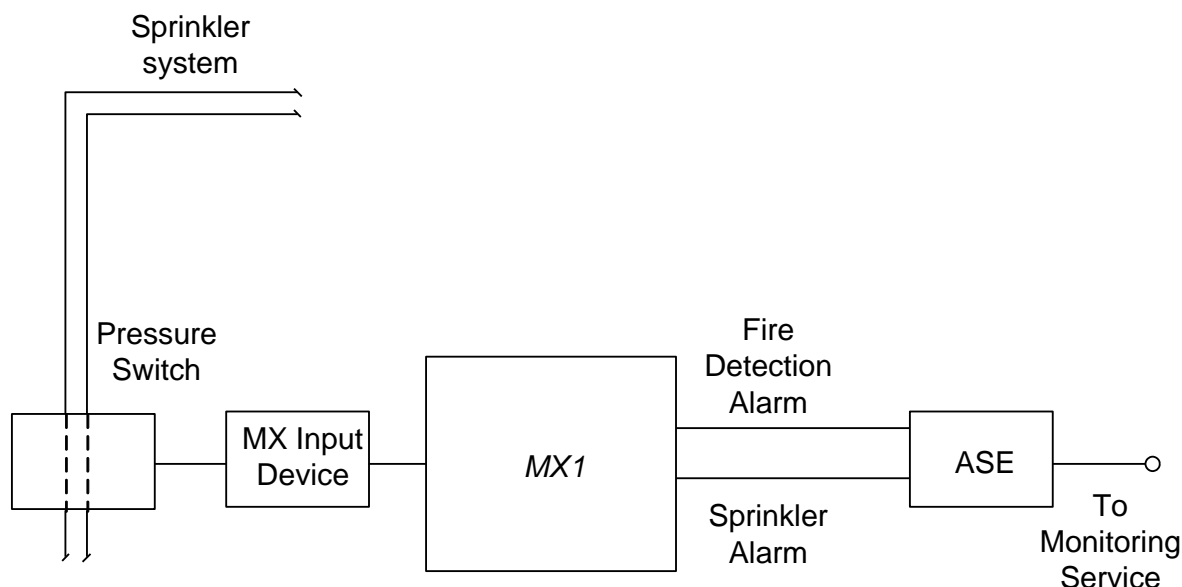

Figure 8.6 – Separate Sprinkler and Detection Monitoring Connection

8.6 Application – Fault Monitoring

Quite often the *MX1* will need to monitor the fault output of other equipment. The *MX1* GP inputs, unused Ancillary relay supervision inputs and *MX* module inputs can provide supervised inputs. Additionally, the switch inputs on the LCD/keyboard could be useful for either normally-open or normally-closed contacts, but they require more complex setups.

The other unit's fault output will generally need to be voltage free (normally open or closed), unless the 0V terminals of the *MX1* and the other unit are joined – not suitable for *MX* module inputs as these must be voltage free.

A suitable input profile must be used – examples are shown in the following table. Additionally a Point Flags Profile of **Map Fault to Brigade, No Test** should be used to generate a fault directly from the point.

Input	Input Profile	ELD
GP Inputs	Ext Fault	2k7
GP Outputs	* Ext Fault Input – GP Out	2k7-4k7
Anc 1 Sup	Ext Fault Input – Anc 1/Anc 2 Supv	4k7-10k
Anc 2 Sup	Ext Fault Input – Anc 1/Anc 2 Supv	4k7-10k
Anc 3 Sup	Ext Fault Input – Anc 3 Supv	2k7-10k
MIM800/801	Ext Fault Input	200 ohm
CIM800	Ext Fault Input	200 ohm
MIO800	Ext Fault Input	200 ohm
QIO850	Ext Fault Input	3k3 ohm
Keyboard Inputs	See Text	-
* GP Out requires a 10k pull up resistor from GP Out to +V. Refer to Section 8.19.3.		

Using keyboard inputs is slightly more complex programming-wise. For each fault condition a pseudo point must be allocated and given suitable Pt Text and a Point Flag Profile of **Map Fault to Brigade, No Test**.

A logic equation also needs to be entered to put the pseudo point into fault when the keyboard input is in fault – ActiveInput for normally open contacts, Not ActiveInput for normally closed contacts. For example:

$$PP10/0FA = \text{Not } P243/12/0AI$$

to use an open circuit on keyboard input 11 to put pseudo point 10 into fault.

Figure 8.7 shows generalised wiring diagrams for the inputs.

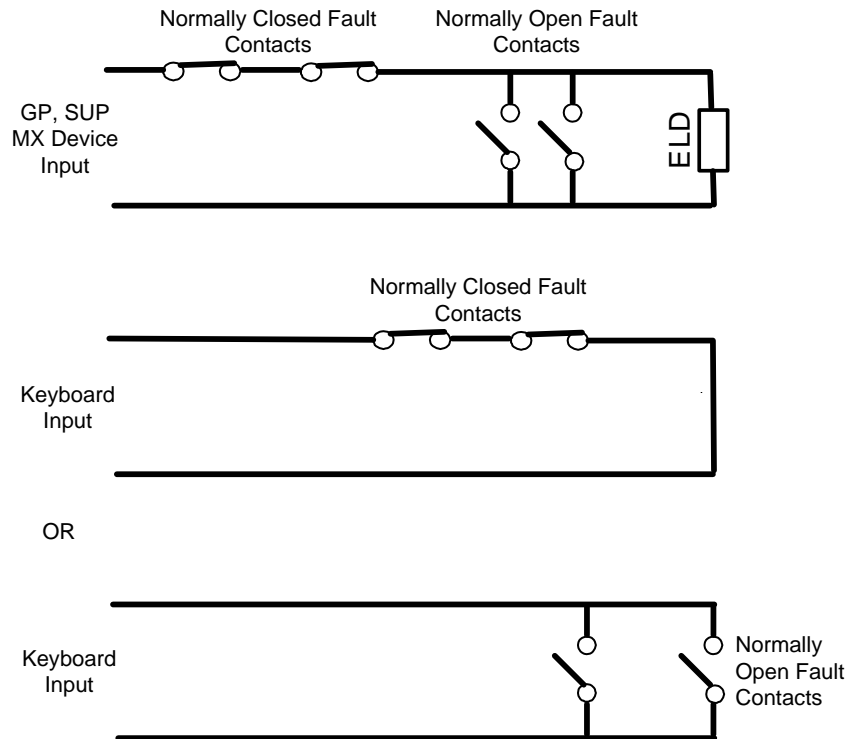

Figure 8.7 – Input Wiring for Fault Monitoring

8.7 Application - Remote Buzzer Output

The *MX1* buzzer will sound if there is a fault in the system. In situations where this buzzer would not be sufficiently loud to attract attention, an external fault sounder can be connected and sited where staff are able to hear it. It should be clearly labelled “FIRE ALARM FAULT BUZZER, ADVISE FIRE ALARM SERVICE COMPANY” or equivalent approved legend.

A suitable 24V buzzer type is Murata PKB6-540 (SN0001) or OBO 54-35C1 (SN0017).

See Section 8.8 for configuration of a fault buzzer cancel switch input.

8.7.1 Wiring

The external fault buzzer can be controlled from any output on the *MX1*, e.g. ANC1 to ANC3, GP Out 1 or 2, or an *MX* module such as LPS800, SNM800, or a Quad I/O module.

Warning: Use of other *MX* loop solutions that use power from the loop are not suitable and may compromise operation of the system.

Fig 8.8 shows an example with the buzzer wired to the Iso/Disable alarm routing relay, which is available if there is no brigade signalling required.

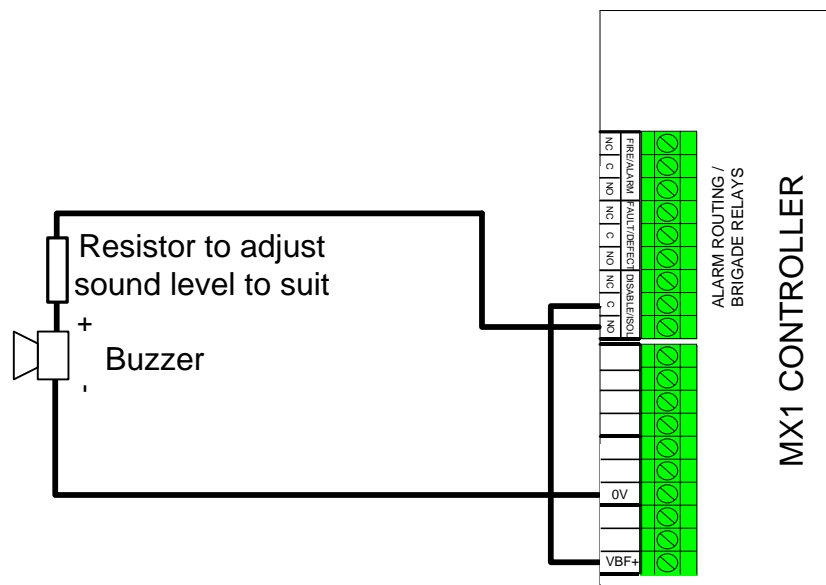

Figure 8.8 – External Fault Sounder Wiring Details

8.7.2 Configuration

The standard template includes two logic substitutions that can be used to activate external fault outputs.

\$KEYPAD_FAULT_SOUNDER_ON operates continuously
\$KEYPAD_FAULT_SOUNDER_DRIVE is on for 1 second every 30 seconds.

To activate the disable signalling relay the following logic could be used (edit the existing equations):

```
$FREE_USE_BRIGADE_RELAYS = TRUE
$FREE_USE_DISABLE_RELAY = $KEYPAD_FAULT_SOUNDER_ON
```

8.8 Application - Fault Buzzer Cancel Input

In installations that must provide fault sounder silencing at Access Level 1, or those using a remote fault buzzer (see the previous section), it may be necessary to have provision for staff to acknowledge it and cancel the sounder operation. In general, local standards require that this buzzer cancel facility be self-resetting, i.e., if the fault clears and then recurs, the buzzer will start sounding again.

8.8.1 Wiring

A push button to cancel the fault buzzer should be mounted in a location accessible by staff authorised to use it, but away from access by unauthorised staff. This control is a simple normally-open momentary contact, and for this example it is wired to one of the GP Inputs on the MX1 Controller. The following assumes that GP Input 1 has been used, but applies equally to using GP Input 2 or other input devices such as a MIM800.

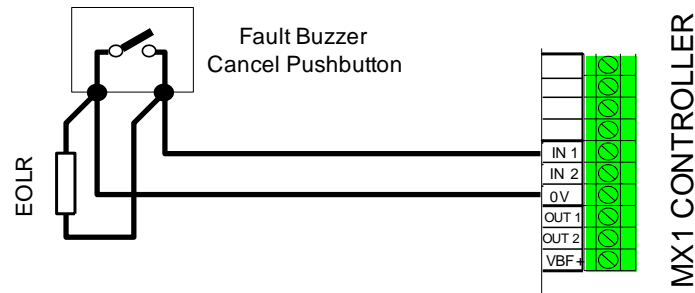

Figure 8.9 – Fault Buzzer Cancel Pushbutton Connection via GP Input 1

The ELD to normalise the input should be selected to be an appropriate value. The input's operational profile used must be configured for short circuit = active input, open circuit = fault, otherwise Normal.

8.8.2 Operation

When the fault sounder on the *MX1* is on, staff will operate the control. The control's active input state makes \$EXT_FAULT_SOUNDER_CANCEL go TRUE. In response the *MX1* system turns off the fault sounder, and appropriately configured external fault sounders.

8.8.3 Configuration

The input's **Active Input** state is entered into the \$EXT_FAULT_SOUNDER_CANCEL equation, e.g.,

$$\text{\$EXT_FAULT_SOUNDER_CANCEL} = \text{P241.2.OAI}$$

8.9 Application – Door Holder Control

Door holders for smoke stop doors are normally powered from the non-battery-backed supply. During non-alarm conditions, the door holders are energised, being released on alarm or mains fail conditions.

8.9.1 Wiring

The wiring to achieve this using the Ancillary Relay 2 on the Controller, with supervision for open circuit of both positive and negative wiring, is shown in Figure 8.10. Ancillary Relay 1 could equally well be used.

Ancillary Relay 3 could also be used, but does not have an appropriate supervision mode.

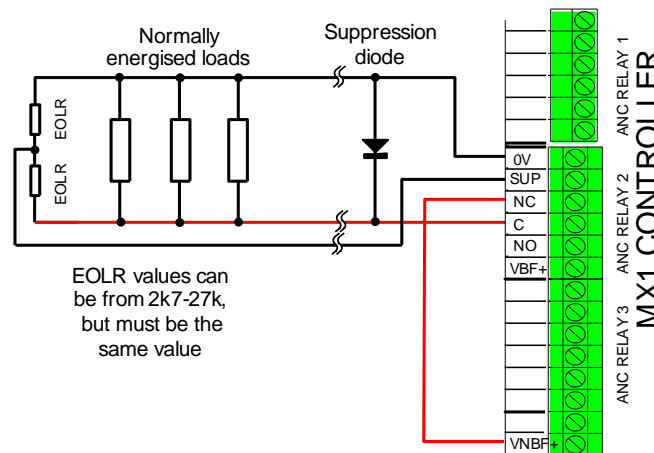

Figure 8.10 – Door Holder Wiring to Ancillary Relay 2 with Supervision

The ELD resistors for the door holder chain can use the ELDs supplied with the *MX1* that are not otherwise used.

8.9.2 Configuration

In the “Controller Points” window, for the “Anc2 Supervision” point (ANC2S), select supervision mode as **Door Holder**.

Also set the “O/P Control” setting to **Logic** and enter an equation such as:

$$CZBRALM + NOT \$MAIN_POWER_OK$$

8.10 Application – Event Logging Printer

During its operation, *MX1* generates events when the states of zones and points etc. changes. Events are held in non-volatile storage and can be viewed on the front panel display, but only the most recent 900 events are retained, with older messages being lost. An event printer can be connected to *MX1* to create a hard copy of every event.

The MX4428 thermal printer, part number FP0546, is suitable, and can be powered from the system 24V supply with Printer option Kit FP0545. Note that a serial crossover cable (LM0076) will also be required for use with *MX1*. Note also, that this printer has a standby current draw of 100mA which must be included separately in the battery calculations.

Other serial-input mains-powered printers may also be used – refer to ‘Wiring’ and ‘Configuration’ below.

Events which are printed include:

- Zone and Point Events, e.g. Alarm, Fault;
- Zone and Point Commands, e.g. Reset, Disable;
- System events, e.g. communication failures, battery faults, etc.

Events for each zone and point can be individually configured to be logged to the internal event history or to the event printer, or to both. This is controlled via the Logging Profile assigned to the zone or point.

The event printout includes the time and date, the cause of the event, and the event type. Events and commands for zones and points that have a text name programmed also have

the name printed. *MX1* is able to store at least 900 events for printing, being the first 900 events to occur.

As events are printed, more events are able to be put into the list. If events cannot be put into the list because it is full, *MX1* keeps a count of those events it has had to discard. When *MX1* is able to put more events into the list, it prints out the number of events it had to discard.

MX1 has a dedicated printer output – Serial Port 1. However, with V1.51 firmware onwards, it is possible to configure *MX1* to output the printer events using the Diag/Prog port. Refer Section 12.1.9.

8.10.1 Wiring

The printer's serial input port is connected to the Serial Port 1 connector (J23) on the *MX1* Controller. The connecting cable must be a "crossover" or "null modem" type with female DB9 connectors at both ends. Vigilant part number LM0076 is a suitable cable for this.

Many printers have serial ports with the Signal Ground connected to the incoming mains earth lead. Connecting such a printer to *MX1* will cause an Earth Fault, since it will also earth the 0V of the *MX1*. This can be dealt with in one of several ways:

- Ignore it – if Earth Fault monitoring can be ignored without sacrificing the reliability and serviceability of the *MX1* system, then the Earth Fault point can be configured in SmartConfig to be hidden and not logged. Most templates will have suitable Points Flags and Logging profiles for this.
- Use an isolating transformer to power the printer. A rating of 250VA is typically the smallest size of isolating transformer available, and this should be sufficient for almost any small dot matrix or inkjet printer.
- Use a serial isolating device on the serial connection between the printer and the *MX1*. There are a number of commercial units which could be used for this purpose. Note that this option will be no less expensive than the isolating transformer option, and may not be any more compact. Isolating transformers are generally much more readily available than these serial isolation devices.

8.10.2 Configuration

MX1

In the "System" window of SmartConfig,

- Select a baud rate to match the printer. In general, there is no advantage in a higher rate than the printer can keep up with, so in most cases, a baud rate of 1200 bps will be adequate.
- Select the number of lines per page. For A4 sized paper, the default of 60 lines is usually acceptable.
- Check or uncheck the selection boxes for the other printer options, as required.

Event messages are always sent to Serial Port 1 whether there is any printer connected to it or not.

Logging network events

The logging profile assigned to each zone or point selects whether events are sent on the network for that zone / point. The selection of whether system events are sent on the network is made on the "System" page in the "Printer" group where there is a checkbox "Log system events to network". When *MX1* receives an event from another panel it firstly checks whether it should log events for that SID – this is configured in the SID config profile for each SID. *MX1* then checks whether events of that type should be printed or not. These settings

are on the “System” page in the “Printer” group - “Print zone events”, “Print point events” etc. For “Print point events”, this enables the logging of both compatible point events, as well as sub-point events. For events received from MX1 panels, only the latter are logged.

Printer

Referring to the printer’s documentation,

- Select a baud rate to match the setting in *MX1*. If there are several ports on the printer, select the one that is connected to the *MX1*.
- Select the data format to be 8 bit characters, with no parity checking.
- Set the printer to a page length matching the paper being used, e.g., 11 inches for Letter size, 11.7 inches/297mm for A4 size.

8.11 Application – Avoiding Relay “Chatter”

Logic equations are used directly or indirectly to control most of the relay outputs in an *MX1* system. The complete set of logic equations is processed by the *MX1* Controller several times per second. Therefore, it is possible that an equation controlling a relay using an input that was unstable or unfiltered could result in the relay chattering, i.e., operating and releasing several times a second, in time with the logic equation processing.

This is not harmful to the relays themselves, but if these relays are controlling large loads or heavy machinery such as lifts or air handling equipment, this rapid switching could result in overheating, overload, or other damage to this equipment.

When using relays for such purposes, it is good practice for the controlling logic equations to include timers to prevent rapid on-off switching of relays in response to rapidly changing inputs.

8.11.1 Wiring

There are no specific wiring requirements with this application.

8.11.2 Configuration

These equations use a variable and a pulse timer to limit the speed at which the output can change.

```
Vnnn = ((controlling_expression) AND NOT T111) OR (Veee AND T111)
TS111(0,2)PU = VnnnE
Output_relay_point = Vnnn
```

If the controlling expression is simple, it can be incorporated directly in the first equation. If it is more complicated, it is preferable to use another variable to store the value and use this variable as the controlling expression in the first equation above.

The pulse timer is set every time the variable changes state, and the variable is held in its current state until the timer resets (in this example, after 2 seconds). Once the timer has reset, the variable follows the controlling equation again. This means that the variable will not change any more rapidly than one period of the pulse timer.

This “anti-chatter” method will respond immediately to an input change to operate the relay after a long period of being released. This can lead to false activations if the controlling expression includes input states that are not debounced or filtered. Any such inputs can be groomed by using a follow timer in this way:

TSfff(2,3)FO = noisy_input_point ; 2 second ON filter, 3 second OFF filter

In this example, the timer output will not follow the state of the input point until this has been continuously TRUE for at least 2 seconds, or continuously FALSE for at least 3 seconds.

8.12 Application – Control and Isolation of Ancillary Outputs

8.12.1 Options for Control of Building Services

When the *MX1* is being tested or serviced, it is usually necessary to prevent the triggering of fire alarm operation for critical building services such as air conditioning, plant and lifts.

A simple method to prevent outputs operating when the panel is being tested or supervised is to use the door status. This is described in Section 8.12.2.

MX1 also provides Ancillary Groups for this function, and the status of these groups is easily integrated with the output logic driving the building services to allow technicians to test or service the *MX1* system without affecting those services. Refer sections 8.12.3 and 8.12.4.

8.12.2 Using Door Status to Enabled Outputs

If it is desired to enable operation of ancillary outputs when the *MX1* door is closed (and locked) and disable them when the door is opened then the \$DOOR_CLOSED logic substitution can be used.

The \$DOOR_CLOSED substitution is true when the *MX1* lock is turned to the fully clockwise (door and keypad locked) position, thus the building services output can be operated when the door is closed.

For example, by setting the ANC 1 output point's OP Control to **Logic** and entering the logic cell to be

CZBRALM AND \$DOOR_CLOSED

ANC1 would turn on for an alarm, unless the door was open.

The door will need to be closed or the door microswitch temporarily operated, to test that the outputs *do* operate when required.

8.12.3 Using Ancillary Groups

MX1 has 4 Ancillary Groups, easily accessible through the *MX1* user interface to Enable outputs. Using these, a system designer can program the *MX1* to have up to 4 separately controllable groups of building services.

Each group is able to be individually enabled and disabled. This maps to a status point, whose disable status can be used in output logic to control the building services. *MX1* templates provide logic substitutions which simplify the integration of the disabled status into output logic.

Note: The standard *MX1* Australia template predefines the fourth group to be used for disabling the printer output, but its use is not mandatory and its function can be re-assigned.

The 4 Ancillary Groups control points P241/31/0 through P241/31/3, are named “Ancil Group 0” through “Ancil Group 3”, respectively. Each point should have suitable point text programmed to describe what the Ancillary Group will be used for. Each point has an associated logic substitution, \$ANCDIS0 through \$ANCDIS3. These substitutions are used in output logic to control the ancillary functions.

Examples of how to use Ancillary Groups are in Section 8.12.4.

8.12.4 Ancillary Groups Example

A simple method is to use the point disable status to stop outputs being operated.

```
$ANC1_RELAY = CZBRALM AND NOT $ANCDIS0 ; lifts shutdown
$ANC2_RELAY = CZBRALM AND NOT $ANCDIS1 ; air conditioning shutdown
```

Both relays turn on for a brigade alarm, unless the corresponding Ancillary Group is disabled. These equations could allow a technician to confirm operation of the lifts (Ancillary Group 0 enabled) while preventing the air conditioning from shutting down (Ancillary Group 1 disabled).

For a more complicated example, consider the use of Ancillary Group3 for disabling output from the printer, which is pre-programmed into the standard Australian template. This shows how an Ancillary Group can be programmed with text and be integrated into output logic, including using output logic to update the Ancillary Group disable state.

The Printer Output point, P241/27/14, is programmed with a Point Text of **Printer Output** and has a logging profile of **Log All**, and a Point Flags profile of **Off normal Recall, no test**.

The Ancillary Group 3 Disable point, P241/31/3, is programmed with a Point Text of **Printer Output** and has a logging profile of **Log Nothing**, and a Point Flags profile of **No off normal, no test**.

Output from the *MX1* printer port is enabled when Point P241/27/14 Printer Output is not disabled. Instead of having to remember the correct point number to enable and disable, the following logic links Ancillary Disable 3 to the Printer Output point, such that the disable states of the two points are kept synchronised. Thus, a user can more easily stop printer output by disabling Ancillary Disable 3. This logic makes use of logic substitutions and concatenation of tokens (using #), and also shows how output logic can be used to update the Ancillary Disable status.

```
; =====
; Printer Output Control
; Ancillary Disable 3 is used to control the printer output.
; Get current disable states for Printer Control and Ancillary Disable 3. Then see if have to change the
; other to match.

; get the disable status of the printer control status point
$PNT_PRINT_CONTROL_DIS = $PRINT_CONTROL_DIS
; disable Ancillary Group 3 if it is not disabled and the printer is disabled.
$ANCDIS3 = $PNT_PRINT_CONTROL_DIS#P and not $ANC_PRINT_CONTROL_DIS
; enable Ancillary Group 3 if it is disabled and the printer is not disabled
$ANCDIS3ENA = $PNT_PRINT_CONTROL_DIS#N and $ANC_PRINT_CONTROL_DIS
; get the disable status of Ancillary Group 3
$ANC_PRINT_CONTROL_DIS = $ANCDIS3
; disable the printer if it is not disabled and Ancillary Group 3 is disabled
$PRINT_CONTROL_DIS = $ANC_PRINT_CONTROL_DIS#P and not $PNT_PRINT_CONTROL_DIS
; enable the printer if it is disabled and Ancillary Group 3 is not disabled
$PRINT_CONTROL_ENABLE = $ANC_PRINT_CONTROL_DIS#N and $PNT_PRINT_CONTROL_DIS
```

8.13 Alarm Routing Fault Input

Some Alarm Routing Equipment may be able to signal to the *MX1* that a fault condition exists. This fault could be caused by the alarm routing equipment itself, or a problem with the communication path.

MX1 is able to use any available input compatible with the fault signal to monitor for these Alarm Routing faults. Once the input has been selected and configured, all that remains to be done is add a logic equation for ARF based on that input. For example,

$$\text{ARF} = \text{P241.2.OAI}$$

if the GP Input 1 active input condition is used to signal an alarm routing fault.

8.14 Application - Generating Alarms and Faults using Output Logic and Pseudo Points

There are some circumstances where it is desirable to generate an alarm condition from some combination of statuses that are not direct alarms from detectors, sensors or other field inputs. For example, generating a brigade calling alarm if a non-brigade calling alarm exists for more than, say 15 minutes, or generating an alarm for some combination of inputs not supported by zone processing.

One method to produce such an alarm is to have output logic operate an output that is wired back into an alarm generating input. However, this uses up system inputs and outputs unnecessarily.

MX1 allows for alarms, and faults, to be created from output logic equations by using pseudopoints, which removes the need for external I/O and wiring.

From the *MX1* perspective, pseudopoints are handled as real points able to be mapped to zones, can be disabled, have point flags profiles assigned, and so forth like other points in the system. They differ from other points in having no physical existence from which to generate alarm and fault conditions. Instead, a pseudopoint's alarm and fault status is determined by output logic equations. When the logic equation that determines a pseudopoint's alarm status goes TRUE, the pseudo point enters the alarm state, which is then processed as any other point alarm - events can be logged, mapped zones go into alarm, etc. When the logic equation that determines a pseudopoint's alarm status goes FALSE, the pseudo point exits the alarm state, any mapped zones can be reset, and so forth.

8.14.1 Examples

Example 1:

To call the brigade if a non-brigade calling zone, Zone 5, is in alarm for more than 20 minutes, using pseudopoint 1 mapping to Zone 1, which is a brigade calling zone.

a) Configure pseudo point 1, P242.1.0. Map the point to Zone 1, enter appropriate point text. Set its logging profile as desired. Set its Point Flags profile to **Standard**.

b) Configure the logic equation:

TM1(20,0) FO = Z5AL ; Timer 1 goes true after zone 5 is in alarm for 20 minutes.
PP1/0AL = T1 ; PP 1 goes into alarm when the timer runs out.

When zone 5 goes into alarm, the timer starts. After 20 minutes the timer output goes TRUE, which makes pseudo point 1 go into the alarm state. The normal point to zone mapping process puts Zone 1 into alarm and calls the brigade.

Example 2:

To signal a fault if a user disables a specific zone, for example, Zone 12.

a) Configure pseudo point 2, P242.2.0. Enter appropriate point text. Set its logging profile as **Log All**. Set its Point Flags profile to **Map Fault to brigade, no test**.

b) Configure the logic equation:

PP2/0FA = Z12DIS ; PP 2 goes into fault if zone 12 is disabled.

If Zone 12 is disabled, pseudo point 2 goes into fault and directly signals to the monitoring centre by activating the fault relay.

8.15 VIO800 Application for LaserPLUS or LaserSCANNER

For the VIO800 application the MIO800 is supplied on a mounting bracket ready for installation behind the left-hand cover of the LaserPLUS or LaserSCANNER.

The recommended wiring between the MIO800 and the LaserPLUS or LaserSCANNER is shown in Figure 8.11. With this arrangement the states transmitted by the MIO800 inputs and outputs are:

- Input #1 = Fire1 and Urgent Fault
- Input #2 = Action and Minor Fault
- Input #3 = Alert and PSU Fault
- Output#1 = Reset (optional)

These should be programmed in the *MX1* as required. A suitable MIO800 profile called VIO800 is available in SmartConfig to set the input thresholds. The inputs should be mapped to appropriate zones as required, and output logic written for the reset output if required.

Wiring Details

The relays on the VESDA may be used in their default configuration subject to the following caution.



In the default configuration, isolating the VESDA unit will stop the VESDA creating any alarms or faults, but this is not indicated on the relay outputs wired to the MIO800. It is recommended that the VESDA unit be programmed so that Relay 3 drops out for Urgent Fault or Isolate. This way isolating the VESDA unit creates a fault on the *MX1*.

In their default configuration, the alarm relays on the VESDA are normally non-energised and latching and the fault relays are normally energised and latching. The following table provides full details.

Relay #	Default Signal	Default State	Latching	VIO800 – Standard Configuration
1	Isolate	non-energised	Not applicable.	NOT REPORTED *
2	Minor Fault	energised	Yes	Reported as S/C on I/P #2
3	Urgent Fault	energised	Yes	Reported as S/C on I/P #1
4	Alert	non-energised	Yes	Reported as alarm on I/P #3
5	Action	non-energised	Yes	Reported as alarm on I/P #2
6	Fire 1	non-energised	Yes	Reported as alarm on I/P #1
7	Fire 2	non-energised	Yes	NOT REPORTED

* See caution above

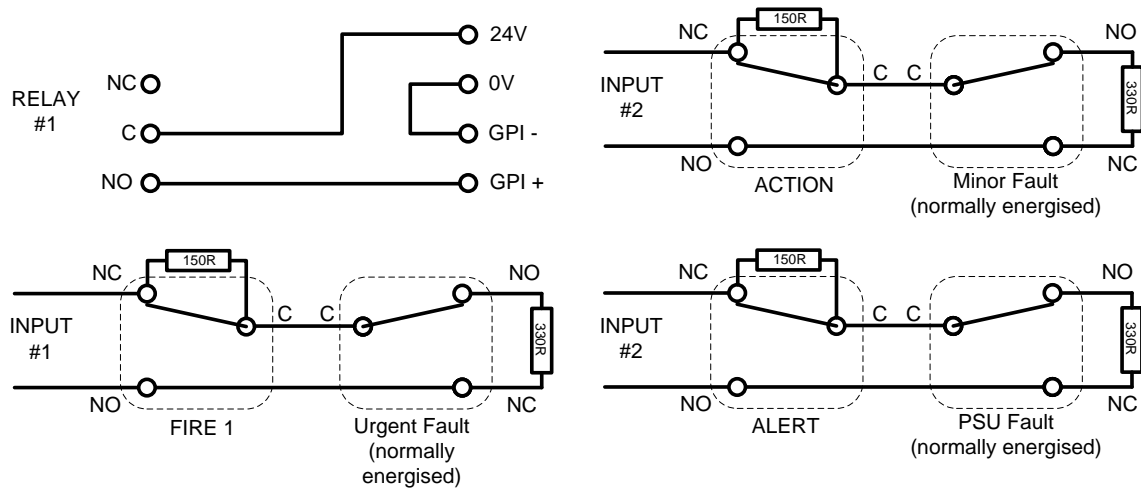

Figure 8.11 – Wiring of MIO800 to LaserPLUS and LaserSCANNER

8.16 AIF Configuration

8.16.1 Alarm Investigation - Description and Requirements

The *MX1* Alarm Investigation Facility (AIF) allows a suitably trained operator to temporarily delay transmission of specific alarm signals to the monitoring service and activation of the alarm devices. The delay allows time to investigate the source of the alarm, so as to determine if it is a real alarm or a nuisance alarm. If the alarm is a nuisance alarm, the alarm condition can be reset.

If a second alarm occurs, or if the investigation takes too long, the *MX1* automatically activates the alarm devices and signals alarm to the monitoring service.

AIF has limited acceptance by fire authorities, requires trained operators to respond to the alarm conditions, and is not suitable for all applications.

Designers of *MX1* systems that will use AIF must be familiar with the requirements of AS 4428.10. This standard describes the requirements and limitations for AIF, and the responsibilities of building management.

NOTE : AIF should not be used on networked systems because *MX1* AIF processing has no awareness of alarms on other fire panels.

8.16.2 **MX1 AIF Implementation**

Enabling AIF operation for an *MX1* fire alarm system requires that one or more zones be configured for AIF (called AIF zones).

The presence of zones configured for AIF automatically enables AIF operation for the system, and makes the AIF key/indicator operational for use as the “Attended” control and indicator.

When the *MX1* is attended:

- AIF delays will be used for alarms from AIF programmed devices mapped to zones configured for AIF.
- Other alarms, for example a second alarm, MCP alarms or alarms from non-AIF zones, will activate the alarm devices and signal to the monitoring service without delay.
- Any programmed AVF will be bypassed for devices generating AIF alarms that map to AIF zones.

When the system is not attended:

- All alarms will activate the alarm devices and signal to the monitoring service without delay.
- Any programmed AVF operation will be used.

8.16.3 **Acknowledge and Investigate Times in AIF Zone Profile**

Operation of AIF uses an Acknowledgement delay and an Investigate delay.

The Acknowledgement and Investigate delay times must be agreed with the fire brigade and territorial authorities.

These delays are programmed into the AIF Zone profile for use by the AIF zones. It is possible to implement multiple profiles with different times, if required. Each zone uses the times programmed into its profile.

The SmartConfig template has default AIF zone profiles, with pre-set acknowledgement and investigate times. However, as an AIF system’s AIF operation must be agreed on a per site basis at time of commissioning, it is recommended that a new zone profile be created with the agreed acknowledgment and investigation times.

AS 4428.10 specifies the maximum limits for each of these settings, and SmartConfig enforces these limits. Attempts to use time delays greater than that specified in AS 4428.10 will generate an error.

8.16.4 **Zone Configuration**

Zones for which AIF operation is required must use a Zone Type Profile that enables AIF and has appropriate Acknowledge and Investigate times.

Zones that do not require AIF must not use a Zone profile with a Delay Type of **AIF**.

8.16.5 **Detection Configuration**

By default most smoke detectors mapped to an AIF zone will generate an AIF alarm when the *MX1* is attended. If specific detectors mapped to an AIF zone are not to generate AIF alarms (instead generate standard alarms) then set the Point Type as **Non AIF**.

Smoke detectors designed for use in hazardous areas will default to not generate an AIF alarm. It is recommended to not change this as fire detection in hazardous areas should not be subject to AIF delays.

The DDM800 and DIM800 are preconfigured to not generate an AIF alarm, as it is not possible for SmartConfig to reliably determine the types of detection devices being used on the conventional detection circuits. If a DDM800 or DIM800 will have suitable detectors wired to it, it can be programmed to generate AIF alarms by selecting the input Point Type as **Input 1 AIF** or **Input 2 AIF**. The DDM800 or DIM800 will usually be configured for AVF processing when smoke detectors are utilised, and this processing will be bypassed while the system is attended if the DDM800 or DIM800 is programmed for AIF alarms and is mapped to an AIF zone.

MCPs, heat detectors and module inputs are by default not able to generate AIF alarms. In the unlikely event that an alarm from one of these devices must be made subject to AIF delays, this can be changed within SmartConfig, by selecting the input Point Type as **Input AIF**.

8.16.6 Training Requirements

It is a requirement of AS 4428.10 that operators of AIF enabled systems are trained in the operation and understanding of AIF. It may be necessary for the system designer to provide assistance in the training of operators designated to handle alarms.

8.16.7 Output Logic Equations

The SmartConfig template includes 4 default equations used with AIF that can be changed for particular installations that require an external control/indication facility for AIF.

Alarm Investigation Facility - external indication and control

```
;  
; Enter inputs used for each AIF function. Set to FALSE if not used.  
$AIF_ACK_BUTTON = false ; replace false with input condition for AIF ACK button  
$AIF_RESET_BUTTON = false ; replace false with input condition for AIF Reset button  
$AIF_ATTENDED_INPUT = FALSE ; replace false with input condition for AIF Attended  
switch  
; uncomment and assign output for external AIF Attended indication  
;<AIF_ATTENDED_LED> = $AIF_ATTENDED_MODE
```

\$AIF_ACK_BUTTON should be set equal to an external input condition that is true when the AIF Ack button is pressed, e.g., P2/140/1AI for a non-alarming input on a MIM Module.

\$AIF_RESET_BUTTON should be set equal to an external input condition that is true when the AIF Reset button is pressed, e.g., P2/141/1AI for a non-alarming input on a MIM.

\$AIF_ATTENDED_INPUT should be set equal to an external input condition that is true when the AIF is attended, e.g., P2/142/1AI for non-alarming input on a MIM.

\$AIF_ATTENDED_MODE can be used to control an output (e.g., LED O/P on a MIM) to indicate when AIF is attached.

AIF_ACK_TIMER is a token that is true when an AIF zone alarm has been detected and the acknowledgement timer is running. It goes false when the alarm is acknowledged or turns into a real alarm.

AIF_INV_TIMER is a token that is true while an AIF alarm is being investigated. It goes false when the AIF alarm is reset or the timer times out and goes into full alarm.

8.17 AAF Configuration

8.17.1 Alarm Acknowledgment - Description and Requirements

The *MX1* Alarm Acknowledgement Facility (AAF) is a nuisance alarm reduction tool that allows trained occupants in Single Occupier Units (SOUs) to delay alarms being transmitted to building occupants and the fire brigade while they attempt to clear the source of the alarm.

When a smoke alarm is detected in the SOU, local sounders operate, notifying the occupants of the alarm. In response, an occupier can acknowledge the local alarm condition using the AAF Acknowledgement control. This silences the local sounder and starts a longer investigation period, which further delays the *MX1* alarm to permit the occupant to try and clear the source of the alarm. If the local alarm condition is not acknowledged, the *MX1* enters the alarm condition, notifies the monitoring service and activates the alarm devices.

If the occupier, having acknowledged the local alarm, determines the alarm to be a nuisance alarm, such as burnt toast, they can attempt to remove the source of the alarm, e.g. by opening a window or clearing smoky air from the detector. If the detector alarm condition clears within the investigation period, then the *MX1* does not enter the alarm condition. If the detector remains in alarm throughout the investigation period, the *MX1* enters the alarm condition, notifies the monitoring service and activates the alarm devices.

An alternative arrangement that has no alarm acknowledgement module, activates the local sounders on a smoke alarm; with the occupants having to clear the smoke (alarm) by the end of a delay, otherwise the *MX1* enters the alarm condition, notifies that monitoring service, and activates the alarm devices. See Section 8.17.7.

If a heat alarm is detected in the SOU, the *MX1* immediately enters the alarm condition, notifies the monitoring service and activates the alarm devices.



Designers of *MX1* fire alarm systems that will use AAF must be familiar with the requirements of AS 7240.2-2004 Annex ZB and AS 1670.1:2018 Clause 3.2.2, which both place requirements and limitations on using AAF. Consideration should also be given to use of sounders within the SOU that as well as performing the local annunciation function will form part of the building occupant warning system.

Each *MX1* zone may be programmed for AAF operation, and it performs its AAF function independently of the other zones. The limitation on the number of AAF zones possible will be the availability of *MX* device points for detection, local warning and operation of the Alarm Acknowledgment Module within each SOU.

8.17.2 Configuration of *MX1* AAF

Design and configuration of an *MX1* fire alarm system to use AAF follows the methods used for a standard fire alarm system, with the following extra design and configuration requirements.

MX1 V1.51 firmware and onwards:

The LED on a smoke detector mapped to an AAF zone latches on when the zone goes into alarm, because the *MX1* allows a latching detector to be non-latching during the AAF time delays, and latches the alarm state (and LED) once the AAF zone has gone into alarm.

A heat detector can be mapped to the AAF zone. AAF time delays do not apply to the heat detector unless it is configured with “AIF enabled”.

The configuration settings are as follows:

1. The smoke sensor (sub-point) mapped to an AAF zone must be configured as latching. This is so that the detector LED will latch on after the zone goes into alarm.
2. The point type for the smoke sensor (sub-point) should be set to “Smoke” (default). If the detector point type is set to “Smoke Non AIF”, the *MX1* will bypass the AAF time delays for that sensor and the zone will go into alarm immediately.

MX1 firmware prior to V1.51:

A smoke sensor (sub-point) on an AAF zone must be configured as non-latching and the point type should be set to “Smoke”. For this firmware, the smoke detector LED does not latch on when the zone goes into alarm, instead, the detector LED turns off when the detector goes out of alarm. Do not program the detector as latching, otherwise the alarm can never be cleared by the SOU occupant, thus the zone will always go into alarm. Also this firmware does not allow a heat detector to be mapped to an AAF zone.

8.17.3 Acknowledgement and Investigation Times

Operation of AAF uses an Acknowledgement delay and an Investigate delay.



The Acknowledgement and Investigate delay times must be agreed with the fire brigades and territorial authorities.

These delay periods are programmed into Zone profiles for use by the zones. It is possible to implement multiple profiles with different times, if required. Each zone uses the times programmed into its profile.



AS 7240.2-2004 Annex ZB specifies the maximum limits for each of these settings, and SmartConfig enforces these limits. Attempts to use time delays greater than that specified in AS 7240.2 will generate a warning.

When “Commissioning mode” is active, AAF time delays are reduced as follows, to allow testing to be done more quickly.

Acknowledgement delay in commissioning mode : 10 seconds.
Investigation delay in commissioning mode : 30 seconds.

If a zone is disabled or in alarm test, the AAF delays are not applied and the zone will go straight into alarm without any delay.

Overriding the AAF Delays

There are two ways that *MX1* can be configured to override the AAF delays and put a zone straight into alarm. This behaviour is identical to ADF behaviour and is described in section 8.25.4.

8.17.4 Configuration of AAF Zones.

Zones for which AAF operation is required must use a SmartConfig Zone Profile that enables AAF. These profiles use a Delay Type set to AAF, and have Acknowledge and Investigate times programmed.

The SmartConfig template has a default AAF zone profile, with default acknowledgement and investigate times. However, if different times are required, then it is recommended that new zone profiles be created by copying and pasting the supplied AAF profile, then changing the name and acknowledgment and investigation times, and make the zones use the new profile.

An AAF zone requires the following detection and I/O devices to be configured and mapped to or be controlled by the zone:

- One or more smoke detectors, with a suitable sounder base.
- AAM2 Alarm Acknowledgement module suitably wired to a MIM800 module.

Figure 8.12 shows the general arrangement of these devices. Configuration of the detection and I/O devices is described in the following section.

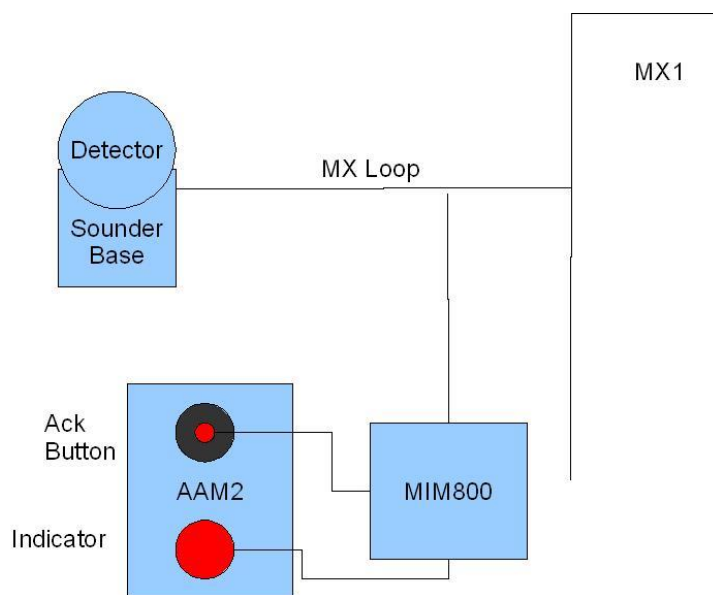

Figure 8.12 – Arrangement of AAM, MIM and Sounder Base for AAF

8.17.5 Detection Configuration for AAF Operation

Smoke detectors for an AAF SOU are mapped to the AAF zone. The smoke point must be configured for latching operation (with *MX1* V1.51 firmware) and non-latching for older versions of firmware.

For those detectors fitted to a sounder base, the functional base output must be enabled, and its O/P Control programmed to be **Zone**. If the sounder base is to form part of the occupant warning system, the functional base's O/P Control must be set to **Zone or Logic**, with suitable logic used to control the sounder base for the occupant warning system. For example, put \$ALARM_DEVICES_ON into the functional output point's Logic cell. Each SOU requires at least one MIM800 device wired to an AAM2 Alarm Acknowledgement Module.

The input point for the MIM800 must have its Point Type configured to be **Input Non Alarming**, the input be mapped to the AAF zone, have latching turned off, and use a profile with interrupts enabled. This configuration allows the zone to recognise the MIM800 input as the Acknowledgment control.

The LED output point for the MIM800 must have its O/P Control set to **Zone Secondary Control**, and then be mapped to the zone. This configuration allows the zone to control the MIM800 LED output as the AAF indication, which is operated as a secondary output in a different manner to the local sounders (primary output).

From SmartConfig V2.5.1.0 onwards, if 814PH or 850PH detectors are used, the smoke and heat sensors can both be mapped to the same AAF zone even though AAF is not to apply to the heat sensor as, by default, AAF will not occur on the heat subpoint.

8.17.6 Training Requirements

It is recommended that occupants of SOUs with AAF are trained in its operation. It may be necessary for the system designer to provide assistance in this training.

8.17.7 AAF Operation with no Alarm Acknowledgement Facility

Some sites may specify AAF operation but not include an AAF module for acknowledging the alarm. Thus there is only 1 delay period during which an SOU occupant must clear smoke from the smoke detector. The local sounder operates during the delay and turns off when the occupant clears the smoke. If the delay times out with smoke still present the *MX1* enters the alarm condition.

This is now called an Alarm Delay Facility (ADF). Refer to Section 8.25 for details.

8.18 Fire Fan Control (AS 1668) Applications Using Pushbutton Fire Fan Controls

8.18.1 Introduction

The *MX1* can be used as an AS1668.1 Fire Fan Control Panel (FFCP) to control and indicate smoke control systems within a building. Up to 126 controls can be fitted per panel, when using the FP1056 Fan Control Door and FP1057 Fire Fan Expander Kits. QIO850 or MIO800 modules can be used to interface to the Mechanical Services Board (MSB).

Based on the Distributed Switch System (DSS) framework, fire fans can also be controlled and indicated across a Panel-Link network, providing replicated FFCP in security rooms, backup fire response stations, etc.

The *MX1* Fire Fan Controls have been assessed to the functional requirements of AS 4428.7-1999 Fire Detection, Warning, Control and Intercom Systems – Control and Indicating Equipment – Air-handling fire mode control panel.

Refer to Section 8.19 for AS 1668 Fire Fan Control applications using the obsolescent ME0472 controls and indicators.

Refer to Section 8.23 for more details of the DSS, which provides the framework for the *MX1* AS1668 Fire Fan Control application. This detail may be used for more advanced configurations.

8.18.2 Supported Fan Control Configurations

The *MX1* FFCP uses the FP1056 AS 1668 Fire Fan Control Door to provide up to 12 fan controls per door (Figure 8-13). Each FP1056 is 3U high, comes with 2 controls fitted, and up to 5 x FP1057 Fire Fan Expansion kits can be added (each kit providing an additional 2 controls) (Figure 8-14).

Additional FP1056 doors and FP1057 expansion kits can be added, up to a maximum of 126 controls per *MX1* panel.

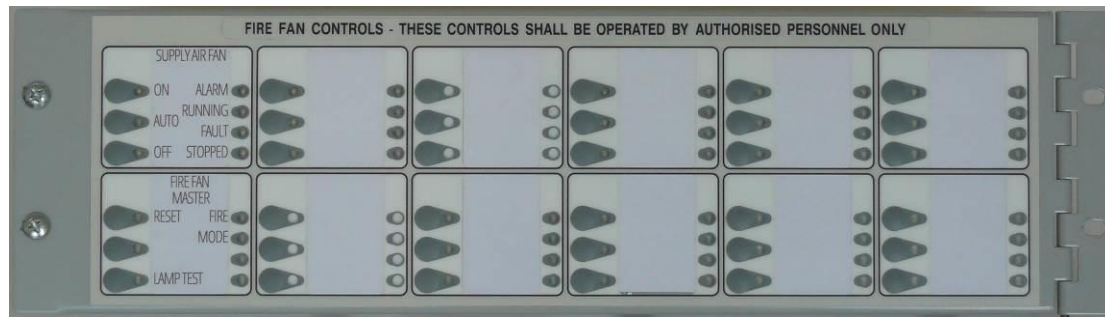

Figure 8-13 – MX1 Fan Control Door



Figure 8-14 – MX1 Fan Control Expansion Kit

Each control consists of:

- 3 buttons to control the fan or damper operation. Pushing a button selects its associated ON / AUTO / OFF or NON-FIRE / AUTO/ FIRE position, which is indicated by a corresponding green LED. The LED associated with the pressed button flashes briefly until the system has confirmed the new position.
- 4 Indicators - two red LEDs, one yellow LED and one green LED. One red indicator is available to indicate an alarm on the corresponding duct or compartment for Supply or Return Air fans. The remaining red, yellow and green indicators show the RUN, FAULT and STOP status of the fan, respectively. Dampers would not usually have a status indication.
- 8 programmable labels, one of which names the associated fan or damper, and 7 others which name the assigned function for each of the buttons and indicators.

In an FFCP one control must be designated as the Fire Mode Control. On this control the indicators are used to indicate that the FFCP is in Fire Mode, the buttons provide the mandatory Fire Mode Reset and Lamp Test controls, and one output can be assigned as the Fire Trip output. The configuration of this control is also necessary to integrate the *MX1* common fire alarm into the FFCP Fire Mode, to have Fire Mode indicate on the *MX1* keypad Smoke Control Activated indicator, and integrate any fire fan faults and fire fan main power faults into the *MX1* for annunciation.

Otherwise, each control is freely assignable as to its function. Any fitted control may be a fan, a damper, or the Fire Mode control. This allows for flexibility in placement of the controls on the front panel to suit the specific installation. Non-fire fan functions may also be configured, but care must be taken to ensure segregation between fire fan and non-fire fan controls. Refer to Section 8.23.

Labelling of the fan controls is provided by slip-in labels, which may be printed directly from SmartConfig, or from a Word label template (LT0590). The default text height of 5mm meets the requirements of AS 1668.1. The name of each fan control can be programmed, and each button and indicator has default names programmed which can be adjusted as required.

All physical fan controls for an *MX1* panel must be located in one or adjacent cabinets. An FFCP cannot be remotely wired to its *MX1* as the FFCP cabling is not designed for this purpose.

If an FFCP must be located remotely from the *MX1* driving the mechanical services board (MSB), then another *MX1* panel is required to drive the remote, duplicate FFCP and the *MX1* panels are networked together using Panel-link. When duplicate controls are used on a network, having physical controls on the panel connected to the MSB is usual, but not mandatory.

This technique also allows duplicate/replicated fan controls or installations where the FFCP is located separately from the *MX1* that interfaces to the MSB.

Interfacing to a fan unit requires half of a QIO850 module, or one MIO800 module. These modules must be mounted inside, or co-located beside the MSB cabinet. This ensures the supervision via the *MX* Loop extends up to the MSB interface.

The QIO850 provides 4 clean contact inputs and 4 relay outputs, and can interface with 2 fan units. The 'alarm' status of a pair of inputs is suitable for sensing one fan's Run status and Fault status (if provided). A pair of outputs is suitable for driving one fan's Run and Stop control inputs.

The MIO800 provides 3 clean contact inputs, the 'alarm' status of each is suitable for sensing the fan's Run status and Fault status (if provided). It also provides 2 relay outputs, suitable for driving the fan's Run and Stop control inputs.

Other suitable input modules, such as the MIM800 or CIM800, may be used, for example to interface to the equipment monitoring the fan power status.

Note that wiring faults on the *MX* loop or in the wiring between the I/O modules and the MSB will be annunciated on the *MX1* panel and not on a fan control fault indicator.

As the FFCP and fan control system is expected to operate during a fire, it is necessary that the detection and control wiring complies with the requirements of AS1668.1. This will usually require fire resistant cabling, often using a second loop card to separate detection wiring from fire fan control and detection wiring.

For specialised applications, the FFCP may be configured to use zones, logic variables or network variables for fan I/O function, however care is required to ensure a robust design. Consideration must be made for any delays, multiple sources of faults, effect of network delays and network faults, for example.

The standard *MX1* Templates contains predefined Output Logic and Logic Substitutions to make it easier to create AS1668 Fan Controls.

The new Fan Control Logic Blocks provided in SmartConfig simplify creation of different types of fan controls, and will, as necessary, automatically disable any existing System Logic used for the ME0472 Fan Control Solution.

8.18.3 FFCP Hardware Configuration

In most situations a 15U or other rack cabinet based *MX1* panel will have physical controls based on FP1056 doors (comes with 2 controls fitted, 12 controls maximum) and additional FP1057 expansion kits (adds another 2 controls).

The number of fans and dampers required will be derived from the installation drawings and any fan control matrix specified.

One additional control is required for the Fire Mode Control, and this may be on the same control PCB as a fan control.

Once the number of fan controls and doors are known, the cabinet configuration must be considered to ensure sufficient rack space is available.

Although an 8U *MX1* cabinet can mount a 3U door with 12 controls fitted, only the top row of 6 controls is visible through the door window. See Figure 8-15.

A 15U *MX1* panel with a keypad can mount up to 3 doors (36 controls maximum). If more controls are required, additional cabinets or larger cabinets can be used. For example, an empty 15U cabinet could house up to 48 controls, and a 40U cabinet with an *MX1* keyboard and ASE door can have up to 72 controls fitted, or an empty 40U cabinet can house 96 controls (see Figure 8-16) and still meet the indication and control restrictions of AS1670.1.

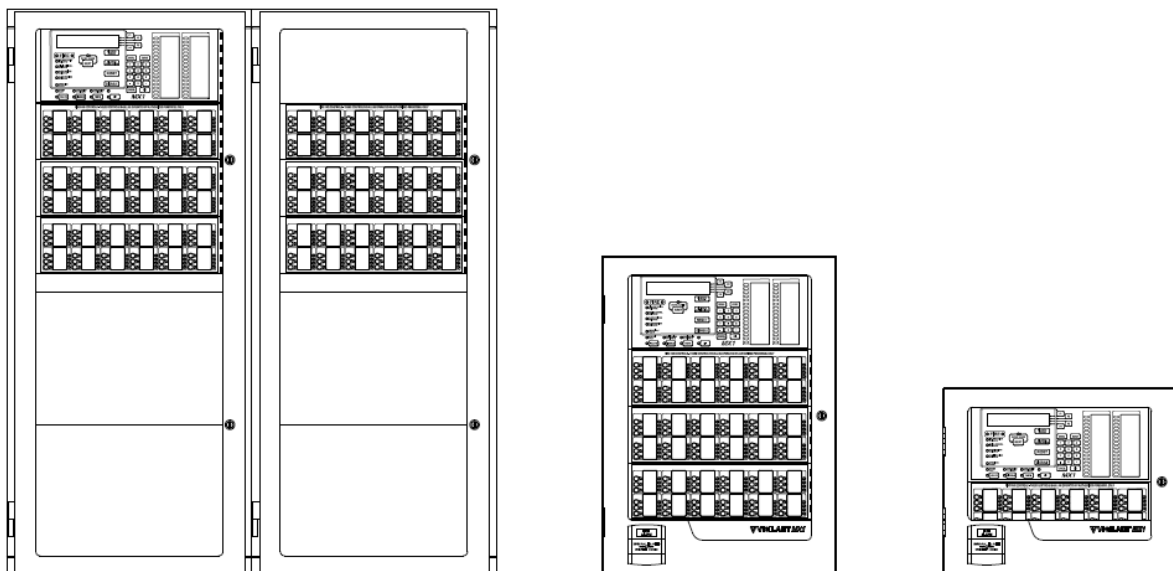

2 x 28U cabinets, 72 controls

15U cabinet, 36 controls

8U cabinet, 6 controls

Figure 8-15 – Rack Mounted Fan Control Doors

The FP1056 doors are bolted to the cabinet rack, and additional FP1057 expansion kit PCBs are screwed to the doors. Each fan control PCB is addressed with a unique odd number (on a DIP switch), being the number of the top control.

Controls on doors are usually wired to each other using a short FRC (LM0553) although a short Ethernet cable (LM0585) may also be used. Multiple FP1056 doors interconnect using an Ethernet cable (LM0583).

The fan controller PCB has a switch to enable the fan control master function. This function has the board act as the interface between the *MX1* Controller and rest of the fan control boards. There can be only one fan control master per FFCP on an *MX1* panel.

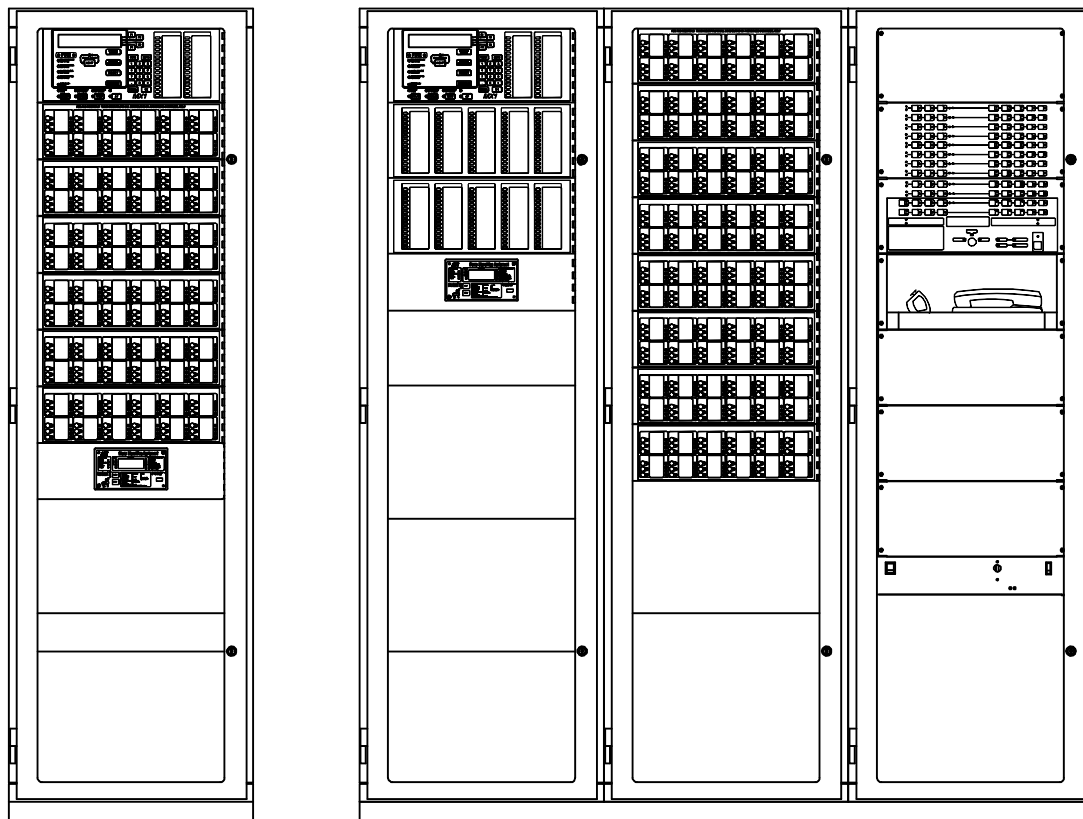

40U cabinet+plinth, 72 controls

40U cabinets+plinth, 96 controls, 192 Zone LEDs, QE90

Figure 8-16 – Rack mounted Fan Control Doors

The fan control master board connects to the *MX1* Controller for:

- 24V power, using LM0590 which includes a 5A fuse. If a different power cable must be used, a fuse of the same rating must be included. This power is then routed to the other fan control PCBs.
- Communication of button presses and status information from/to the rest of the FFCP. The master control communicates the indication status to the other fan control PCBs and collects button presses and monitors status. The connection to the *MX1* Controller is made using LM0324. This loom connects to the *MX1* Controller 10W serial port programmed in the SmartConfig database, either:
 - Directly to the 10W serial port, or
 - Indirectly via an *MX1* Loop Card connected to the programmed 10W serial port. The FFCP can be connected in series with up to 3 *MX1* Loop Cards.

Some installations may require co-located cabinets where no FFCP controls are mounted on the main cabinet containing the *MX1* Controller. If the connection between the *MX1* Controller and the fan control master cannot be made with the standard LM0324, then these installations require one additional FP1057 expansion kit PCB to be mounted within the main cabinet. This PCB is configured as the fan control master, which then uses an RJ45 cable to supply power and data to the fan controls in the other cabinets. This fan control PCB uses up 2 fan control positions, and must be programmed in the configuration even if it does not provide any useful I/O function.

Labels are fitted by sliding the labels into the slots on the rear of the door. Blank labels are fitted by default, and alternative pre-printed labels are supplied with each door and expansion kit. Customised labels can be printed from SmartConfig (Menu, File, Print Labels) or by using a Word template.

Full installation and diagnostic information is in LT0587 *MX1* Fan Control Installation Instructions.

8.18.4 Programming the Fire Fan Control Panel

The programming of the *MX1* FFCP is done using SmartConfig 2.5 or later, and uses features of the standard Australian Template V1.60 or later, including Fan Control Logic Blocks.



The standard *MX1* Fire Fan Controls Logic Blocks provide a simple solution for standalone FFCP, and network FFCP with duplicated FFCP controls. They will not suit all FFCP applications. Additional functions may require additional programming, or may require fully customised FFCP programming that does not use the Fan Control Logic Blocks. Examples of such functions are: “Take Control” or exclusive control; multiple FFCP systems with independent Fire Mode; systems that have separate *MX1* panels for FFCP detection, FFCP operation and FFCP I/O.

To configure a fire alarm system with fire fan controls, the normal building detection system must be programmed, plus the additional FFCP detection system and MSB interface loop(s) and device(s).

Firstly all the input and output points that provide interfaces to the MSB must be programmed. All inputs must be set non-latching. As the fans can and will change state as controlled by the MSB, the Run/Stop inputs should be configured with Point Flags of “No off normal”, and with a Logging profile of “Log Nothing”.

Output points must be configured for Logic control without any logic programmed (otherwise there are multiple equations controlling the outputs, which will function erratically). The outputs should use Point Flags of “No off normal”, and with a Logging profile of “Log Nothing”.

The I/O sub-points may be mapped to a zone that uses the No Alarm Annunciation profile, if signalling of faults to the monitoring service is desired.

The FFCP function itself is then programmed in two main steps:

1. Configure the FFCP hardware
 - a. Enable the connection to the physical doors and controls.
 - b. Configure any network operation, if duplicate controls are required.
2. Configure the FFCP Operation
 - a. Configure the controls themselves, using Logic Blocks.

8.18.5 Programming the FFCP Hardware

Programming of the FFCP hardware is made on the SmartConfig Hardware page, as shown in Figure 8-17.

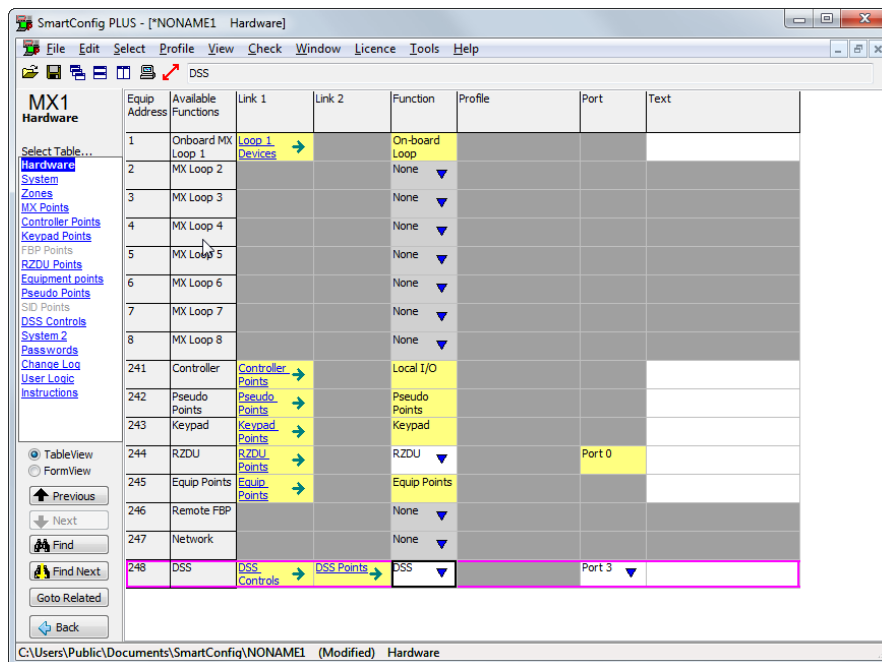

Figure 8-17 – SmartConfig Hardware Page

In most cases, the MX1 will have physical fan controls fitted, i.e., one or more FP1056 doors with the necessary FP1057 expansion kits.

The hardware is enabled by setting the Equipment 248 DSS Function to “DSS”. The correct communication port must be selected in the Port cell. The selected port may be shared with up to three MX1 Loop Cards.

When the Function is set to “DSS”, the MX1 will expect to use the programmed port to communicate with the board physically configured as the master Fan Control. The FFCP hardware will be configured using data created by the Fan Control Logic Blocks and stored in the DSS table. The configuration determines which controls should be present and how they should function. The MX1 also monitors the status of the FFCP and presents that status as DSS Status points 245.248.x, for communication faults, CRC faults and foreign control faults.

There may be cases where the physical FFCP is not present. An example would be a site with a remote FFCP networked to an MX1 that is exclusively interfacing to the MSB and is not normally accessible by a user. For these situations, the Equipment 248 DSS Function is set to “None”.

With the DSS function set to “None”, only the physical interface is non-functional. All internal operations based on the data created by the Fan Control Logic Blocks (DSS table entries, output logic etc.) will continue as programmed. The DSS Status Points 245.248.x will not be present in the system.

8.18.6 Programming a Network Fire Fan Control System

Networking must be enabled for *MX1* panels participating in a network FFCP system, e.g., Duplicate Fan Controls are present. Enabling of *MX1* networking is done on the Hardware page. See also Section 14 Networking.



If Duplicated Fan Controls are required on an *MX1*, networking must be enabled before any duplicate controls can be successfully programmed on any *MX1*.

By default a network *MX1* will send the status of its Primary Fan Controls onto the network. This is set by the System page “Send DSS Status to Network” setting being enabled. This can be disabled (if necessary) for network *MX1* panels with FFCP that do not require duplicate controls, to reduce network traffic.

The Fan Controls data is transferred as part of the Network Variables application, thus transfer of data for that application must be correctly programmed for *MX1* panels, I-HUBs, PIBs and other networking equipment. This requires that a local *MX1* must have a remote *MX1* panel in its SID list if:

- The local *MX1* has a Primary Fan Control mimicked on the remote *MX1* (permits the remote *MX1* to send button presses to the local *MX1*).
- The local *MX1* has a Duplicate Fan Control mimicking a Primary Fan Control on the remote *MX1* (permits the local *MX1* to receive control status from the remote *MX1*).

Network variables may also be used to share FFCP status and control amongst *MX1* panels, however consideration needs to be made in regards fault detection, network delays, etc.

Some network systems may require a function to have one FFCP ‘take control’ of the system and prevent other FFCP from controlling the system. The standard Logic Blocks do not support this operation, but the DSS Master Disable function may be utilised to implement such a function. Refer to Section 8.23 describing the DSS for more information.

8.18.7 Programming the Fire Fan Control Panel Using Logic Blocks

Programming the fan system is done by using the Fan Control Logic Blocks. These are accessed from within SmartConfig by using the Menu, Edit, Add Logic Block / Edit Logic Block / Delete Logic Block commands. See Figure 8-18.

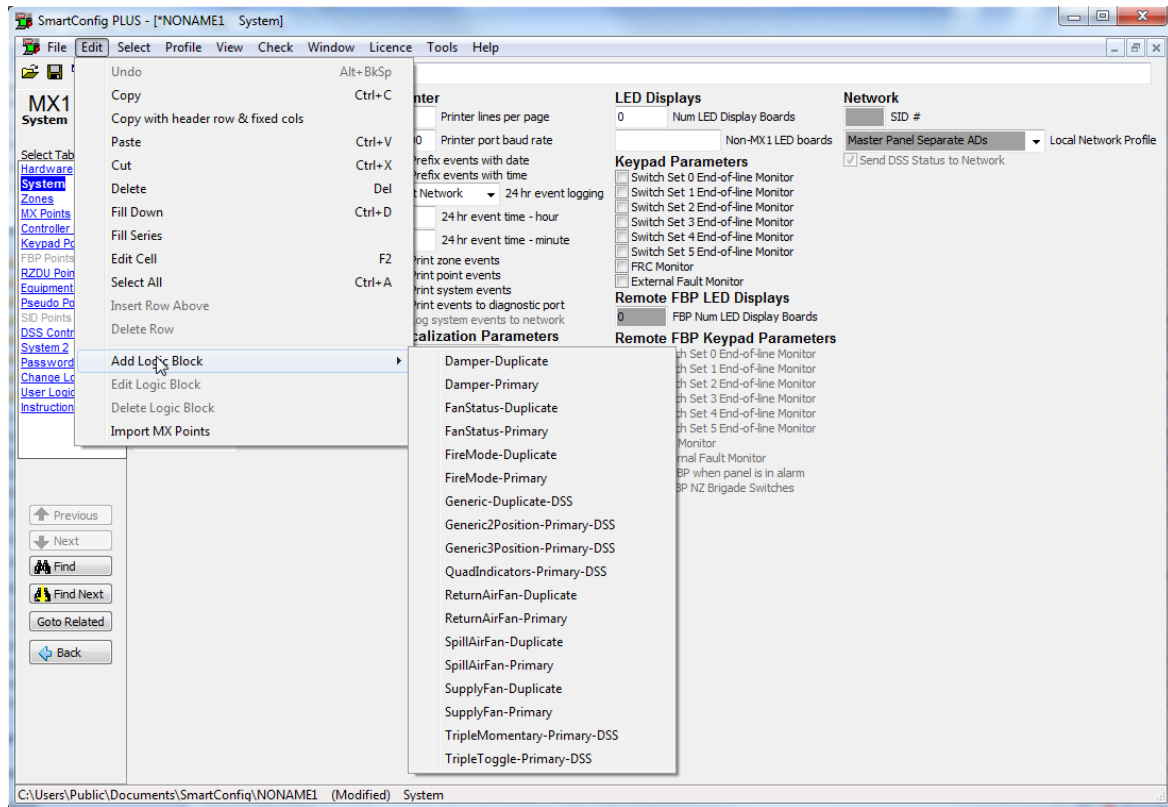

Figure 8-18 – Logic Blocks Menu Example

The Add Logic Block menu shows the available logic blocks. Click on the required Fan Control logic block. SmartConfig then presents a dialogue box requesting entry of the information required to program the fan control or damper control or Fire Mode control. See an example in Figure 8-19.

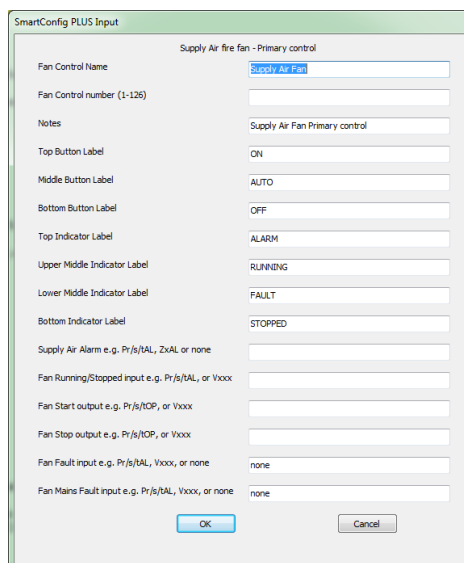

Figure 8-19 – Example Fan Control Logic Block

This example configures Control 1 for a Supply Air Fan function for Fan “AH1-12”, with the default labels. The Supply Air alarm (duct detector) is Zone 5. The fan run/stop status is the alarm status of input P1/57/1. The Fan Start/Stop outputs are P1/57/4 and P1/57/5, respectively. Input P1/57/2 signals a fan fault condition. For this fan there is no specific Mains Fault input.

In the logic block dialogue box a Fan Control number must be entered, along with any inputs and outputs necessary for monitoring or controlling the fan itself. All inputs and outputs are entered as Output Logic Tokens, e.g., combine the point number and a condition. Additionally, a set of default information is presented, for example label texts, that may be retained or overwritten.

When OK is clicked, the Logic Block automatically configures the control for its correct operation and labels, and programs the *MX1* Output Logic to perform the fan control IO functions. This output logic can be seen on the Menu, Profiles, Automatic Logic page (which is read-only).



Care is needed when entering information, as the data checking capability of the Logic Block system is limited.

The Logic Block entry prompts suggest what can be used as inputs and outputs, but no specific format checking or range checking is done. Labels are plain text entries. Control numbers, pseudo-point and timer numbers, and timer values must be numeric. Inputs and outputs are entered as if they were to be used in output logic, e.g. Z53AL, P1/2/1AL, P1/2/3OP or V100.



Any zones or points used must be correctly programmed before any logic block programming is done.

A blank entry in a new logic block will indicate mandatory information is required. For some entries (not all), a value of “none” is permitted and such entries will have “none” as their default value. Other entries, for the most part labels, have suitable default text preloaded.

If the data entered is incomplete, or if in some cases the data does not conform to expected formats, the logic block cannot be exited until valid data is entered or the screen is cancelled.

The data entered is not further validated until a Check Output Logic or Check Tables command is entered. Any errors will be displayed against the specific table the error is found in, thus the user may need to deduce the logic block that needs adjustment. Examples of this are: Invalid variable numbers, the use of unconfigured points and the use of input points as outputs, and vice versa.

If some aspect of the control requires adjustment, the Edit Logic Block command can be used. It recalls the originally programmed information and presents it in the same manner as the Logic Block screen. Changes can be made and the Logic Block can be re-saved.



Always use the Edit Logic Block command to update the Fan Control data. The Edit Logic Block command uses the data stored for a logic block, not the information it may have programmed into other *MX1* tables, such as the DSS table or Logic Substitutions table. Independent changes to such data will be lost when the Logic Block is edited and re-saved.

If a logic block is no longer required, the Delete Logic Block command can be used. This removes the functional logic and Logic Block settings.



At this time settings made to tables such as the DSS table and Logic Substitution Tables do not get deleted when a Logic Block is deleted. Some manual adjustments to the database may be required, for example programming the fan control to be “Disabled” in the DSS table.

Fan Control Logic Blocks are available in two classes:

- Primary – these program the *MX1* to perform all the fan functions locally on that *MX1* panel. This includes monitoring and indicating the fan status, controlling the fan, and responding to user input. These controls also ‘memorise’ the position of the ‘switch’. They can be successfully programmed for both standalone and network *MX1* panels.
- Duplicate – these program the *MX1* to monitor the state of a Primary control on another *MX1*. The states shown locally come from the monitored fan control over the network, and any local button presses are sent to the monitored fan control for processing. Duplicate Fan controls can be successfully programmed only if the *MX1* has networking enabled.

The following sections describe the Logic Blocks for the Primary Fire Mode Control, Primary Fans, Primary Dampers, and all Duplicate versions of those.

Programming the Primary Fire Mode Control

Each *MX1* FFCP requires a Primary Fire Mode Control. This section describes the Fire Mode Control Logic Block implementation. (Figure 8-20)

Figure 8-20 – Primary Fire Mode Control Logic Block



There can be only ONE Fire Mode Control (Primary or Duplicate) per *MX1*. Multiple Fire Mode Controls are possible, but only with customised programming.

Operationally, the Fire Mode Control manages and indicates the Fire Mode status of the FFCP, controls the optional Fire Trip output, and provides the necessary Fire Mode Reset and Lamp Test controls. It ensures the *MX1* FBP Smoke Control Activated indicator turns on. It also manages the AS4428.7 FIP Fault signalling, including the delay for signalling of an FFCP fault.

In most situations, the only data that needs to be entered is the control number to be used as the Fire Mode control, and the optional Fire Trip output.

All of the other settings, such as the labels, the pseudo-point used for fault signalling and the fault delay timing can be altered, but only if it is necessary or if the timer or pseudo point is required for some other function.

In the above example, Control 12 is the Fire Mode control, the default settings and labels are used, and there is no Fire Trip output programmed.

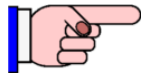

The primary Fire Mode Control will not permit a Fire Mode Reset as long as the Fire Mode Condition is TRUE. In most situations, the *MX1* will need to have all alarms reset and/or disabled to permit the FFCP to be reset out of Fire Mode.



The Primary Fire Mode Control will not permit a Lamp Test during Fire Mode.

Programming the Primary Fans and Dampers

SmartConfig provides the following Logic Block types for Primary controls:

- Supply Air Fan
- Spill Air Fan
- Return Air Fan
- Fan Status
- Damper

All options provide similar programming options, with minor differences as described further below. Each of the Primary Logic Blocks programs a fan or damper control for which all operation, I/O and memory of the control's switch position is local to the programmed *MX1*. A Spill Air example is shown below in Figure 8-21.

SmartConfig PLUS Input	
Spill Air fire fan - Primary Control	
Fan Control Name	Fan 10332-5 Spill
Fan Control number (1-126)	18
Notes	Spill Air Fan Primary control
Top Button Label	ON
Middle Button Label	AUTO
Bottom Button Label	OFF
Upper Middle Indicator Label	RUNNING
Lower Middle Indicator Label	FAULT
Bottom Indicator Label	STOPPED
Fan Running/Stopped input e.g. Pr/s/tAL, or Vxxx	P3/2/1AL
Fan Start output e.g. Pr/s/tOP, or Vxxx	P3/2/4OP
Fan Stop output e.g. Pr/s/tOP, or Vxxx	
Fan Fault input e.g. Pr/s/tAL, Vxxx, or none	P3/2/2AL
Fan Mains Fault input e.g. Pr/s/tAL, Vxxx, or none	P3/2/3AL

Figure 8-21 – Primary Spill Air Fan Logic Block

Operationally, the Fan and Damper Controls manage and/or indicate the status of the fans / dampers. The inputs and outputs programmed are used to generate fan status and to control the fans/dampers. The fan fault indication has options as described below. The fault indication for a fan is also used to drive the AS 4428.7 required fault signal on the panel.

In most situations, the data that needs to be entered is the fan name, the control number to be programmed, and the I/O needed for status and control.

Inputs should be Point or Zone alarm conditions, or variables, as required.

Outputs should be Point or Zone operate conditions, or variables, as required.

The labels are set to suitable defaults for AS1668.1 and for printing from SmartConfig, but may be adjusted. Note that if the labels are made too long, the labels for the buttons may overlap the labels for the indicators.

When not in Fire Mode (as determined by the Fire Mode Control), the outputs used by:

- the fan controls are determined by the control's switch position as follows:
 - ON: The Start output is ON, the Stop output is OFF.
 - AUTO: The Start output is OFF, the Stop output is OFF.
 - OFF: The Start output is OFF, the Stop output is ON.
- the damper controls are determined by the control's switch position as follows:
 - Fire: The Fire output is ON, the Non-Fire output is OFF.
 - AUTO: Both Fire and Non-fire outputs are OFF.
 - Non-Fire: The Fire output is OFF, the Non-Fire output is ON

When in Fire Mode (as determined by the Fire Mode Control), the outputs used by:

- the fan controls are determined by the control's switch position as follows:
 - ON: The Start output is ON, the Stop output is OFF.
 - AUTO: At most one of the Start and Stop outputs will be ON, based on the fan type and any supply air alarms. The other output will be OFF.
 - OFF: The Start output is OFF, the Stop output is ON.
- the damper controls are determined by the control's switch position as follows:
 - Fire: The Fire output is ON, the Non-Fire output is OFF.
 - AUTO: The Fire output is ON, the Non-Fire output is OFF.
 - Non-Fire: The Fire output is OFF, the Non-Fire output is ON

Supply Air Fan

A Supply Air fan is usually on, but turns on harder to increase air pressure when the system is in fire mode. It will turn off in fire mode if smoke is detected within the ducting system, based on the Supply Air Alarm condition, which is also indicated on the control. The fan can also be manually turned on and off.

If the Fan Fault input is set to "none", then during Fire Mode the control uses its fan output control state and its Run/Stop state to determine the fault condition.

If the Fan Mains Fault input is set to other than "none", that input is used in the fan's fault indication status.

Return Air Fan

A Return Air fan is usually running, but turns off when the system is in fire mode. It can also be manually turned on and off. If smoke is detected within the ducting system (the Compartment Alarm condition), this can be indicated on the control but does not affect the operation of the fan. The fan can also be manually turned on and off.

If the Fan Fault input is set to “none”, then during Fire Mode the control uses its fan output control state and its Run/Stop state to determine the fault condition.

If the Fan Mains Fault input is set to other than “none”, that input is used in the fan’s fault indication status.

Spill Air Fan

A Spill Air fan is usually off, but turns on when the system is in fire mode. It can also be manually turned on and off.

If the Fan Fault input is set to “none”, then during Fire Mode the control uses its fan output control state and its Run/Stop state to determine the fault condition.

If the Fan Mains Fault input is set to other than “none”, that input is used in the fan’s fault indication status.

Fan Status

A Fan Status control is used to indicate the status of a fan that is ‘linked’ to another fan. Its control buttons have no function as the fan operation is controlled by another fan control. One example of this are stairwell fans where two or more fans service a stairwell (and must be monitored) but only 1 control for all those fans is required.

For ‘linked’ fans, one fan control is programmed as a Supply, Spill or Return Air fan, and uses its one set of outputs to control the multiple fans through the MSB. That fan’s status is indicated on its control. The status of the other ‘linked’ fans is shown on their own Fan Status controls. Grouping of linked fans would be done by having all the controls similarly named and located physically together.

The Start/Stop outputs for a Fan Status control are programmed to be the same as for the fan control that is actually driving the outputs. These are used to allow the fan to determine its own fault status, as well as documenting the ‘as installed’ configuration of the system. Note that there is no crosschecking of these outputs to those used by the control driving the MSB.

If the Fan Fault input is set to “none”, then during Fire Mode the control uses its fan output control state and its Run/Stop state to determine the fault condition.

If the Fan Mains Fault input is set to other than “none”, that input is used in the fan’s fault indication status.

Dampers

Dampers are used by the Air Handling System to direct air from the ducting system to and from compartments within the building. During a fire, these dampers will open and close as required to control where air will flow. They can also be manually forced to their Fire or Non-Fire position.

Dampers have only outputs to be configured. There are no position or fault statuses to be indicated.

All of the other settings, such as the labels can be altered, but only if it is necessary.

Programming Duplicate Fire Mode Controls, Fans and Dampers

Duplicate Fan Controls are used to have a Primary Fan Control on one *MX1* be mimicked on one or more *MX1* panels across a Panel-Link network.



The Duplicate Fan Controls data is transferred as part of the Panel-link Network Variables application. Duplicates can only be programmed on a network *MX1*. Thus transfer of data for that application must be correctly programmed for *MX1* panels, I-HUBs, PIBs and other networking equipment.

SmartConfig provides the following Logic Blocks for Duplicate controls:

- Fire Mode Control
- Supply Air Fan
- Spill Air Fan
- Return Air Fan
- Fan Status
- Damper

A Duplicate Supply Air fan example is shown below in Figure 8-22.

A screenshot of the 'SmartConfig PLUS Input' dialog box. The title bar reads 'SmartConfig PLUS Input'. The main title is 'Supply Air fire fan - Duplicate control'. The dialog contains several input fields with labels and values:

Field Label	Value
Fan Control Name	Tower 5 Supply 17G29
Fan Control number (1-126)	34
Notes	Supply Air Fan Duplicate control
Duplicate Fan Control SID (1-250)	12
Duplicate Fan Control number (1-126)	8
Top Button Label	ON
Middle Button Label	AUTO
Bottom Button Label	OFF
Top Indicator Label	ALARM
Upper Middle Indicator Label	RUNNING
Lower Middle Indicator Label	FAULT
Bottom Indicator Label	STOPPED

At the bottom of the dialog are 'OK' and 'Cancel' buttons.

Figure 8-22 – Duplicate Supply Air Fan Logic Block

Each of the Duplicate Logic Blocks programs a local Duplicate Fan Control for which all operation, I/O and memory of the control's switch position is determined by a Primary Fan Control on another *MX1*.

In most situations, the data that requires entry is the fan name, the number of the local Duplicate Fan Control to be programmed, the SID number of the *MX1* the associated Primary Fan Control is programmed at, and the control number of the associated Primary Fan Control.

The labels are set to suitable defaults for AS1668.1 and for printing from SmartConfig, but may be adjusted. Note that if the labels are made too long, the labels for the buttons may overlap the labels for the indicators.

In the example above, Control 34 is configured to duplicate Supply Air fan "Tower 5 Supply 17G29", which is Control 8 on *MX1* SID 12. This control (34) uses the default labelling for buttons and indicators.

For the most part, a Duplicate Fan Control appears to operate exactly as the Primary fan control is programmed. Indications at the Primary Control appear on the Duplicate Control indicators. Buttons that do not work at the Primary Control also do not work at the Duplicate Control. Buttons pressed on a Duplicate Control are sent to the Primary Control for processing.

The Duplicate Fire Mode Control has some operational differences to the Primary Fire Mode Control it mimics. Firstly, the Fire Mode Control's Lamp Test performs that function at the local FFCP, NOT at the remote FFCP. Secondly, the Duplicate Fire Mode Control drives the local MX1 "Smoke Protection Activated" indicators, based on its mimicked Fire Mode indication.



There can be only ONE Logic Block based Fire Mode Control (Primary or Duplicate) per MX1. Multiple Fire Mode Controls may be possible, but only with customised programming.



Duplicate Controls should not be programmed to duplicate another Duplicate Control, as Duplicate Controls do not send status onto the network. At this time, SmartConfig cannot warn if this is done.



It is not possible to program two Duplicate controls on an FFCP to mimic the same Primary Fan Control.



It is not possible to program a Duplicate control on an FFCP to mimic a Primary Fan Control in the same FFCP.



The default logic creates a pseudo point 242.255.0 (AS1668 Common Fault) which will create a fault condition on the MX1 when any AS1668 control indicates a fault condition.

8.18.8 Fire Fan Control on XLGraphics

Version 7.15B or later of XLG allows the display and control of AS1668 air conditioning fans. The graphical representation of a fan control in XLG is shown below. Each of the three buttons on the left hand side is individually configurable in XLG for whether the operator is allowed to click that button or not.



A typical fan control screen in XLG would have a maximum of four rows of controls with six controls per row. A fan can appear on more than one screen. In XLG, the device library folder "MX1 DSS Controls" has pre-built controls for the following fan types.

1. Damper
2. Supply air fan.
3. Return air fan.
4. Spill air fan
5. Fan status

6. Fire mode
7. Generic 2 buttons
8. Generic 3 buttons
9. Generic 4 LEDs.

8.19 Fire Fan Control (AS 1668) Applications Using ME0472

8.19.1 Supported fan control configurations

The *MX1* can be used as a Fire Fan Control Panel (FFCP) to control and indicate smoke control systems within a building.

This section describes how this may be done using the obsolescent

ME0472 MX1 2U DOOR 4 X AS 1668 + COMMON CONTROLS

and MIO800 modules. The information presented here is retained for historical purposes and may be used as assistance for supporting systems providing fan controls in this manner.

See Section 8.18 for AS 1668 Fire Fan Control applications using the FP0156/FP1057 Fan Control Doors and Kits.



Figure 8.23 – ME0472 Controls & Indicators

ME0472 is a prebuilt 2U rack mounting panel fitted with 4 fan controls and indications, plus a common Fire Mode indicator, a Fire Mode reset control, and a lamp test control. The fan controls connect to the GP Inputs (J11) and O/C Outputs (J1) on the LCD/keyboard using the supplied flat ribbon cables.

Interfacing to a fan unit requires one MIO800 *MX* module. The MIO800 provides 3 clean contact inputs, suitable for sensing the fan's Run status and Fault status (if provided). It also provides 2 relay outputs, suitable for driving the unit's Run and Stop control inputs.

The standard *MX1* Australia Template contains predefined Output Logic and Logic Substitutions to make it easier to interface to the ME0472 and to create a fan control configuration. The substitutions are generally as follows, where x is the number of the fan control (1 - 4 from left to right when viewed from the front).

The following substitutions allow user logic to determine the switch position of each fan control.

- \$FAN_CONTROL_x_OFF
- \$FAN_CONTROL_x_AUTO
- \$FAN_CONTROL_x_ON

The following substitutions allow user logic to turn on the required indicator for each fan control.

- \$FAN_CONTROL_x_STOP
- \$FAN_CONTROL_x_FAULT
- \$FAN_CONTROL_x_RUN

The following substitution can be used in logic to drive fan indicators when the Lamp Test control is activated. Its function is inhibited when \$FAN_CONTROL_FIREMODE is true.

- \$FAN_CONTROL_LAMPTEST

The following substitution is for the reset pushbutton on the fan module. It is automatically used in `$FAN_CONTROL_FIREMODE` to exit fire mode, and can be used in other logic as a fire mode reset.

- `$FAN_CONTROL_FIREMODE_RESET`

The following substitution provides logic to drive the Fire Mode indicator when `$FAN_CONTROL_FIREMODE` is active.

- `$FAN_CONTROL_FIREMODE_INDICATOR`

The following substitution is used to determine whether the *MX1* fan controls should enter Fire Mode.

- `$FAN_CONTROL_FIREMODE_START`

The following substitution indicates when the FFCP is in fire mode, so that controls in the Auto position make the corresponding fan run or stop as appropriate. System Logic uses the states of `$FAN_CONTROL_FIREMODE_START` and `$FAN_CONTROL_FIREMODE_STOP` to control fire mode and turn on the smoke control indicator in the FBP.

- `$FAN_CONTROL_FIREMODE`

With a fan control in the Auto position, the *MX1* logic makes the corresponding fan run or stop as it must during a fire condition.

It also prevents `$FAN_CONTROL_LAMPTEST` becoming TRUE during fire mode.

8.19.2 Configuring *MX1* for Fan Controls

To add AS 1688 controls to a configuration, use the following steps:

1. Determine what conditions will put the fans into fire mode, and put these into the logic equation for `$FAN_CONTROL_FIREMODE_START`.
 - Example: to enter fire mode when any brigade calling alarm occurs
`$FAN_CONTROL_FIREMODE_START = CZBRALM`
2. Add into the user logic, on its own line, the substitution `$FAN_CONTROL_FIREMODE_INDICATOR`
 - This substitution, by itself, includes the logic necessary to drive the Fire Mode indicator.
3. For each fan to be controlled, configure an MIO800 module.
 - Input 1 (alarm) must be used for determining if the fan is running. Use a non-interrupt profile, no delays, and set to not latch.
 - Input 2 (alarm) must be used for monitoring the fan's fault status (if provided). Use a non-interrupt profile, no delays, and set to not latch.
 - Input 3 is available for other use.
 - Output 1 must be used for driving the fan's Start input, and be set for logic control.
 - Output 2 must be used for driving the fan's Stop input, and be set for logic control.
 - Set all Event Logging Profiles to None.
 - The point flags profile may remain as 'Standard' so that the MIO800 faults and disables are indicated, but the monitoring service will not be signalled.
 - The sub-points may be mapped to a zone that uses the **No Alarm Annunciation** profile, if signalling of faults to the monitoring service is desired.
4. For each supply air fan, configure the duct smoke detection devices and zones. The detector alarm condition must be non-latching, and a delay profile such as **Supply Air Shutdown** must be used. The zone must be non-latching.

5. For each fan control, add the necessary logic equations as detailed in sections 8.19.3 through 8.19.6. The logic equations selected will be based on the fan type (e.g. supply / spill / return).

An example of these equations is given in Section 8.19.7.

8.19.3 Fan Control Status Indication Equations

All fan types require the following equations to indicate fan status, where x is the number of the fan control to be used for the fan, and Py/z is the device number of the associated MIO800. Py/z/1 receives the fan running status, Py/z/2 receives the fan fault status (if available or used), Py/z/4 is the Fan Start output, and Py/z/5 is the Fan Stop output.

```
; Stopped indication  
$FAN_CONTROL_x_STOP = not Py/z/1AL or $FAN_CONTROL_LAMPTEST
```

```
; Running indication  
$FAN_CONTROL_x_RUN = Py/z/1AL or $FAN_CONTROL_LAMPTEST
```

For the fault indication, if the fan provides its own fault signal, use

```
; Fault indication  
$FAN_CONTROL_x_FAULT = (Py/z/2AL) or $FAN_CONTROL_LAMPTEST
```

For the fault indication, if the fan does not provide its own fault signal, use

```
; Fault indication  
$FAN_CONTROL_x_FAULT = ((not Py/z/1AL and Py/z/4OP) or (Py/z/1AL and Py/z/5OP))  
or $FAN_CONTROL_LAMPTEST
```

8.19.4 Supply Air Fan logic

A Supply Air fan is usually on, but turns on with increased air pressure when the system is in fire mode. It will turn off in fire mode if smoke is detected within the ducting system (the override condition). It can also be manually turned on and off.

For a Supply Air fan, use the following logic, where x is the number of the fan control to be used for the fan, Py/z is the device number of the associated MIO800, and <OVERRIDE> is a condition that should cause the fan to stop running - usually an alarm from a duct detector or zone. Py/z/4 is the Fan Start output, and Py/z/5 is the Fan Stop output.

```
; Start output - supply  
Py/z/4OP = $FAN_CONTROL_x_ON or ($FAN_CONTROL_x_AUTO and  
$FAN_CONTROL_FIREMODE and not <OVERRIDE>)
```

```
; Stop output - supply  
Py/z/5OP = $FAN_CONTROL_x_OFF or ($FAN_CONTROL_x_AUTO and <OVERRIDE>)
```

Note: if the Fan Control is in Auto, with Fire Mode not active and no duct detector in alarm (<OVERRIDE>), then both relays will be off.

8.19.5 Spill Air Fan Logic

A Spill Air fan is usually off, but turns on when the system is in fire mode. It can also be manually turned on and off.

For a Spill Air fan, use the following logic, where x is the number of the fan control to be used for the fan, Py/z is the device number of the associated MIO800. Py/z/4 is the Fan Start output, and Py/z/5 is the Fan Stop output.

```
; Start output - spill
Py/z/4OP = $FAN_CONTROL_x_ON or ($FAN_CONTROL_x_AUTO and
$FAN_CONTROL_FIREMODE)
```

```
; Stop output - spill
Py/z/5OP = $FAN_CONTROL_x_OFF
```

Note: if the Fan Control is in Auto with Fire Mode not active then both relays will be off.

8.19.6 Return Air Fan logic

A Return Air fan is usually running, but turns off when the system is in fire mode. It can also be manually turned on and off.

For a Return Air fan, use the following logic, where x is the number of the fan control to be used for the fan, Py/z is the device number of the associated MIO800. Py/z/4 is the Fan Start output, and Py/z/5 is the Fan Stop output.

```
; Start output
Py/z/4OP = $FAN_CONTROL_x_ON
```

```
; Stop output
Py/z/5OP = $FAN_CONTROL_x_OFF or ($FAN_CONTROL_x_AUTO and
$FAN_CONTROL_FIREMODE )
```

Note: if the Fan Control is in Auto with Fire Mode not active then both relays will be off.

8.19.7 Fan Control Logic Example

In this example, Fan 1 is a Supply Air fan which is controlled by MIO800 P1/17 and has a duct detector 814P P1/16, and Fan 2 is a Spill Air fan controlled by MIO800 P1/42. Both fans have a fault signal.

```
; The suggested equation is to use CZBRALM
$FAN_CONTROL_FIREMODE_START = CZBRALM
```

```
; Add Common Fan Control Logic
$FAN_CONTROL_FIREMODE_INDICATOR
```

```
; FAN 1 Supply Air
```

```
; Start output - supply
P1/17/4OP = $FAN_CONTROL_1_ON or ($FAN_CONTROL_1_AUTO and
$FAN_CONTROL_FIREMODE and not P1/16/1AL)
; Stop output - supply
P1/17/5OP = $FAN_CONTROL_1_OFF or ($FAN_CONTROL_1_AUTO and P1/16/1AL)
; Stopped indication
$FAN_CONTROL_1_STOP = not P1/17/1AL or $FAN_CONTROL_LAMPTEST
; Running indication
$FAN_CONTROL_1_RUN = P1/17/1AL or $FAN_CONTROL_LAMPTEST
; Fault indication
$FAN_CONTROL_1_FAULT = (P1/17/2AL) or $FAN_CONTROL_LAMPTEST
```

```
; FAN 2 Spill Air
```

```
; Start output - spill  
P1/42/4OP = $FAN_CONTROL_2_ON or ($FAN_CONTROL_2_AUTO and  
$FAN_CONTROL_FIREMODE)  
; Stop output - spill  
P1/42/5OP = $FAN_CONTROL_2_OFF  
; Stopped indication  
$FAN_CONTROL_2_STOP = not P1/42/1AL or $FAN_CONTROL_LAMPTEST  
; Running indication  
$FAN_CONTROL_2_RUN = P1/42/1AL or $FAN_CONTROL_LAMPTEST  
; Fault indication  
$FAN_CONTROL_2_FAULT = (P1/42/2AL) or $FAN_CONTROL_LAMPTEST
```

8.20 USING THE GP OUTPUTS

8.20.1 General

The MX1 Controller provides two general purpose open collector outputs, GPOut 1 and GPOut 2, that can have optional supervision of the load, or in fact be used as a supervised input if the output function is not required.

8.20.2 Outputs

The GP Outputs are rated at 500mA and +V max, so it is recommended any loads are powered from one of the +VBF terminals.

The output turns on when the corresponding output point is operated – as determined by the O/P Control setting. This allows the output to be controlled by a zone it's mapped to, or from user logic, or a combination of both, or from one of the predefined output logic substitutions (e.g., \$KEYPAD_FAULT_SOUNDER_ON).

8.20.3 Supervision Mode

The Supervision Mode of the corresponding supervision input point determines how the output is supervised. Suitable settings for outputs are:

- None: Output/load is not supervised.
- GP Out: Load is supervised for connection to +VBF – a fault is generated on open circuit, failure of the +VBF supply, or shorting the GP Out to 0V. As this does not provide short circuit fault detection when the GP Out is shorted to +VBF, it cannot be used for wiring external to the cabinet.

If the output function is not used the terminal can be used as a supervised input.

Figure 8.24 shows how a GP Out can be used for a supervised fault monitoring input (open or short is fault) to monitor normally closed or normally open fault contacts. Use the **Ext Fault Input- GP Out** profile, wire the 10k pull up to a +VBF terminal, and use a 2k7-4k7 end-of-line resistor.

By using a Points Flag Profile of **Map Fault to Brigade, No Test**, the fault state will be directly annunciated. Otherwise the point fault state could be used directly in User Logic, or via a suitably programmed pseudo point.

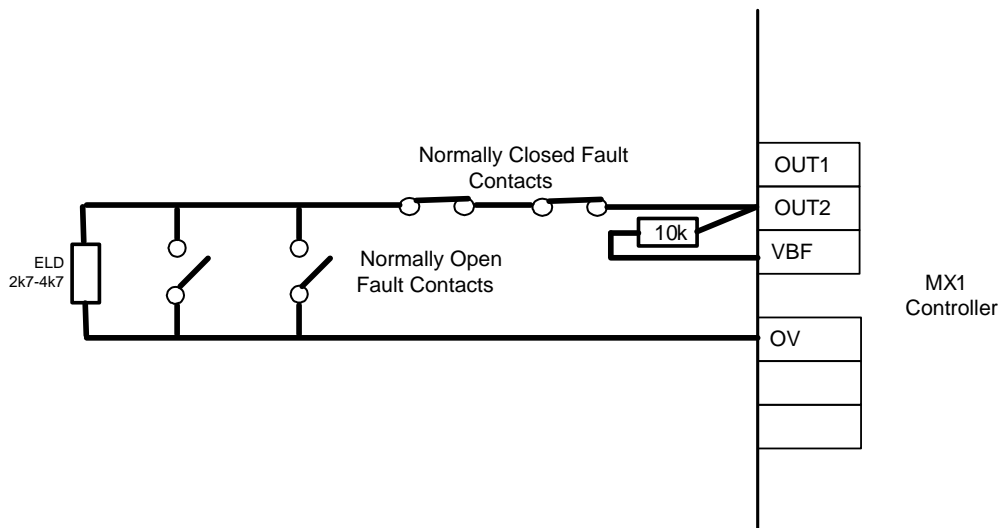

Figure 8.24 – Using GP Out Terminals for Supervised Fault Contact Inputs

8.21 USING THE LCD/KEYBOARD INPUTS & OUTPUTS

8.21.1 General

The LCD/keyboard provides 16 inputs and 16 open collector outputs that may be used for interfacing to other equipment.

Section 8.19 details a specific application where these inputs and outputs connect to the AS 1668 module to detect switch closures and control LEDs.

The following sections provide more general details on using these inputs and outputs.

8.21.2 Inputs

The inputs are two state – Normal when open and ActiveInput when closed.

Although the input points can be mapped to zones, this may not be directly useful as this just sets the zone’s ActiveInput state, which in most zone types does not exist.

Instead, the points’ AI states can be used in User Logic to directly control outputs (as in the AS 1668 example). Or the points’ AI states can be used to control the Alarm, Fault or Disable state of pseudo points. An example of this is shown in Section 8.6 Fault Monitoring.

The Inputs Connector J11 of the LCD/Keyboard may be wired to:

- A PA0479 16 Input Termination Board to provide protected input screw terminals, in which case the inputs may be cabled outside the cabinet.
- A PA0483 Unprotected Termination board for internal unprotected wiring.

8.21.3 Outputs

The 16 open collector outputs are normally off, turning on (< 100mA) according to the O/P control setting – allowing the outputs to be controlled by their mapped zone’s Operate state, a logic equation, or a combination of these.

The Output connector J1 on the LCD/keyboard could be wired to:

- A PA0470 16 way Relay board to provide clean contact outputs;
- A PA0480 16 way Protected Output board to provide protected outputs (diode clamp to +V and capacitor suppression) suitable for external load wiring;
- Or a PA0483 Unprotected Termination board for internal unprotected wiring.

The Relay board could be used to drive multiple alarm signals from the MX1 to a Grade 2 T-Gen2. Configure each LCD/Keypad Open Collector Output Point for an O/P Control of Logic and enter the logic equation to activate the output. For example.

P243/20/OOP = (Z1AL + Z2AL + ADT).^ADS

8.22 Additional Fused Power Outputs

The MX1 Controller provides 4 separately fused +24V battery-backed outputs - +VBF1, +VBF2, +VBF3 and +VRZDU. There is also a non-battery-backed output +VNBF. Each is fused at 3A and a fault is generated if the fuse blows or is removed.

If additional fused outputs are required there are two methods, both use the unprotected +24V Loop Interface Supply on J33:

1. By adding a fuse to J33 and wiring to loads (e.g., via LM0459) the Loop Interface Supply can be used to power Loop Cards, Remote FBP, or networking equipment.
2. By adding a 4100-KT0448 (PA0915) fuse board, 4 separately fused outputs can be provided. Mounting is available on the 15U gearplate for this – see Drawing 1982-71 Sheet 144.

For both methods the maximum load current permitted will be less than 5A, as determined by the PSU/battery ratings less all other loads.

Additionally, these fuses will not be specifically supervised for rupture/removal, so it is necessary to power only devices that are otherwise supervised by the MX1. For example, MX Loop Cards, T-Gen2, T-GEN 50, Remote FBP, and networking equipment.

8.23 MX1 Distributed Switch System (DSS)

8.23.1 Introduction

As of Firmware V1.60, the MX1 supports the Distributed Switch System, or DSS. The DSS provides a flexible switch and indication framework for local and cross-network fire related control and indication functions.

The DSS is the basis of the MX1 AS1668.1 Fire Fan Control Panel solution (See Section 8.18). It can also provide switches and indications for other application such as control of drain valves used for testing, deluge system tests, isolation switches, etc. By using the DSS network capability, switches and indications can be replicated between multiple MX1 panels.

The MX1 DSS provides 126 DSS controls, each of which may be used for fan controls or other functions and is configured as Disabled, Primary or Duplicate.

Disabled Controls have no function or operation. There should not be a physical control provided for Disabled controls, unless it is physically paired with an enabled control.

Primary Controls provide support for:

- 3 buttons which can be used for individual functions (momentary or toggle) or can be combined to provide one 2 or 3 position switch. The status of the switch is accessible via Output Logic to implement the desired system function. The buttons or switches can be programmed to remember their position (non-volatile) or not, whether the buttons can be pressed (Enabled) or not, and whether the buttons can be disabled at runtime (Master Disable). Buttons can also be programmed to be trapped for 'Special Functions' such as Lamp Test.
- 4 Indicators, the status of each is determined by Output Logic. Indicators with no logic equation are always off. The physical control has two red LEDs, one yellow LED and one green LED. Indicators can be trapped for 'Indicator Functions', which allow, for example, display of a common indication status.
- 8 freely programmable labels, one of which names the associated control, and 7 others which name the assigned function for each of the buttons and indicators. These labels can be printed from SmartConfig (Menu, File, Print Labels).

Duplicate Controls provide support for replicating a primary control on one *MX1* panel to one or more controls on other *MX1* panels:

- The SID number of the *MX1* panel and the Control Number that is being mimicked.
- 3 buttons, the status and configuration of which are sent by the control being mimicked. If a button is enabled by the control being mimicked, button presses are sent to the control being mimicked for processing. Buttons can also be programmed to be trapped for 'Special Functions' such as Lamp Test.
- 4 Indicators, the status and configuration of which are sent by the control being mimicked. The physical control has two red LEDs, one yellow LED and one green LED. Indicators can be trapped for 'Indicator Functions', which allow, for example, display of a common indication status.
- 8 freely programmable labels, one of which names the associated control, and 7 others which name the assigned function for each of the buttons and indicators. These labels can be printed from SmartConfig (Menu, File, Print Labels).

The DSS provides the button and indicator trapping functions which interface to Output Logic (allowing for Lamp Test or processing of common indication conditions), communication with and monitoring of any physical controls connected to the *MX1* (status indicated via DSS Status points 245.248.x), networking between the primary control and any duplicates, and support for "Master Disable" and "Lamp Test" Functions (within Output Logic).

Physical controls will usually be provided on a panel, but are not necessary.

For example, one panel could provide the physical I/O connections and thus the primary control, but have no physical control hardware present. Another *MX1* with physical controls (programmed as duplicates) networks to the original panel to provide a distributed system.

Note that if physical controls are provided there must be a physical control for every Primary or Duplicated control.

The DSS uses the FP1056 and FP1057 hardware for both the fan controls and other functions. Refer to Section 8.18 for details. Note AS1670.1 requires clear separation between fan controls and controls for other functions.

8.23.2 Programming the DSS

The programming of the *MX1* DSS system is done within SmartConfig 2.5 or later, and uses features of the standard Template V1.60 or later, including Logic Blocks for Fan Controls and General Purpose switches and indication.

The DSS functions are then programmed in two main steps:

1. Configure the DSS hardware
 - a. Enable the connection to the physical control doors

- b. Configure any network operation, if duplicate controls are required.
2. Configure the DSS Operation
 - a. Configure the controls themselves, using Logic Blocks.



This section uses the term DSS for the general switch system, and Fan Control for the specific use of the DSS for that application. In part, this is because the hardware is named for the Fire Fan application, as that is initially the main use for the DSS.

Some of the DSS programming is common with that of Fan Control programming, so is not repeated here. References are made to the relevant sections in Section 8.18.

8.23.3 Programming the DSS Hardware

Programming of the DSS hardware is made on the SmartConfig Hardware page, as described in Section 8.18.5.

Section 8.18.6 describes network programming of fan controls, which also applies to DSS use.

8.23.4 Programming the DSS Using Logic Blocks

Programming the DSS system is be done by using Logic Blocks. These are accessed from within SmartConfig by using the Menu, Edit, Add Logic Block / Edit Logic Block / Delete Logic Block commands. See Figure 8-25.

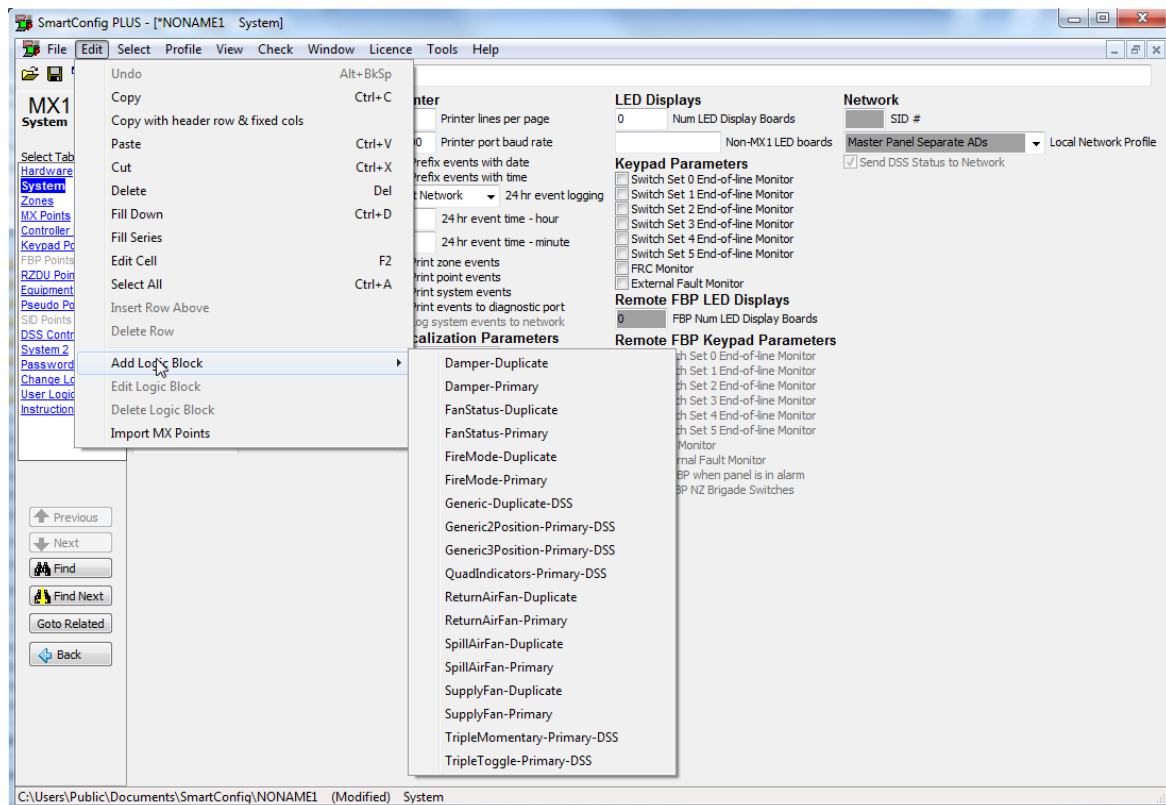

Figure 8-25 – Logic Blocks Menu Example

The Add Logic Block command shows the available logic blocks. Click on the required DSS function to open a dialogue box requesting entry of the information required to program a DSS control. The Logic Blocks that provide generic switch options (Figure 8-26), and direct programming of the DSS table are described in the following sections.

Generic 3 Buttons Momentary plus 4 Indicators - Primary Control	
Switch Name	Strobe Test
Control number (1-126)	85
Notes	Generic 3 Momentary 4 Indicators control
Top Button Label	Gantry Strobe test
Top Button Logic Output	P2/85/1OP
Middle Button Label	Welding Room Strobe test
Middle Button Logic Output	P1/8/2OP
Bottom Button Label	Dipping Plant Strobe test
Bottom Button Logic Output	P2/176/5OP
Top Indicator Label	
Top Indicator Logic	none
Upper Middle Indicator Label	
Upper Middle Indicator Logic	none
Lower Middle Indicator Label	
Lower Middle Indicator Logic	none
Bottom Indicator Label	
Bottom Indicator Logic	none

Figure 8-26 – Example DSS Logic Block

In all cases a DSS control number must be entered, along with the outputs to be controlled by the DSS Control buttons, and the inputs to drive the DSS Control Indicators. Additionally, a set of default information is presented, for example label texts, that will usually be deleted or overwritten.

In the example above, Control 85 (Strobe Test) is configured for 3 momentary pushbuttons, which are labelled with their functions and configured with the outputs to be activated when the corresponding button is pressed. Nothing drives the indicators, and thus the corresponding label texts have been deleted.

When the user presses OK, the Logic Block automatically configures the control for its correct operation and labels, and programs the *MX1* Output Logic to perform the DSS control IO functions. This output logic can be seen on the Menu, Profiles, Automatic Logic page (which is read-only).



Care is needed when entering information, as the data checking on entry of the logic block is limited.

The Logic Block entry system does not perform any format checking or range checking. Labels are plain text entries. Control numbers must be numeric and reference a valid control. Inputs and outputs are entered as if they were to be used in output logic, e.g. Z53AL, P1/2/1AL, P1/2/3OP or V100.

A blank entry in a new logic block will indicate mandatory information is required. For some entries (not all), a value of “none” is permitted and this is interpreted (variously) as the function is not required, the logic block must infer some function or an input does not exist. Such entries will have “none” as their default value. Other entries, for the most part labels, have a guiding text preloaded.

If the data entered is incomplete, or if in some cases the data does not conform to expected formats, the logic block cannot be exited until valid data is entered or the Logic Block is cancelled.

The data entered is not further validated until a Check Output Logic or Check Tables command is entered. Any errors will be displayed against the specific table the error is found in, thus the programmer may need to deduce the logic block that needs adjustment. Examples of this are: Invalid variable numbers, the use of unconfigured points and the use of input points as outputs, and vice versa.

If some aspect of the control requires adjustment, the Edit Logic Block command can be used. It recalls the originally programmed information and presents it in the same manner as the add logic block screen. Changes can be made and the Logic Block can be re-saved.



Always use the Edit Logic Block command to update the DSS Control data. The Edit Logic Block command uses the data stored for a logic block, not the information it may have programmed into other *MX1* tables, such as the DSS table or Logic Substitutions table. Independent changes to such data will be lost when the Logic Block is edited and re-saved.

If a logic block is no longer required, the Delete Logic Block command can be used. This removes the functional logic and Logic Block settings.



At this time settings made to tables such as the DSS table and Logic Substitution Tables do not get deleted when a Logic Block is deleted. Some manual adjustments to the database may be required, for example programming the fan control to be “Disabled” in the DSS table.

DSS Control Logic Blocks are available in two classes:

- Primary – these program the *MX1* to perform all the programmed DSS functions on the local *MX1* panel. Most Logic Blocks, other than “3 Independent Momentary”, ‘memorise’ the position of the ‘switch’. They can be successfully programmed for both standalone and network *MX1* panels.
- Duplicate – these program the *MX1* to monitor the state of a Primary control on another *MX1*. The states shown locally come from the primary DSS control over the network, and any local button presses are sent to the primary DSS control for processing. Duplicate DSS controls can be successfully programmed only if the *MX1* has networking enabled.

The following sections describe the Logic Blocks for the DSS Controls. See Section 8.18.7 for details of the Fire Fan Control Logic Blocks.

Programming the Primary DSS Control Logic Blocks

SmartConfig provides the following Logic Blocks for Primary DSS controls (controls for which the I/O is on this *MX1* panel):

- Generic3Position-DSS-Primary
- Generic2Position-DSS-Primary
- TripleMomentary-DSS-Primary
- TripleToggle-DSS-Primary
- QuadIndicators-DSS-Primary

These provide similar programming options, with minor differences as described below. An example of the Generic3Position-DSS-Primary logic block is shown in Figure 8-27.

SmartConfig PLUS Input

Generic 3 Buttons Momentary plus 4 Indicators - Primary Control

Switch Name	3 Momentary 4 indicators
Control number (1-126)	
Notes	Generic 3 Momentary 4 Indicators control
Top Button Label	TOP
Top Button Logic Output	none
Middle Button Label	MIDDLE
Middle Button Logic Output	none
Bottom Button Label	BOTTOM
Bottom Button Logic Output	none
Top Indicator Label	TOP
Top Indicator Logic	none
Upper Middle Indicator Label	UPPER MID
Upper Middle Indicator Logic	none
Lower Middle Indicator Label	LOWER MID
Lower Middle Indicator Logic	none
Bottom Indicator Label	BOTTOM
Bottom Indicator Logic	none

OK Cancel

Figure 8.27 – Primary 3 Position Switch Logic Block

Generic3Position-Primary-DSS

The Generic3Position -Primary-DSS Logic Block programs a DSS control to operate as a 3 position switch, with memory of its position that persists over *MX1* restarts. Its default position, if its memory is lost, is the centre/middle button being ON, the others OFF. The control also has 4 programmable indicators.

If the Button Logic is set to “none”, then there is no effect on the system, other than indicating the button is ON when pressed. Otherwise, the output specified will turn on and off dependent on whether the relevant button is ON or OFF.

If the Indicator Logic is set to “none”, then the indicator will remain off. Otherwise the indicator will turn on or off dependent on the Output Logic entered.

Generic2Position-Primary-DSS

The Generic2Position-Primary-DSS Logic Block programs a DSS control to operate as a 2 position switch, with memory of its position that persists over *MX1* restarts. The two positions use the top and bottom buttons, with the centre button being non-functional. Its default position, if its memory is lost, is the top button being ON, the others are OFF. The control also has 4 programmable indicators.

If the Button Logic is set to “none”, then there is no effect on the system, other than indicating the button is ON when pressed. Otherwise, the output specified will turn on and off dependent on whether the relevant button is ON or OFF.

If the Indicator Logic is set to “none”, then the indicator will remain off. Otherwise the indicator will turn on or off dependent on the Output Logic entered.

TripleMomentary-Primary-DSS

The TripleMomentary-Primary-DSS Logic Block programs a DSS control to operate as 3 independent momentary action switches. There is no switch memory. Each default position is OFF. The control also has 4 programmable indicators.

If the Button Logic is set to “none”, then there is no effect on the system, other than indicating the button has been pressed. Otherwise, the output specified will turn on for 1 second following the button press, and then OFF again. If the function requires a longer period than this, then output logic timers can be used to lengthen the switch ON time.

If the Indicator Logic is set to “none”, then the indicator will remain off. Otherwise the indicator will turn on or off dependent on the Output Logic entered.

TripleToggle-Primary-DSS

The TripleToggle-Primary-DSS Logic Block programs a DSS control to operate as 3 toggle action switches that can be turned on and off independently of each other. Each button has its own switch memory that persists over *MX1* restarts. The button’s default position is OFF. The control also has 4 programmable indicators.

If the Button Logic is set to “none”, then there is no effect on the system, other than indicating the button has turned on or off when pressed. Otherwise, the output specified will turn on and off to follow the button state.

If the Indicator Logic is set to “none”, then the indicator will remain off. Otherwise the indicator will turn on or off dependent on the Output Logic entered.

QuadIndicators-Primary-DSS

The QuadIndicators-Primary-DSS Logic Block programs a DSS control to have 4 programmable indicators. All buttons are non-functional.

If the Indicator Logic is set to “none”, then the indicator will remain off. Otherwise the indicator will turn on or off dependent on the Output Logic entered.

Programming Duplicate DSS Controls

Duplicate DSS Controls are used to have a Primary DSS Control on one *MX1* be mimicked on one or more *MX1* panels across a Panel-Link network.



The Duplicate DSS Control data is transferred as part of the Panel-link Network Variables application. Duplicates can only be programmed on a network *MX1*. Thus transfer of data for that application must be correctly programmed for *MX1* panels, I-HUBs, PIBs and other networking equipment.

SmartConfig provides the following Logic Blocks for Duplicate controls:

- Generic-Duplicate-DSS

A Generic-Duplicate-DSS example is shown below in Figure 8-28.

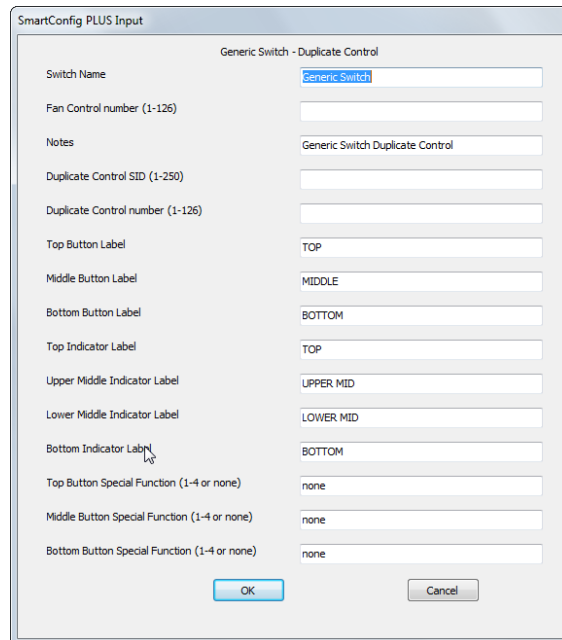

Figure 8-28 – Generic Duplicate Logic Block

The Duplicate DSS Block programs a local DSS Control for which all operation, I/O and memory of the control’s switch position is determined by a Primary DSS Control on another *MX1*.



Duplicate Controls should not be programmed to duplicate another Duplicate Control, as Duplicate Controls do not send status onto the network. At this time, SmartConfig cannot warn if this is done.



It is not possible to program two Duplicate DSS controls on one *MX1* to mimic the same Primary Fan Control on another *MX1*.



It is not possible to program a Duplicate DSS control to mimic a Primary DSS Control on the same *MX1*.

In most situations, the data that requires entry is the control name, the number of the local Duplicate DSS Control to be programmed, the SID number of the *MX1* the associated Primary DSS Control is programmed at, and the control number of the associated Primary DSS Control.

The labels are set to texts that identify the buttons and indicators, and should be adjusted as desired for printing from SmartConfig. Note that if the labels are too long, the labels for the buttons may overlap the labels for the indicators.

For the most part, a Duplicate DSS Control appears to operate exactly as the Primary DSS control is programmed. Indications at the Primary DSS Control appear on the Duplicate Control indicators. Buttons that do not work at the Primary DSS Control also do not work at the Duplicate DSS Control. Buttons pressed on a Duplicate DSS Control are sent to the Primary DSS Control for processing.

8.23.5 Programming the DSS Table

This section describes how to directly program the DSS using the DSS Table and Output Logic. This can be done if the Logic Blocks do not provide the necessary functions, or if, for example, a mixture of toggle and momentary buttons are required on one control.

The MX1 DSS Table provides for up to 126 DSS Controls per panel, which may (and usually will) have an associated physical set of controls. The available settings on the DSS table are shown below in Figure 8-29 (shown using “Form View” layout).

The screenshot displays the configuration interface for a DSS control. Key sections include:

- Index:** 9
- Switch Mode:** Primary
- Switch Operation:** 3 Independent
- Button Action:** Toggle (for B1A, B2A, B3A)
- Special Function:** None (for B1SF, B2SF, B3SF)
- Indicator Function:** I1IF, I2IF, I3IF, I4IF (checkboxes)
- Master Disable:** B1MD, B2MD, B3MD (checkboxes)
- Non-Volatile:** B1INV, B2NV, B3NV (checked checkboxes)
- Button Enable:** B1EN, B2EN, B3EN (checked checkboxes)
- Buttons:** B1L, B2L, B3L, I1L, I2L, I3L, I4L (input fields)
- Other:** Duplicate SID, Duplicate Switch, Notes field.

Figure 8-29 – DSS Table Settings for 1 DSS Control

Index

Every DSS Control is identified by a number, ‘Index’, which is used for its settings, its output logic tokens and matches the control number.

Switch Mode

The Switch Mode setting determines the basic switch function of the control. The basic switch functions have settings particular to each, and SmartConfig allows a user to program only those settings relevant to the switch function selected.

Unused: the control is not used in the system. No other settings can be updated. No physical control matching this Index should be present, unless paired with a control that is not Unused. No output logic should be written for an Unused control.

Primary: the control is used in the system, and its operation and status are maintained on the MX1 being programmed. Most settings are available to be programmed (partly determined by the switch mode), except for the Duplicate settings. The status of Primary controls is sent onto the network if networking is enabled AND the ‘Send DSS Status to Network’ setting on the System page is ticked (its default setting is ticked).

Duplicate: this setting is available only for MX1 panels that are networked. The control is used in the system being programmed, but its operation and status are maintained on the MX1 panel set in the control’s Duplicate SID settings. Thus settings related to Switch Operation, memory, button actions, etc., are unavailable. However, most other settings are available for local use.

Switch Operation

Primary switches use this setting to determine how the buttons on the control operate.

3 Position: The control is automatically configured for all 3 buttons to work together as a 3 position switch - if a button is pressed, it becomes the button that is ON and the others become OFF.

3 Position switches are useful for Fire Fan Controls.

By default a 3 button switch remembers its position through an *MX1* restart (Non-Volatile ticked), and all buttons can be pushed (Button Enabled ticked). These settings can be unticked if required (e.g. if a volatile switch is required, or if the button position needs to be viewed but not changed by pressing a physical button).

The default state for a 3 Position switch is the centre button ON.

2 Position: The control is automatically configured for the top and bottom buttons to work together as a 2 position switch – the centre button is not enabled, thus cannot be used. If the top or bottom button is pressed, it becomes the button that is ON and the others become OFF.

2 Position switches are useful for controlling drain valves or applications where an OFF/ON switch needs to be grouped with some associated status indications.

By default a 2 button switch remembers its position through an *MX1* restart (Non-Volatile ticked), and only the top and bottom buttons can be pushed (Button Enabled ticked for those, the centre button is always unticked). These settings can be unticked if required (e.g. if a volatile switch is required, or if the button position needs to be viewed but not changed by pressing a physical button).

The default state for a 2 Position switch is the top button ON.

3 Independent: The control is automatically configured for all 3 buttons to work as independent switches. How each individual switch works is controlled by the Button Action setting (Momentary or Toggle).

3 Independent switches are useful for providing Lamp Test and Fire Mode Reset support for an FFCP, applications requiring a large number of ON/OFF controls (such as plant isolate) or if a momentary action is required, such as triggering a timer controlled output.

By default a 3 Independent control is configured for 3 Momentary action buttons, with no memory (Non-Volatile unticked) and all can be pushed (Button Enabled ticked). These settings can be changed if required, e.g. if a toggle switch is required.



Note that a Momentary action button can never be Non-Volatile.



The default state for all buttons on a 3 Independent switch is OFF.

Switch Name, Button Labels and Indicator Labels

These fields are used to label the switch/control and its buttons and indicators.

SmartConfig uses these text fields when printing the DSS labels. The printouts use a standard font that will produce 5mm high text as required for AS1668 applications. If different heights and fonts are required then use the Word Template LT0590.

The texts also provide documentation for a programmer. The *MX1* itself does not make any use of these fields.



The text fields are configured to provide limits to the text lengths. Entry of a maximum length text does not guarantee the text will print properly. Reasons for this include: different characters have different widths; button labels and indicator labels occupy the same horizontal space, and may overlap if the texts are too long.

The Switch Name field permits entry of text up to 31 characters long. SmartConfig formats this for up to 2 lines of text.

The Button Labels and Indicator Labels allow for up to 13 characters of text. SmartConfig formats this for 1 line of text each. It does not check for overlaps of text. These will be evident when the labels are printed.

Non-volatile settings

The Non-Volatile settings determine which button(s) on the local control have their status remembered over a restart of the *MX1*. If unticked, the button(s) do not remember their state and revert to a default state determined by the Switch Mode and Switch Operation settings.

SmartConfig controls which settings are available, and which settings are inherently tied together based on the Switch Mode and Switch Operation settings. For example, a 3 button switch has only 1 user changeable setting which is applied to all 3 buttons.

All Switch types except Momentary action switches are Non-volatile by default.

Button Enable settings

The Button Enable settings determine which button(s) on a Primary Switch, and any Duplicates of that Switch, can be pressed. If ticked, the button can be pressed (and the physical control will indicate it has been pressed.) If not ticked, the button cannot be pressed (and the physical control will not indicate even if it is pressed).

SmartConfig controls which settings are available, and which settings are inherently tied together based on the Switch Mode and Switch Operation settings. For example, a 3 button switch has only 1 user changeable setting which is applied to all 3 buttons.

The Button Enable setting is used, for example, for the 2 Position switch to effectively stop the middle button from working. It may also be used to have a switch that the user cannot directly control using a button, but the status of which can be seen by the user and can be changed by suitable output logic.

Button Action settings

The Button Action settings are valid for only the 3 Independent Switches setting, and determine whether a button has a Momentary or Toggle action.

A Momentary Action switch turns on for 1 second and then turns off. An example usage would be for a Reset switch.

A Toggle Action switch turns on or off for each press. An example usage would be for a plant disable function.

Special Function settings

The Special Function settings determine whether a button on a control being pressed is treated as one of 4 Special Functions. If the setting is None, the button is not a special function, and thus is processed as normal. If the setting is SFX, then the button sets the

corresponding DSS-FUNCTION(X) logic token to TRUE for 1 second. No further processing or use of the button press is made. X can be 1 – 4.

This function is used by the Fire Fan Control logic blocks to implement the Lamp test Function. The Lamp Test button is captured for both Primary and Duplicate Fire Mode controls and sets a DSS-FUNCTION() token to TRUE, which then sets the DSS-LAMP-TEST token to TRUE to initiate the lamp test. Of particular note, the Duplicate Fire Mode control Lamp test button is captured for local processing, while the Reset button is sent across the network (as expected) to be processed at the Master Fire Mode control.

Duplicate SID and Duplicate Control settings

The Duplicate SID and Duplicate Controls apply only to Duplicate switches, and determine the remote *MX1* panel, and its control, that are to be duplicated locally.

The remote *MX1* and its control are where the programmed control gets its setup for its button from, its switch and indication status from, and where any buttons must be sent to for processing.

The remote *MX1* must have that control enabled, be networked, and be enabled to send DSS Status onto the network. The local *MX1* must be in the remote *MX1*'s SID Points table. Otherwise the duplicate control will not function correctly.

Master Disable settings

The Master Disable settings determine which button(s) on the local control stop being able to be pressed when the DSS-MASTER-DISABLE logic token is TRUE. The buttons still indicate their status, and the switch can still be controlled by other controls on the network, or output logic driving the Primary Switch. When the DSS-MASTER-DISABLE logic token is FALSE, the buttons return to their Button Enable controlled operation.

The Master Disable function, in conjunction with suitable buttons or keys, and network logic, may be used, for example, to control which of multiple FFCP on a network are able to be used at any one time.

Indicator Function settings

The Indicator Function settings determine whether indicator X on a control being ON contributes to set the corresponding DSS-INDICATION(X) logic token to TRUE for the longer of the indicator being on, or 1 second. The setting is ticked to have the indicator contribute.

X is 1 for the top red indicator, 2 for the middle red indicator, 3 for the middle yellow indicator and 4 for the bottom green indicator.

This function is used by the Fire Fan Control logic blocks to determine if there are any Fire Fan faults (yellow indicator on for Fan Controls) and if the Fire Fan Master is in fire mode (top red indicator) so the *MX1* Smoke protection indicator can be turned on.

Notes Field

This field allows for storage of any (short) useful information for this control.

8.23.6 Programming the DSS Output Logic

The DSS system interacts with the rest of the *MX1* via output logic, to implement the functions associated with the various controls and buttons.

There are logic tokens to read and 'press' the buttons, set the indicators on and off, signal the Special and Indicator functions, and send controls to any physical hardware for Lamp Test and Master Disable.

The Fire Fan Control and Generic Logic Blocks make extensive use of these tokens, and may be examined as examples.

Button Output Logic Tokens

The Button tokens are of the form SIPx/y. This translates to Switch Position for control x button y. 'y' is 1 for the top button, 2 for the middle button and 3 for the bottom button.

When used as a Right Hand Side token, as part of a logic equation, this token is TRUE if the corresponding button is ON.

For example $V10 = SIP14/2$ will set Variable 10 be true if the middle button on control 14 is ON.

When used as a Left Hand Side token, the corresponding button acts as if it has been pressed when the logic equation result is TRUE. Depending on the Switch Configuration, this may set a 3 position switch to the specified position, or change the status of toggle switch.

For example $SIP8/1 = P1/2/1AL$ will have control 8 respond as if button 1 had been pressed when P1/2/1AL is TRUE.

Indicator Output Logic Tokens

The Indicator tokens are of the form SIIx/y. This translates to Switch Indicator for control x indicator y. 'y' is 1 for the top indicator, 2 for the upper middle indicator, 3 for the lower middle indicator and 4 for the bottom indicator.

When the logic equation driving the SII token is TRUE, the corresponding indicator is turned ON.

For example $SII43/4 = P3/5/2AL$ will make control 43 turn on Indicator 4 when P3/5/2AL is TRUE.

Special Function and Indicator Function Logic Tokens

The Special Function token, DSS_FUNCTION(x), can be used to initiate actions when a particular button is pressed. While a similar operation could be implemented using the specific button's SIP token, the Special Function allows for multiple buttons to perform the function, or logic to be written without knowing exactly which button will be used. The Special Function also allows the buttons to be captured for local processing, which is of particular importance for Duplicate Controls.

The DSS-FUNCTION(x) token goes TRUE for 1 second whenever a button configured for SFx is pressed.

One use for the Special Function token is to manage the FFCP Lamp Test operation.

The Indicator Function token, DSS_INDICATOR(x), can be used to initiate actions when indicator 'x' on a control is ON. While a similar operation could be implemented using the logic driving an indicator's SII token, the Indicator Function allows for the status of indicator 'x' on multiple controls to easily be combined to perform the desired action.

The DSS-INDICATOR(x) token goes TRUE when one or more Indicator 'x' programmed for the Indicator Function is on, with a minimum TRUE period of 1 second.

One use for the Indicator Function token is to combine multiple FFCP Fan Faults (as indicated by the yellow indicator) and use this signal to create an MX1 fault condition.

Lamp Test Logic Token

The DSS-LAMP-TEST token is used to trigger the lamp test function on the local DSS hardware.

The Lamp Test Function (turn on all LEDs) is triggered when the logic equation driving DSS-LAMP-TEST changes from FALSE to TRUE.

Lamp tests cannot be retrIGGERED while a Lamp test is in progress, and are not extended if the DSS-LAMP-TEST token is set TRUE longer than the DSS hardware's test period.

For example $DSS-LAMP-TEST = DSS-FUNCTION(1)$ causes the hardware to perform a lamp test when the DSS-FUNCTION(1) token becomes TRUE.

Master Disable Logic Token

The DSS-MASTER-DISABLE is used to trigger the Master Disable function on the local DSS hardware.

The Master Disable function, when active, has the DSS hardware ignore presses on all buttons programmed to obey the Master Disable signal.

For example $DSS-MASTER-DISABLE = N33/1$ has the local hardware disable buttons programmed as obeying Master Disable when network variable NV33/1 is TRUE. Panel 33 could be programmed to set this network variable TRUE whenever a user operates a switch to prevent users at other panels from pressing buttons (a "Take Control" function).

8.24 Application – Activate Relay on Zone Reset

A number of installations may need to activate a relay when a zone is reset. For example, beam detectors may require power to be removed so that they can be reset.

This can be achieved by having output logic operate an ACZ controlling a relay output or to operate the relay output directly.

The logic equation uses the Zone Reset token $ZnnnRE$, which goes true while a zone is being reset.

$Px/y/zOP = ZnnnRE$ - $Px/y/z$ is the relay, $Znnn$ is the zone being reset

$ZxxxOP = ZnnnRE$ - $Zxxx$ is the ACZ, $Znnn$ is the zone being reset



Do not use a point reset token to drive the relay. Most point resets are fleeting, thus the relay will not operate as expected.

8.25 Alarm Delay Facility - ADF

8.25.1 General

ADF is a nuisance alarm reduction tool that allows trained occupants in Single Occupier Units (SOUs) to delay an alarm being signalled to the fire brigade while they attempt to clear the source of the alarm. It is similar to AAF except that there is no acknowledge button or Alarm Acknowledgement Module (AAM) with ADF.

When a smoke alarm is detected in an SOU, local sounders operate, notifying occupants of the alarm. If an occupier determines the alarm to be a nuisance alarm (e.g. burning toast), they can attempt to remove the source of the alarm and clear smoke from the detector. If the detector alarm condition clears within the investigation period (default 300 seconds), then *MX1* does not enter the alarm state and the fire brigade is not called. If the detector remains in alarm throughout the investigation period, *MX1* enters the alarm state, notifies the monitoring service and activates the Alarm Devices.

The LED on a smoke detector mapped to an ADF zone latches on when the zone goes into full alarm. *MX1* allows a latching detector to be non-latching during the ADF time delay, but latches the alarm state (and LED) once the ADF zone has gone into full alarm.

A heat detector can be mapped to an ADF zone. The ADF time delay does not apply to the heat detector unless it is configured with “Heat AIF”. A CO detector that maps to an ADF zone has the ADF delay applied to it by default. A CO detector that should not have an ADF delay applied to it should be configured with a Point Type of “CO non AIF”.

8.25.2 ADF Delays



- The investigation delay time used with ADF must be agreed with the fire brigades and territorial authorities.

The ADF delay period is programmed into the ADF Zone profile. It is possible to implement multiple profiles with different times, if required. Each zone uses the times programmed into its profile. AS 1670.1 specifies the maximum limit for the investigation delay. SmartConfig enforces these limits. Attempts to use a time delay greater than that specified in AS 1670.1 will generate a warning.



- When “Commissioning mode” is active, the ADF time delay is reduced to 30 seconds, to allow testing to be done more quickly.
- If a zone is disabled or in alarm test, the ADF delay is overridden and the zone will go straight into alarm without any ADF delay.

8.25.3 Configuration of an ADF zone and Smoke Detector

1. The smoke/ CO sensor (sub-point) mapped to an ADF zone must be configured as latching (this is the default). This is so that the detector LED latches on after the zone goes into alarm.
2. The point type for the smoke sensor (sub-point) should be set to “Smoke” (default). If the detector point type is set to “Smoke Non AIF”, *MX1* will bypass the ADF time delay for that sensor and the zone will go into alarm immediately on alarm. Similarly, a CO sensor mapped to an ADF zone has the ADF delay applied to it by default, but can also be configured as “CO non AIF” for no delay.
3. Zones for which ADF operation is required must use a SmartConfig Zone Profile that enables ADF. An ADF Zone Profile must have Output Control set to “ADF” and Delay Type set to “ADF”. When Output Control is set to “ADF”, any primary (or secondary) outputs that are mapped to the zone will be activated when the zone is in a “First Alarm” state and will turn off when the zone goes into full alarm.

- An ADF zone must also have one or more sounder devices mapped to it. This could be the sounder base (e.g., 80DSB) of the smoke detector in the SOU or a separately addressable sounder base (P80SB). The sounder base sub-point should have its output control field set to “Zone” and be mapped to the ADF zone.

The SmartConfig *MX1* default template provides an ADF zone profile with the investigation time set to 300 seconds. If a different time is required, then it is recommended that a new zone profile be created by copying and pasting the supplied ADF profile, then changing the name and the investigation time delay.

8.25.4 Overriding ADF Delays

NOTE : The information below is written in terms of ADF but the operation for AAF is identical except that AAF has its own “Enable AAF Override” checkbox in SmartConfig.

MX1 can be configured to override the ADF delay, resulting in an ADF zone going straight into alarm if another alarm occurs on the local or on a remote panel. By default, other local or remote alarms do not cause the ADF delay to be overridden. There are two ways of configuring the overriding of an ADF delay as follows.

1. Tick the “Enable ADF Override” checkbox on the System page in Smart Config.
OR
2. Add a logic equation in user logic that sets the AAF-ADF-OVERRIDE logic token.

The “Enable ADF Override” checkbox

If the “Enable ADF Override” checkbox is ticked then the following applies, regardless of whether there is a logic equation for AAF-ADF-OVERRIDE or not.

1. An alarm on a local zone that maps to both the Alarms List and the Alarm Devices will cause an ADF delay to be overridden and *MX1* will also send an “AAF/ADF Override true” state in its MAF status on the network.
2. An alarm that maps to the Alarms List and Alarm Devices on a remote *MX1* that has its own “Enable ADF Override” setting enabled, will cause an ADF delay to be overridden on the local *MX1* panel if the remote panel and the local panel are in the same Alarm Devices group. The Alarm Devices group that a panel belongs to is configured in the Local Network Profile.

The AAF-ADF-OVERRIDE logic equation

If there is a logic equation for AAF-ADF-OVERRIDE then the ADF delay is overridden when the logic equation is true, in addition to the behaviour provided by the “Enable ADF Override” checkbox setting. AAF-ADF-OVERRIDE is intended for the situation where an alarm on a remote non-*MX1* panel (e.g. MX4428 / F3200) should cause an ADF delay on the local panel to be overridden.

For example, a remote panel (say SID 23) could be configured to set a network variable true if there is any non-isolated zone in alarm mapped to the Warning System as follows.

$NV5 = ZWA$

MX1 would have the following in its user logic.

$AAF-ADF-OVERRIDE = NV23/5$

MX1 also provides a logic token LOCAL-AAF-ADF-OVERRIDE that returns true when there is a local non-disabled zone in alarm that maps to the Alarms List and the Alarm Devices. This logic token is unaffected by the “Enable ADF Override” checkbox setting.

8.26 Application – Using D51MX Duct Sampling Unit

The AS 1603.13 compliant D51MX duct sampling unit is designed to detect smoke in the air passing through an air conditioning duct by extracting some air through a smoke detector installed inside the D51MX.

A 850P or 850PH smoke detector should be installed for use with the MX1. In SmartConfig the smoke detector needs to be programmed with a Profile of **Count Normal** for the smoke sub-point for use in the D51MX. Any other selection is not approved. This provides a nominal 8%/m obscuration alarm level.

The D51MX contains a **Vigilant 3626** R5 version of Termination PCB.

Connect the MX Addressable Loop into the **IN +V, -V** terminals and the outgoing loop to the **OUT +V, -V** terminals, when an 850P or 850PH detector is used with an MX1 panel.

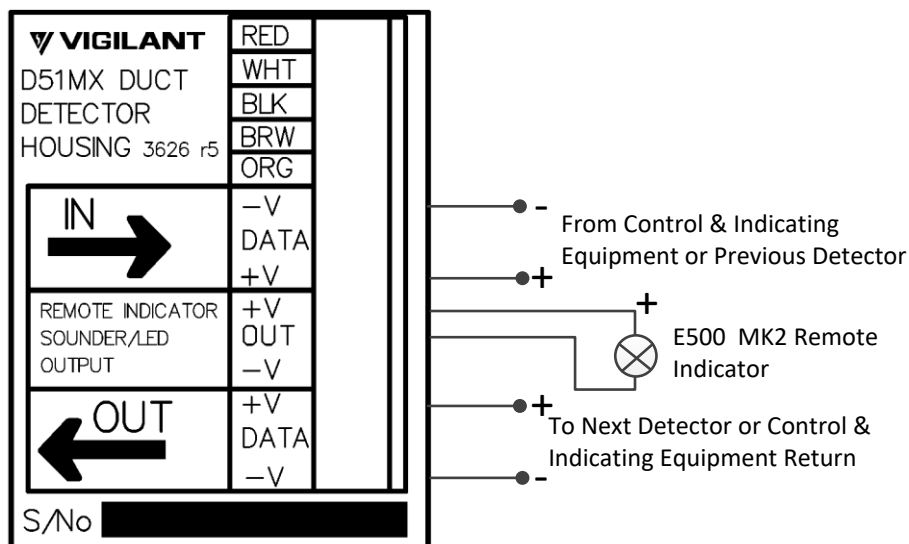

Figure 8-30 – D51MX with 850P/PH Field Wiring

8.27 External Strobe/Bell Silence with Alarm Buzzer Silence

8.27.1 General

Fire Alarm installations compliant with AS 1670.1 require an external alarm device (VAD) to alert the Fire Brigade to the location of the FIP. In some jurisdictions or in some upgrade situations, there may also be a requirement for an external sounder or bell. It is desirable that the Fire Brigade are able to turn this sounder off without having to silence the Alarm Devices (which is MX1 normal operation). MX1 can be configured so that the silencing of the alarm buzzer also turns off the external alarm device.

This can be achieved using the \$STROBE_WITH_ALARM_BUZZER logic substitution which is configured as a “Predefined Output Control” on the Logic Substitutions page. Because it is a predefined output control, it can be selected as the “O/P Control” setting for an output point.

Point (Equip 241)	Type	Point Desc	Zones	Pt Text	Alarm Type Text	Can be disab	O/P Control	Logic	Supervision Mode
9	ANC1S	Input		Anc1 Supervision		<input checked="" type="checkbox"/>			Contact ▼
10	ANC2	Output		External Strobe		<input checked="" type="checkbox"/>	\$STROBE_WITH_ALARM_BUZZER ▼		40020 Strobe ANC1 ANC2
11	ANC2S	Input		External Strobe Supervision		<input checked="" type="checkbox"/>			40020 Strobe ANC1 ANC2 ▼

\$STROBE_WITH_ALARM_BUZZER is true when \$STROBE_DRIVER goes true and the alarm buzzer is activated. When the alarm buzzer is silenced the strobe outputs turn off. If a new alarm occurs, the alarm buzzer will turn on again, and so will the strobe outputs.

The strobe outputs turn on only if there is an alarm in the alarms list that makes both the alarm buzzer and the Alarm Devices turn on. Thus the strobe outputs do not turn on if the Alarm Devices are disabled nor do they turn on for Auto-Reset testing.

The logic that SmartConfig generates for an output point that has output control set to \$STROBE_WITH_ALARM_BUZZER can be seen on the Automatic Logic page.

8.27.2 Zones that do not activate the alarm buzzer

There are some zone types, (e.g. sprinkler zones), which activate the Alarm Devices but do not turn on the alarm buzzer. These zones will not turn on the strobe output unless extra logic is added to make that happen. A logic equation can be written to include these zones as follows:

```
<strobe output> = $STROBE_DRIVER AND ($KEYPAD_ALARM_SOUNDER_ON OR ZxAL OR ZyAL ... )
```

Zones Zx and Zy are zones which activate the Alarm Devices but do not turn on the alarm buzzer. For zones other than Zx or Zy, silencing the alarm buzzer will still deactivate the strobe outputs. If an alarm occurs on Zx, Zy etc, the strobe outputs cannot be deactivated using the Silence Buzzer key.

NOTE - In some cases it may be appropriate to modify the zone profile for these zones so that "Map to Alarm Buzzer" is enabled, in which case there is no need for a customised logic equation to drive the strobe outputs.

8.27.3 Handling faults on strobe outputs

Strobe output points that have supervision enabled should be configured with a Point Flags Profile that signals fault to the Brigade – such as "Map Fault to Brigade".

8.28 Power Fail Output

8.28.1 General

Refer to Section 9.1.4.

9 PSU & Battery Design

9.1 PSU & Battery Design

9.1.1 General

This section describes the procedure of selecting a battery and power supply to meet the requirements of AS 1670.1 for a particular *MX1* system.

A reliable power supply for a fire alarm system is of the utmost importance as the successful operation of the whole system depends on it. The following calculations of power supply, battery and battery charger capacities must be performed in order to ensure that the fire alarm system meets the requirements of the local standards and codes.

These requirements are:

- A system must be able to run on its main power supply alone (no batteries) in the alarm or non-alarm condition.
- A system must be able to run on battery power (no main power) for 72 hours in the quiescent state, unless the system is monitored for power supply failure in which case the period can be reduced to 24 hours.
After this period, the system must be able to run on battery power in the alarm condition for 30 minutes.

The minimum PSU capacity to meet these requirements is based on three quantities:

- The current needed to charge the batteries in non-alarm operation.
- The current drawn by the *MX1* system and associated loads in the non-alarm condition (non-alarm load or NAL).
- The current drawn by the *MX1* system in a fire alarm condition (alarm load or AL).

The minimum battery capacity to meet these requirements is based on four quantities:

- The current drawn by the *MX1* system and associated loads in the non-alarm condition (non-alarm load or NAL).
- The current drawn by the *MX1* system in a fire alarm condition (alarm load or AL).
- The minimum specified time for non-alarm operation from the battery during a mains failure.
- The minimum required time for fire alarm operation from the battery.

Once the necessary battery capacity has been calculated, the battery charger capacity can be checked, based on these figures, plus:

- The maximum allowed time for the charger to recharge the battery.
- The maximum available battery charger current.
- The current drawn by loads powered from only the charger and not from the battery. This may include loads such as door holders.

9.1.2 MX1COST Calculation Tool

A software tool, MX1COST, is available for the *MX1* to make these calculations faster and easier, and to produce printed reports based on the local requirements.

MX1COST also checks the expected *MX* Loop performance. In general, the recommended approach is to use the latest version of MX1COST.

9.1.3 Mains Fail Fault

For databases initially created for MX1 V1.70 or later systems, a brigade fault is generated 90 minutes after mains power is lost, to comply with AS 1670.1. It is cleared 1 minute after mains is restored. There are two logic equations in the “Brigade Fault for Mains Fail” section of the User Logic that implement this functionality.

For databases initially created for MX1 V1.6x or earlier systems, these two equations are commented out and use a 24 hour timer. Upgrading such a database to V1.70 will not enable the equations. To have these upgraded systems comply with AS 1670.1, it is necessary to uncomment the two logic equations and change the TM999 timer value to 90, or as appropriate for the desired time delay between mains power fail and the fault being signalled.

9.1.4 Power Supply Fail Signal

AS 1670.1 requires a panel to provide a power supply failure signal when all power to the panel has fallen below the minimum operating voltage, to enable the standby battery capacity to be reduced to 24 hours.

As standard, the MX1 fire alarm provides this signal integrated with the fault relay. The fault relay is normally energised and becomes de-energised on a fault condition, which includes various power supply supervision faults. In the event that power fails completely, the relay de-energises thus signalling a fault.

However, in many circumstances a separate power supply failure signal is required, so it is necessary to use one of the other MX1 outputs.

Some options available are to use the ANC1 or ANC2 relays, or the GPOut1 or GPOut2 outputs perhaps driving a PA0730 relay board to provide a clean contact output.

In all cases it is necessary to write a logic equation for the output, that has the relay energised (output on) in the powered condition, and de-energised (output off) when there is a power supply failure.

For the given output X, the equation should be

$$X = \text{NOT } \$\text{SYSTEM_POWER_FAIL}$$

where \$SYSTEM_POWER_FAIL is a logic substitution for the fault state of the System Power Fail point P241/25/14.

For correct operation, the connection to the ASE / main FIP should be wired to use the relay contacts to produce a Power Supply Fail condition when the relay is de-energised (output off). The actual wiring, any EOL resistors, etc., is dependent upon the type of equipment supervising this output.

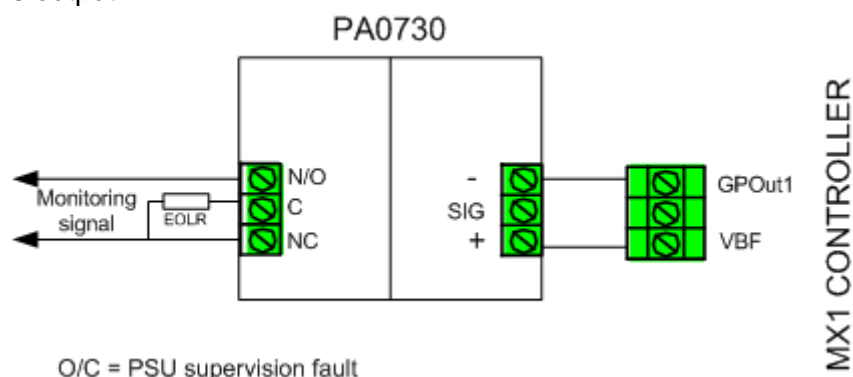

O/C = PSU supervision fault

Figure 9.1 – PA0730 Relay Board Wiring

9.2 Manual Battery Calculation – System Loads

The following instructions allow a system designer to manually calculate PSU and battery sizes. The calculations for battery and PSU sizes are based on conservative figures, particularly in regards some alarm loads.

A more detailed calculation can be obtained by using MX1Cost, which permits more specific installation information to be used.

Refer to Chapter 6 for details of the *MX* Loop load calculations. From these calculations add up the NAL Total Loop Battery Load (Non-Alarm Load) and the AL Total Loop Battery Loads (Alarm Load) for each of the loops into the right hand cells of the first row of the following table. Put the number of the *MX* loop cards in the quantity box on line 5 and multiply the Individual NAL and AL currents to give the collective NAL and AL currents (put into the right hand side boxes).

Do the same for each of the following pieces of equipment that can be used. Note that the currents for T-Gen 60 and T-Gen 120 presume maximum power output of 60W and 120W, respectively. The currents may be reduced pro-rata based on the actual speaker loads (if known). Any T-Gen2 strobe load must be included as Additional Battery Loads.

Enter the NAL and AL values for any other battery loads not already accounted for in the final row. Additional battery loads will include optional items such as VLC800MX detectors, printers and RDU devices powered from the *MX1* supply, plus loads switched on in alarm – like SNM800 and 901SB sounder bases, and strobe outputs on T-Gen2. Sum the NAL and AL columns to produce the system total battery loads.

	Quantity	Individual NAL (mA)	AL (mA)	Collective NAL (mA)	AL (mA)
Total Loop Battery Loads (from <i>MX</i> Loop calculations)					
Controller Bd				120	150
LCD/Keyboard				30	140
Zone display board allowance				16	56
<i>MX</i> Loop Card		70	70		
T-Gen 60 (0, 1, 2 or 3)		170	3000		
T-Gen 120 (0 or 1)		170	6000		
100V Splitter Module		15	15		
100V Switching Module		10	10		
T-GEN 50 (0 or 1)		64	2200		
Mini-Gen (0, 1, or 2)		0	1200		
I-HUB		100	100		
OSD Fibre Modem		15	15		
PIB		35	35		
Moxa Switch (fibre)		320	320		
Moxa Switch (Ethernet only)		260	260		
Ethernet Extender (DDW-120)		110	110		
Centaur ASE (0 or 1) if powered from <i>MX1</i>		50	50		
Remote FBP		180	180		
AS1668/DSS Control Bds		8.5	8.5		
Additional Battery Loads					
Total Battery Loads					

Calculate the non-battery-backed load currents drawn directly from the charger:

		Individual	Collective
	Quantity	NAL (mA)	NBL (mA)
24V door holders		50	
Additional Non-battery Loads			
Total Non-battery Load (NBL)			

If there is a non-battery-backed load in alarm (unusual) then this figure must be calculated and is NBAL.

9.2.1 Battery Capacity Calculation (AS 1670.1)

Sections 3.15.4 and 3.15.6 of AS 1670.1 specify the calculation methods for the PSU / battery charger capacity and the standby battery respectively.

Enter the total battery loads NAL and AL, and the non-battery load NBL calculated above in to the following table, and calculate the battery capacity BC and charger capacity CC using the equations given.

Note: If the actual settings are different, use *MX1COST* instead of this manual configuration.

For a system with monitored power supply failure:

Non-alarm load (from load calculation)	NAL =	<input type="text"/>	Amps
Alarm load (from load calculation)	AL =	<input type="text"/>	Amps
Non-battery load (from load calculation)	NBL =	<input type="text"/>	Amps

Minimum battery capacity

$$BC = (NAL \times 24 + AL) \times 1.25$$

= Amp-hours

Minimum power supply capacity

$$= NAL + NBL$$

= Amps

or (AL+NBAL)

= Amps

Take the higher of these two to determine the PSU capacity

= Amps

Otherwise:

Non-alarm load (from load calculation)	NAL =	<input type="text"/>	Amps
Alarm load (from load calculation)	AL =	<input type="text"/>	Amps
Non-battery load (from load calculation)	NBL =	<input type="text"/>	Amps

Minimum battery capacity $BC = (NAL \times 72 + AL) \times 1.25$
 = Amp-hours

Minimum power supply capacity $CC = NAL + NBL$
 = Amps
 or $(AL + NBAL)$
 = Amps

Take the higher of the above two
 to determine the PSU capacity = Amps

If the minimum charger capacity is 5.0A or less, the *MX1*'s internal charger will be sufficient. If not then refer to section 9.4.

9.3 Battery Housing

From the table below, find the smallest available battery that will meet the minimum capacity requirements from the above calculation or from MX1COST.

If the required battery is larger than will fit in the *MX1* cabinet being used, an external battery box located adjacent to the *MX1* cabinet, will be required to house the batteries. A remote battery box requires dual cable paths under AS 7240.2, which the *MX1* does not provide. The FP1029 battery box (550W x 440H x 180D) is suitable for housing 24V batteries to 40Ah capacity and greater.

Calculated Battery Capacity	8U Cabinet	15U Cabinet
12Ah	Internal	Internal
17Ah	Internal	Internal
26Ah	External	Internal
35Ah	External	Internal
40Ah	External	Internal

If an external battery box is used, an overcurrent protection device (e.g., 10A fuse) must be fitted at the battery terminals, preferably between the batteries, to protect against overheating and the risk of fires arising from short circuits in the battery wiring. A suitable loom is LM0571, which contains a 20A fuse.

9.4 Additional Charger and Batteries

A Grade 2 T-Gen2 installation requires a separate power supply. A Grade 3 T-Gen2 solution can be powered from a single shared supply, as per the *MX1* PSU. If a charger capacity greater than 5A is required for a system, an additional charger and battery will be required. The additional charger and battery should be used to power the external loads such as networking equipment, the T-Gen2s, T-GEN 50s, Mini-Gens, strobes, bells, etc., that would have been powered from a +VBF terminal on the *MX1* Controller.

The additional charger must be capable of performing the monitoring tasks such as checking for Battery Low, Charger High/Low, and Battery Connection and generating a fault output. It should also have an external Battery Test input to allow the *MX1* Controller to perform regular battery tests. The PSU2406F (ME0334 or ME0340) and PSU2412F (ME0343) are suitable units for this application under AS 1670.1:2015. A PSU compliant with AS 7240.4 needs to be used in systems to comply with AS 1670.1:2018. The 14A PSE (FP1139) should be used for T-Gen2.

The additional charger must be connected to the Controller as follows:

- The 0V of the charger and Controller must be connected. This connection does not have to carry load current, so does not need to be especially heavy. This is to allow fault monitoring and control of the charger by the Controller.
- The FAULT- output of the charger should be connected to one of the GP Inputs on the Controller. This input should be configured as an external fault input as described in section 8-6. On the PSU24xx set the charger fault output for open collector and fit the *MX1* GP Input 3K3 EOL resistor between pin 4 of J7 and 0V on the PSU.
- The BATTERY TEST- input of the charger should be connected to one of the GP Outputs on the Controller. A user logic equation is required to control this output from the logic tokens for automatic and manual battery test:

```
; Send Battery Test signals to the additional charger  
; Combine Automatic and Manual battery test tokens  
$GP2_OUTPUT = BTA OR BTM
```

The 0V terminals of each external load must be connected directly to the additional charger rather than the Controller. The +V terminal of each external load is connected directly to the additional charger (for T-Gen2 or T-GEN 50) or via an Ancillary Relay contact (for Mini-Gen, bells, strobes, etc.).

The Controller itself is powered from the *MX1* charger and a smaller battery, which has to carry the load of only the *MX1* and the *MX* Loop. Two sets of battery calculations must be carried out for a system with an additional charger and battery:

- the first calculation takes account of the *MX* devices on the loop, and the Controller and LCD/Keyboard loads. External loads are not included. This calculation will give the necessary size for the battery connected to the Controller.
- the second calculation takes account of the external loads, and ignores *MX* devices and Controller loads. If using *MX1COST*, set the numbers of all *MX* devices to zero, and subtract the quiescent and alarm loads of the Controller and LCD/Keyboard (166mA and 356mA respectively) from the external load totals. This calculation will give the necessary size of the additional charger and battery.

Possibilities of cabinets to house the extra charger and batteries are the:

- FP1029 battery box (550W x 440H x 180D) suitable for housing 24V batteries to 40Ah capacity and greater.

The stand-alone T-Gen2 BOWS and EWS products (FP1129, FP1144, FP1134 and FP1130) provide a solution for a large T-Gen2 system.

9.5 Powering from an External DC Supply

If 230V mains power is not available to power the *MX1* then an external DC power supply can be used instead.

The requirements for the external DC power supply are:

- Supply voltage: 24V to 28V
- Supply current: 6A
- Wiring fuse: 10A

The external DC power supply should be wired to the J14 PSU INPUT of the MX1 Controller. Cut the existing power supply lead to J14. Connect the orange wire (Pin 3, +VNB) and the red wire (Pin 4, +VB) together and to +24V of the external power supply. Connect the black wire (Pin 1, 0V) to 0V of the external power supply. Fit a 10A fuse at the external power source to protect against cable faults and overload. See Figure 9.2.

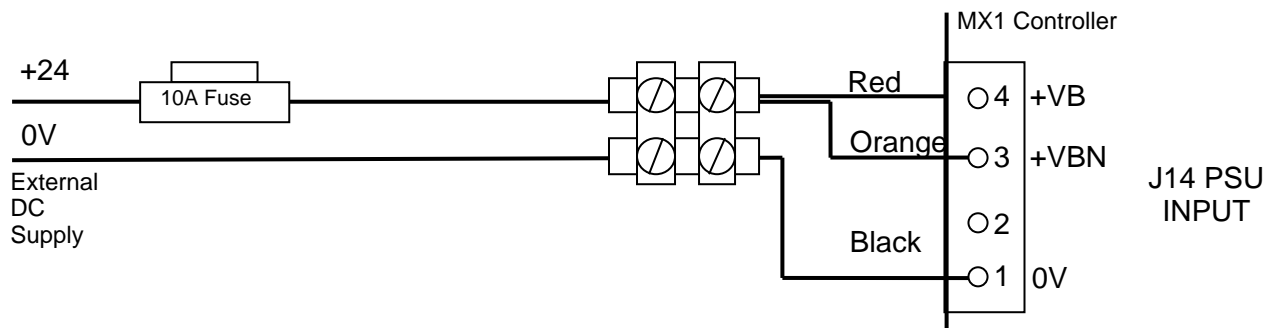

Figure 9.2 – External DC Power Supply Wiring

As no battery will be connected to the MX1, fit a mini-jump to the BATT CONN link LK3 to prevent the MX1 generating battery faults.

Because the panel will not be earthed via the mains power lead, a separate earth wire should be connected between the panel's gear plate and a suitable earth point. If the external supply is earthed, or is supplying another load that is earthed, then the Earth Fault monitoring must be turned off in the MX1 (using SmartConfig set point 241.25.3 to **Log Nothing** and **Hidden**).

The minimum operating voltage for the MX1 is 22V. The panel will generate the Power Supply Supervisory fault if its supply voltage drops below 21.8V. The Power/Operating LED will flash and a Mains fault will be generated if the supply voltage drops further (around 20V).

The cabling between the external power source and the MX1 must be rated to carry the maximum MX1 current and not allow the voltage to drop below 22V at the MX1 (a higher minimum voltage is recommended).

Using SmartConfig, set the following MX1 Controller sub-points to Log Nothing and Hidden.

<u>Point</u>	<u>Description</u>	<u>Logging Profile</u>	<u>Point Flag Profile</u>
241.25.1	Battery Low	Log Nothing	Hidden
241.25.2	Battery Connection	Log Nothing	Hidden
241.25.4	Battery Test	Log Nothing	Hidden
241.25.9	Battery Capacity	Log Nothing	Hidden
241.25.11	Charger High	Log Nothing	Hidden
241.25.12	Charger Low	Log Nothing	Hidden
241.25.13	Battery Fail	Log Nothing	Hidden

10 Zone Display Design

10.1 General

The *MX1*'s LCD can be used to view the states of any zone. Some aspects of the operation of the display, particularly the alarms list, are configurable on a per-site basis.

However, it is sometimes useful to have individual zone indicators to provide "at-a-glance" status information without requiring access to the *MX1* keyboard, especially for Fire Fighter use.

MX1 also has several options for driving remote zone displays which are located at another part of the protected premises. These remote displays can be compact LCDs, or individual zone indicators or a combination of these. Some of these remote displays can also provide limited remote control of the *MX1* system.

Additionally a Remote FBP can be connected to the *MX1* to provide a 2nd user interface for the brigade or site personnel use.

Networking of the *MX1* permits other types of remote displays to be used.

10.2 Zone LED Display Modules

10.2.1 Module Options

The *MX1* zone LED displays are driven from a connector on the LCD/Keyboard. This can display up to 192 zones and is compatible with the following zone display modules:

Compact Version (available as FP1002 extender kit)

The 8U and 15U cabinets have space for two x 16 zone LED displays (FP1002) on the keyboard door. The 15U cabinet can also be fitted with two 4U doors (ME0457) which can each hold five of these zone display modules, giving a total of 192 LED sets. One LM0092 cable will be needed to run from the LCD/keyboard to the highest number zone LED board on the ME0457, and 1 x LM0056 will be needed to connect LED displays on one ME0457 to either the next or to the *MX1* 4U inner door. An additional LM0056 will be needed when the second ME0457 is fitted. Drawing 1982-88 shows example arrangements.

Each module has 16 sets of indicators: one red LED and one yellow LED for each set. The red LED indicates alarm conditions, while the yellow LED is used to indicate fault conditions (flashing) or disable conditions (steady).

MX4428 Version (available as FP0475 extender kit)

The FP0475 is the older and larger 16 zone LED display also used in MX4428 and F3200. This module and the compact module are electrically compatible and can be arbitrarily mixed together in a installation. The 15U cabinet can be fitted with up to four of these modules on a 7U door (ME0060).

This module has 16 sets of indicators: one red LED and two yellow LEDs for each set. The red LED is for alarm, one yellow LED is for fault and the other for disable. Refer to the Configuration section below for more about using this zone display.

10.2.2 Distance Limitations

The port on the LCD/Keyboard used to drive the zone display modules is not protected, and should only be used to drive zone displays located in the *MX1* cabinet. If a customised zone display is required for an installation, mounting the zone display modules in another metal cabinet adjacent to the *MX1* cabinet would normally be acceptable.

10.2.3 Display Module Power Bussing

The *MX1* zone display module draws much less current than the older MX4428 display modules. This means that additional power wiring (“power bussing”) is not required for systems with up to 12 zone display modules.

For the MX4428 display modules, normal practice would recommend power bussing for systems with more than four modules. Since the 15U *MX1* cannot contain more than four of these modules, this means that power bussing is not required in standard *MX1* cabinets.

10.2.4 Configuration

MX1 Compact Version ZONE LED Module (FP1002)

This does not require any hardware configuration.

MX4428 Version ZONE LED Module (FP0475)

These displays must have Lk1 NOT fitted, unless one is used in the last (zone 1) position at the end of the display chain, in which case, Lk1 must be fitted to this one.

10.2.5 SmartConfig Configuration

In SmartConfig, defining a new zone will automatically assign a zone indicator position based on the zone number, e.g., zone 1 will be assigned to LED 1, zone 5 to set 5, etc. This indicator allocation can be overwritten: setting it to 0 will result in no zone indicator being assigned to this zone, while changing the number of the indicator will move the position on the zone display.

SmartConfig checks the LED mappings and will produce a warning if more than one zone is mapped to any LED. If the larger MX4428 displays are used, the *MX1* configuration will normally drive only the Alarm and Disable LEDs, flashing the Disable LED to indicate a fault.

If faults are required to be displayed on the fault LED, this can be enabled for a whole module by including the display board number in the list of “Non-*MX1*” LED boards in the System window of SmartConfig. Board number 1 is the one at the end of the chain, i.e., furthest from the LCD/Keyboard, with the lowest numbered LEDs.

10.2.6 Direct LED Control by Logic

The mapping of a zone to an LED results in the correct driving of the red and yellow LEDs by the zone’s Alarm, Fault and Disable states.

However, it is possible to individually control the state of each LED from user logic equations, if individual control is necessary for special display applications.

For example, an MX4428 zone display might be used to drive a 16 way relay board for additional relay outputs.

Refer to the section on *MX1* User Output Logic in the SmartConfig User Manual for a description of controlling LEDs via logic.

10.2.7 Zone Indicator Labelling

Front Panel Labelling

Individual zone indicators must be labelled with the zone name or designation. In the standard *MX1* keyboard overlay, this is done by means of a slide-in label, accessible from behind the module.

There are three recommended ways of creating these slide-in labels:

- SmartConfig can print labels directly from the information in the database. Zone names are used to label the LEDs controlled by the zone. For LEDs controlled by logic equations, the label will be the optional text assigned as part of the logic equation itself.
- LB0600 is a label preprinted on grey card which is a reasonable match to the colour of the keyboard overlay. There is no text on this label, which means that it can be used to blank over a zone display module position that is not used. Each MX1 is supplied with two LB0600. Text could be written/printed on this card if required.
- LT0369 is a Word document available from Johnson Controls. This is a form for five sets of labels. The zone names are entered into the appropriate parts of the form, and the completed form is printed at full-size onto appropriate heavy paper or light card. A suitable stock is Kaskad Owl Grey 225gsm card, available from commercial stationery suppliers. The printed form is then cut up and fitted into the pockets of the display overlay.

10.2.8 Common Alarm Type Indications

To enable common alarm type indications, for example, LEDs that show each of any smoke alarm, any heat alarm or any MCP alarm, a concept of alarm signalling types is included.

Each point that generates an alarm is assigned a default alarm signalling type as noted below.

Devices:	Alarm Signalling Type:				
	SMOKE (ALS)	HEAT (ALH)	MCP (ALMCP)	CO (ALCO)	OTHER (ALOT)
801F					X
814PH	X	X			
814H		X			
814P	X				
814CH		X		X	
814I	X				
850H		X			
850P	X				
850PH	X	X			
850PC	X	X		X	
DDM800					X
DIM800					X
MIM800					X
MIM801			X		
CIM800					X
QIO850					X
QMO850					
QRM850					
SIO800					X
MIO800					X
SNM800					
RIM800					
LPS800					
VLC800	X				
CP820/830			X		
MCP820/830			X		
801PHEx	X	X			
801CHEx		X		X	
801HEx		X			
CP840Ex			X		
IF800Ex					X
S271f+/S271i+					X
FV411f/FV412f/FV413f					X
SAB801					

SAM800					
Pseudo Points					X
Controller Inputs					X
RDU MCP					X
Keypad Points					X

When a point enters alarm, the zone(s) the point is mapped to also enter the alarm condition. As well as maintaining a common alarm state the zones also track the Alarm Signalling Type(s) of its points in alarm. For example, Z1ALMCP will become true when one or more points with an MCP alarm signalling type that map to zone 1 go into alarm.

These extra Alarm Signalling Types are available on a per-zone basis in output logic, using the corresponding ALxx zone token as indicated in the above table. The ALxx states are forced FALSE if the zone is disabled, just as is the zone's usual alarm state.

Zone Groups to which the zones are mapped also track the ALxx states for the zones mapped to them and provide corresponding ZGnnnALxx states themselves to the output logic.

The different alarm signalling type tokens can then be used in logic equations to drive alarm LEDs on the MX1 LED boards and alarm LEDs sent to RDUs to provide the common alarm signalling type indications.

10.2.9 Changing the Alarm Signalling Type

In some cases it may be desirable to have a device indicate a different alarm type than its default. For example, a MIM800 with a heat probe should signal heat alarm.

Within SmartConfig, an input's alarm type is set by default as per the table in 10.2.8. This can be changed for MX devices by selecting a different option using the drop down selector in the Alarm Type field.

Thus a MIM800 monitoring a clean contact heat probe can be changed from "Other" to "Heat".

10.3 Alphanumeric Alarm Display

10.3.1 Zone information on the LCD

The LCD in the MX1 is available for display of zone information in a number of ways:

- Alarm Display - The display shows critical alarm information for use by firefighters. Many aspects of the operation are adjustable in the site specific configuration to change how information is displayed, which controls are active, and how much information is shown. These are described in the SmartConfig User Manual.
- Zone Status Recall - the MX1 keypad may be used to recall status of zones and perform commands on zones. Access to recalls and controls are controlled by operator Access Levels, as described in the MX1-Au Operator Manual (LT0439), along with the available recalls and commands. Control of Access Level 3 requires a username and password, configuration of which is described in the SmartConfig User Manual.

10.3.2 Alarm Display Design

There are a number of site specific configuration settings that control the display of alarms on the LCD. These settings are made within SmartConfig via the System profile selected and the properties assigned to that profile.

To meet statutory requirements, the correct settings should be used. Other settings may be chosen to suit the requirements of the project.

Refer to the SmartConfig User Manual for details.

10.4 Using RZDU Port

MX1 has a facility to transmit zone status information via its RZDU port to zone displays which may be located some distance away. Some examples of remote zone displays that can be used with the *MX1* RZDU port include:

- Remote Display Unit (RDU) – provides an alphanumeric display with optional individual zone indicators.
- Nurse Station Annunciator (NSA) – provides an alphanumeric display and a 3 position keyboard, for special applications such as annunciation of alarms at a nurse station.
- IO-NET Mimics – a lower cost option to RDU, but which has only individual zone indicators.

The *MX1* supports only the LCD-A RZDU protocol so the receiving device may need to be programmed for this. Also the *MX1* sends only the Point Text in zone FF alarm messages so it may be necessary to program the Point Text with sufficient detail to clearly identify the alarm location.

Note: The RZDU protocol supports the transfer of up to 528 zones of information. The *MX1* supports 999 zones, but only the first 528 of these can have status sent through the RZDU port.

10.5 RDU/NSA

10.5.1 General

The RDU is an intelligent Remote Display Unit that can connect to an *MX1* system to remotely indicate zone status and optionally control the *MX1*. It must not be provided for fire brigade use – use the Remote FBP instead.

The NSA is a much smaller unit, has just 3 keys on its keyboard, and is usually used for special applications like nurse stations, etc.

Up to 8 RDU/NSAs can be multi-drop connected to an *MX1* to achieve a distributed control and indication capability. Additional RDU/NSAs can be connected if they are display only (no control).

The RDU is available in several formats, with or without a PSU – refer to the RDU product information. The NSA is available in wall mount and flush mount cabinets, and is usually powered by the *MX1*.

The RDU and the NSA have a high degree of flexibility. Each can be programmed as to which of zones 1 to 528 that it will process. This means that, in multiple RDU/NSA systems, each RDU/NSA could be assigned the zones corresponding to its own particular area. Alternatively, all RDU/NSAs could be configured for all zones if required. An RDU (not an NSA) can be programmed to simply mimic the *MX1* zone status, or it can be programmed for control as well, thus allowing the operator to reset or disable zones from the RDU.

10.5.2 Connection

RDU/NSAs are connected to the RZDU port on the *MX1* Controller. This is a four terminal port: +VRZDU, 0V, TX, and RX. The 0V, TX and RX terminals must be connected to the RDU/NSAs, but the VRZDU connection is required only if the RDU/NSA is being powered from the *MX1*. If the RDU has its own power supply, it must not be connected to the VRZDU terminal on the *MX1*.

Wiring between the *MX1* and RDU/NSAs can be daisy chain or star or a combination of these. There are no special requirements of the type of cable used for RDU/NSA connections. A single four core or a pair of twin core cables can be used equally well.

If there are line powered RDUs with zone displays connected, the 0V and +VRZDU conductors must be sufficiently large to avoid excessive voltage drop under load. Refer to the RDU Installation and Programming Manual for detail about supply requirements for the RDU.

Figure 10.1a shows the general wiring of the *MX1* to RDU/NSAs or other similar products when there is no T-Gen2 HLI Module present. Note that a single short circuit on the Tx line from the *MX1* could stop data being sent to all devices. If short circuit isolation is required – e.g., when a QE20 or QE90 is also connected to the RZDU bus, a short circuit isolated output must be provided as shown in Figure 10.1b.

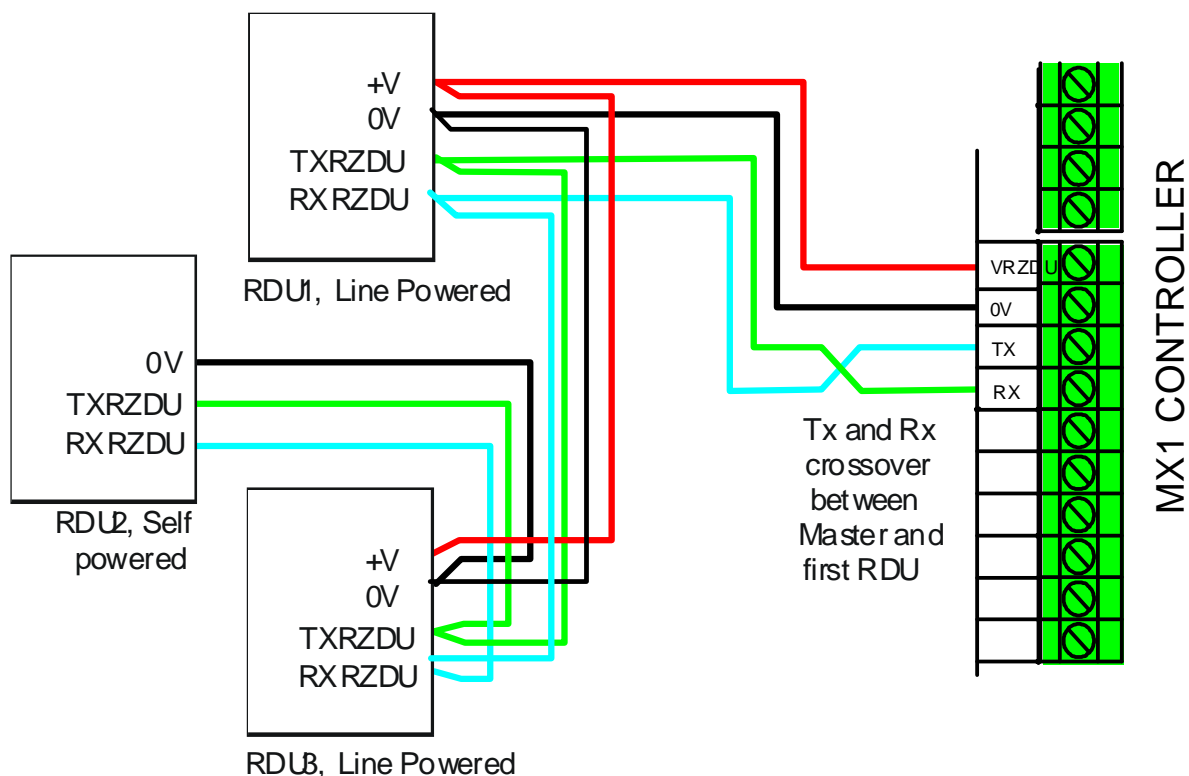

Figure 10.1a – General Wiring between *MX1* and RDU/NSAs

Figure 10-1b shows the wiring when a T-Gen2 HLI module is included. The links LK1 – 4 on the HLI Module need to be set to the RZDU position.

Note that the MX1 RZDU port is wired to the HLI module FIP connector J3, with Rx and Tx crossed over. All field RZDU devices are wired to the RZDU field terminals (J4) on the HLI module with a cross-over of Tx and Rx to the first device. The connection to a co-located QE20 or QE90 panel is made off the internal RZDU terminals. The connection to the T-Gen2 is made using an FRC cable from J2 on the HLI Board.

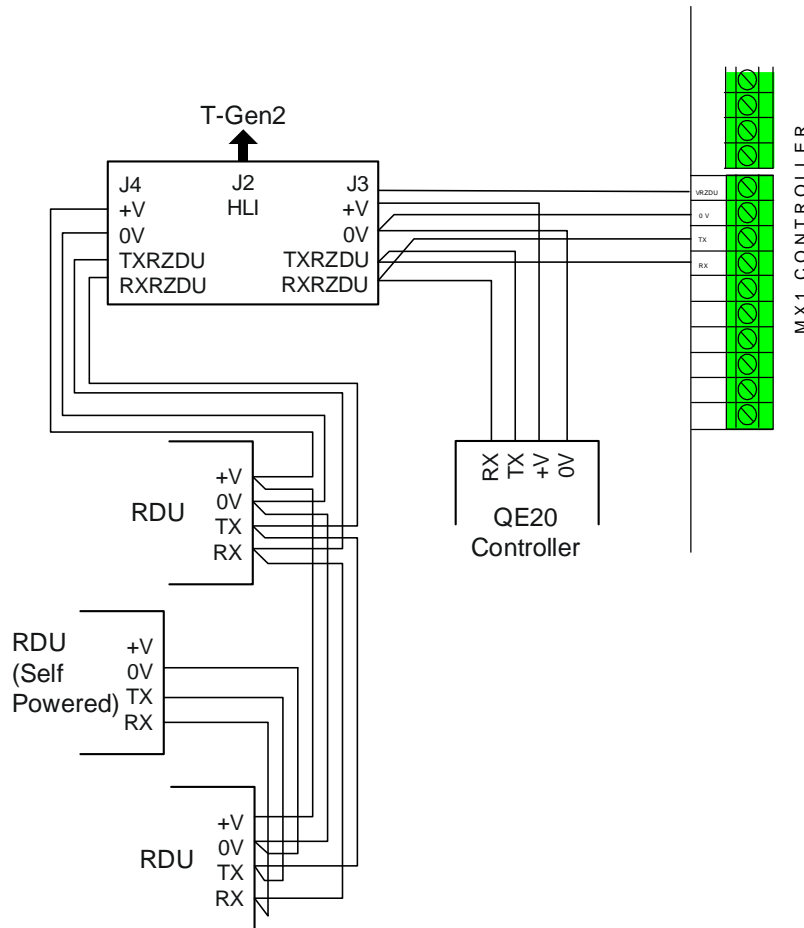

Figure 10.1b – RZDU Wiring with T-Gen2 HLI Module

10.5.3 Configuration

The RDU/NSA is configured separately from the *MX1*. Currently, SmartConfig cannot be used for configuring an RDU or NSA, except that the “RZDU LED number” for each zone, as transmitted to the RZDU port, can be configured in the *MX1* Zones window of SmartConfig.

Refer to the RDU Installation and Programming Manual (LT0499) for detail about the configuration of the RDU, and to the F3200/NDU/ADU AS4428.1 Programming Manual (LT0256) Section 6 for programming the NSA.

In *MX1* zones can be separately mapped to LED sets (shown on the *MX1*) and to RZDU LEDs (sent via RZDU bus). E.g., *MX1* zone x can map to RZDU zone y, or to no RZDU zone at all. However, for zone alarms to display on the RDU/NSA LCD and clear as required, the RZDU LED number and the *MX1* zone number must be the same.

The RZDU LED number is the number used by the *MX1* to transmit the zone status via the RZDU port. All devices connected to the RZDU port will see the same set of RZDU zones. It is not possible to have different zone mappings for different RZDU devices. Thus different

MX1 zone to LED set and zone to RZDU zone mappings could be used. Alternatively, logic equations can be used to control the RZDU zones directly.

In general, there would be little advantage in using different MX1 and RZDU zone numbers except to manage the order of zone indicators on a mimic display.

10.5.4 Short Circuit Isolated Tx Output

Figure 10.2 shows how PA0481 RZDU/RS232 Interface Boards can be used to provide short circuit isolated Tx outputs from the MX1 panel. Separately fused +VRZDU outputs may also be needed to provide isolation in case of shorts on the +VRZDU wires. Insert fuses at positions *1 of Figure 10.2, or use separately fused outputs off MX1. Note this arrangement does not solve a short on the Rx line back from the remote RDUs.

On each PA0481 set the links as follows:

Lk1 = RZDU, Lk2 = RZDU, Lk3 = FIP, Lk4 = FIP, Lk5 = FIP

Connect the TXD and RXD terminals together on J2. Connect the + and – J2 terminals on the PA0481 to the +VRZDU and 0V signals to provide power to the PA0481 board.

An alternative is to use the FP1143 HLI interface board to provide a short-circuit isolated RZDU output. Refer to drawing 1982-71 Sheet 139 in LT0442 for details.

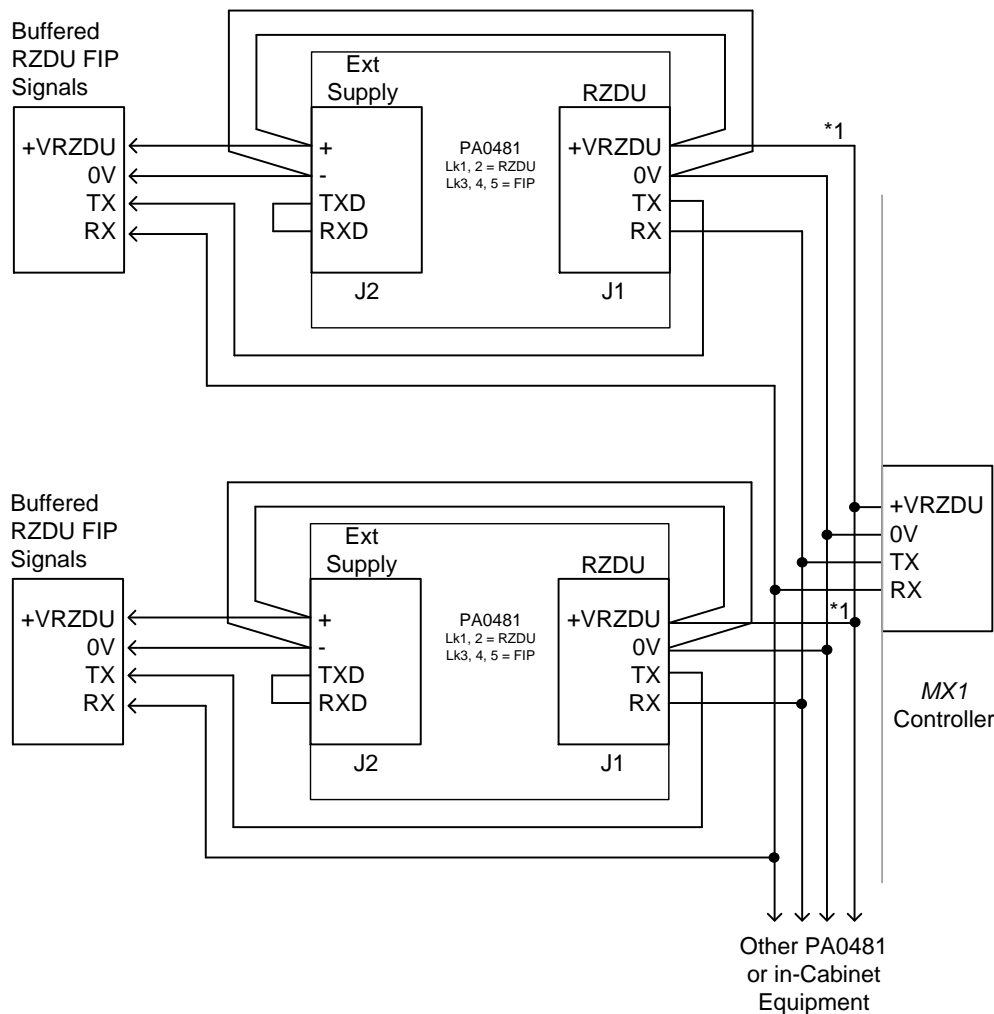

Figure 10.2 – Short Circuit Isolated RZDU Outputs

10.6 IO-NET Mimic Displays

If a simple remote zone display is required for an *MX1* installation, an IO-NET Controller may be a cost effective means of achieving this. The IO-NET Controller can be connected to the RZDU port of the *MX1*, and can be configured to use the received zone status information to control up to 32 zones of indication. If more than 32 zones are required, multiple IO-NET Controllers can be used, each additional IO-NET increasing display capacity by 32 zones.

This method does not support control inputs being passed back to the *MX1*.

10.6.1 Ordering Details for IO-NET

Ordering Code	Quantity
PA0481 PCB ASSY,1901-100,F4000 RZDU/RS232 I/F,C/W LOOM	1
PA0498 PCB ASSY,1901-117,IO-NET CONTROLLER	As required by number of zones
PA0475 PCB ASSY,1901-73-2,F4000 IOR 32 OUTPUT TERM BD	1 per PA0498
LM0291 LOOM,FRC,26W,STYLE B,270mm or LM0046 LOOM,FRC,26W,STYLE B,500mm (depending on physical mounting arrangements)	2 per PA0498

This list does not include actual LED indicators or mounting hardware or cabinetry or miscellaneous wiring, since these will be installation dependent.

10.6.2 IO-NET Wiring

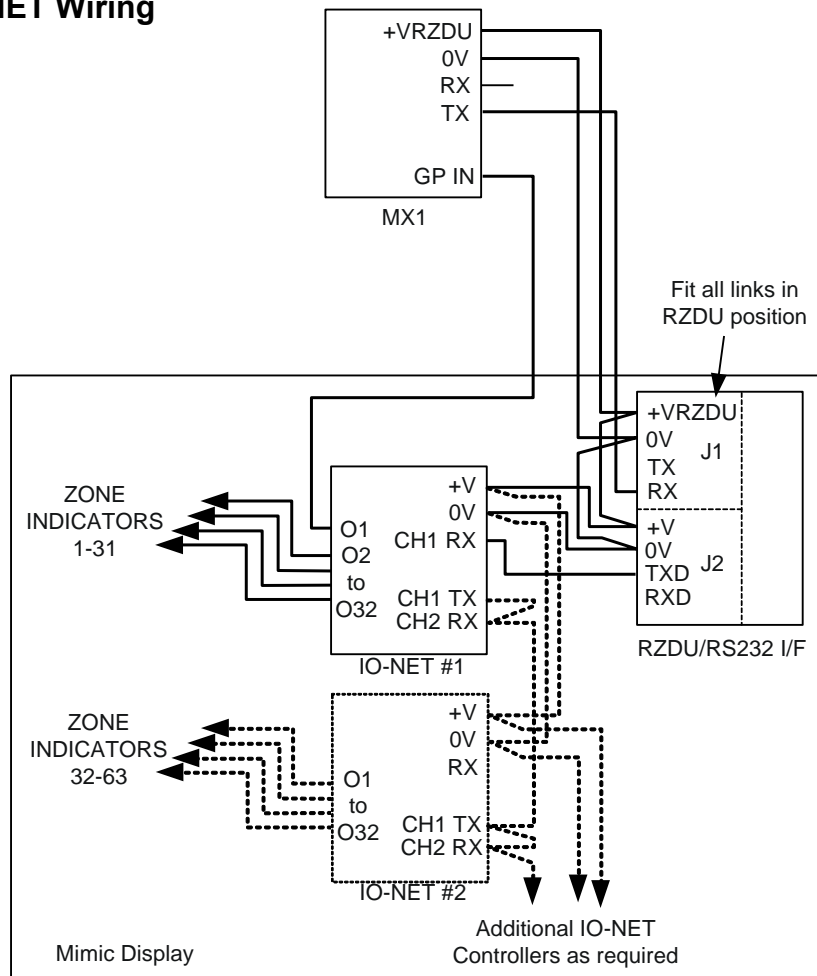

Figure 10.3 – General Form of a Mimic Display using IO-NET

The mimic display can be powered from the MX1. In this case, the 0V and +VRZDU conductors must be sufficiently large to avoid excessive voltage drop under load, especially under lamp test conditions. The voltage drop in the 0V conductor between the remote mimic and the MX1 must not exceed 2V under maximum current conditions, otherwise any supervision signal to the MX1 will be degraded and a fault will be generated.

If fault supervision of the LED displays is required, one of the spare outputs of an IO-NET Controller can be fed back to a General Purpose Input on the MX1 Controller, to allow display faults to be indicated. This output should be programmed in the IO-NET Controller to be pulsing regularly when the mimic display is operating, ceasing to pulse if there is a power or communications failure to the mimic display.

For battery calculations, the current drawn by each IO-NET Controller must be allowed in Non-Alarm load and Alarm Load figures. The Alarm Load should also include an allowance for the current of 4-5 indicators, which are the zone indicators which have operated during the alarm.

10.6.3 Configuration

MX1

The MX1 does not require any special configuration to transmit zone information to the RZDU Mimic Display port, other than to set the “Maximum Zones of Information” field in the System Window of SmartConfig.

If a General Purpose input is used for fault supervision it should be configured as follows.

Profile Name		Band 1 Condition		Band 2 Condition		Band 3 Condition		Band 4 Condition	
G. P. Input 1	...	Active	...	Active	...	Active	...	Fault	

The logic equation controlling the status of the pseudo point representing the mimic display should be:

```
Viii = P241/2/0AI ; true when GP Input 1 is pulled low
TSjjj(0,10)FO = ViiiE
PPppp/0FA = NOT Tjjj
```

i.e., the pseudo point will go into the Fault condition when the GP Input is not pulsed for more than ten seconds. The pseudo point should have a Point Flags Profile which maps it to the fault routing.

IO-NET

For details of wiring and configuring the IO-NET Controller(s), and for wiring of LEDs to the Output Termination boards, see the IO-NET User Manual (LT0115).

Each IO-NET must be programmed with a set of logic equations to control the LED outputs from the received MX1 zone information. Each IO-NET has a slightly different program.

The logic for the first IO-NET Controller could be:

```
; map RZDU zone 1 to output2, zone 2 to output3, etc
O2 = Z1:1A
...
O32 = Z1:31
```

If an output (e.g., 1) is required to signal a mimic fault to the *MX1* it could use the following logic.

```
; Check Panel communications and output connections  
; and pulse output x active (low) when all is OK  
T1(0,32) = PR1  
;create pulse for supervision output  
T2 (2,2) = NOT T2  
O1 = T1 AND T2 AND OB1 AND OB2
```

If there is more than one IO-NET Controller, change the T1 line in the above program to include each additional controller:

```
T1(0,32) = PR1 AND IR2
```

If it is necessary to use a more complex mapping of zones to LEDs, there are two ways of doing this:

1. Change the IO-Net program equations so that the zone information maps to different LEDs on the mimic. This method is less convenient for making changes, but does not affect any RDUs or other devices that may also be connected to the *MX1*'s RZDU output.
2. Use the *MX1* facility to change the mapping between *MX1* zone numbers and RZDU LED numbers, in the Zones table of SmartConfig. Note that this new mapping affects all devices connected to the *MX1*'s RZDU output. It may lead to inconsistent or confusing displays on RDUs.

The recommended method is to keep the default mapping of *MX1* zones to RZDU LEDs as in method 1 above, since this has much less scope for confusion and problems.

10.7 Remote FBP

One Remote Fire Brigade Panel (FBP) can be connected to the *MX1* to provide a second user interface for fire brigade or site personnel use.

The Remote FBP works independently of the *MX1* user interface, but uses the same core data, e.g., zone states, alarms, buzzer on/off, and muting. For example, users can be doing different things on the two user interfaces at the same time, but operate off the same data. For example, silencing the buzzer on one unit will silence the buzzer at the other as well.

In SmartConfig the Remote FBP must be enabled and configured for the serial port (0-4) that it is connected to. Note using Serial Port 0 will disable the RZDU port.

On the System Page there is a choice for “**Disable FBP when panel is in Alarm**”. When this is ticked the Remote FBP keyboard will be disabled when there is an alarm present, to stop the Remote FBP user interfering with the fire alarm. This is used when the Remote FBP is not for fire brigade personnel. This should be unticked (**default**) when the Remote FBP is to be used by fire brigade personnel.

Also note points 246.37.0, 246.37.1, and 246.37.2 do not work independently of the *MX1* front panel, but follow the 243.37.x points.

To connect a Remote FBP a PA0773 RS485 board must be installed in the *MX1* panel and connected to the Serial Port allocated in the site configuration for the Remote FBP. +24V power must also be provided to the RS485 board and to the Remote FBP. These parts and full installation instructions are included with the Remote FBP (LT0532).

Drawing 1982-71 Sheet 130 shows the wiring in the *MX1* and to the Remote FBP.

10.8 Networked Remote Displays

With the addition of networking equipment (refer Section 14) the *MX1* is able to use other units for remote displays. For example:

- A complete *MX1* panel on the network with no addressable loops and devices could be used as a remote display (and control unit). This can be programmed to display a selection of alarms (by panel) and what faults and other conditions it should show.
- Nurse Station Annunciator (NSA). The NSA supports Panel-Link networking in either point-to-point or multi-drop modes. So each NSA could be connected directly onto an *MX1* network using its own I-HUB or PIB (etc.,) together with a suitable power supply.

If the NSA is configured for multi-drop mode, multiple NSAs could be put onto a dual channel RS485 bus and connected via a suitably configured port on an I-HUB and onto the *MX1* I-HUB or PIB ring.

- The NSA can be programmed as to which zones it displays – allowing a finer grain selection of zones from the network rather than all zones for selected panels.
- Network Display Unit (NDU). The NDU supports Panel-Link networking in either point-to-point or multi-drop modes.
- Compact FF. The Compact FF is electrically the same as an NSA but it has additional keys and LEDs.

THIS PAGE INTENTIONALLY LEFT BLANK

11 Alarm Routing/Brigade Signalling

11.1 Alarm Routing/Brigade Signalling Options

The *MX1* Controller has three interfaces for use with different alarm routing/brigade signalling equipment. Two of these are specific to particular types of brigade signalling equipment, but the third is more general.

- ASE Interface (J12) – is a 2 wire connector designed for direct connection to a Centaur ASE.
- Brigade Relays (J9, J10, J11) – Alarm, Fault and Disable voltage-free changeover contact outputs for wiring to most other signalling systems.
- Brigade Signalling Interface (J8) – is a 10 way FRC header with unisolated, unprotected open collector outputs and inputs. It supports Signal Generating Devices (SGDs), however none are currently in use in Australia.

The functioning of the alarm routing outputs is determined by the database output logic and relevant controller point settings, which may themselves be determined by settings within System Profiles.

11.2 Centaur ASE

The ASE interface (J12) on the *MX1* Controller can be directly connected to a FAS input of a Centaur ASE. There is no need for an FP0740 ASE FAS Interface Board – Figure 11.1 shows the wiring.

This 2 wire port is protected and isolated, which makes it equally suitable for wiring to an ASE mounted in or close to the *MX1* cabinet, or to an ASE located remotely in the premises.

It provides alarm, fault, and disable (isolate) signals using a normally-closed configuration, as used on Centaur ASE inputs. Note the earlier PA1011 Controller has normally open contacts – which doesn't match the usual ASE programming.

In addition a Power Supply Fail signal will usually be required. Refer to Section 9.1.4 for how to provide this. The Normally Closed contacts of the relay need to be wired to the ASE PF input and 0V, so that when the relay de-energises the contacts short the ASE PF input to 0V.

For fitting into the *MX1* 15U cabinet, an ASE can be mounted on a 3U ASE mounting plate KT0199.

If the Centaur ASE is mounted in the *MX1* Cabinet, it can be powered from the +VBF terminals of the Controller.

If at all possible, use one +VBF terminal solely for powering the ASE, to avoid other load wiring faults from blowing the fuse and depowering the ASE.

For 8U *MX1* panels the Centaur ASE will need to be mounted externally.

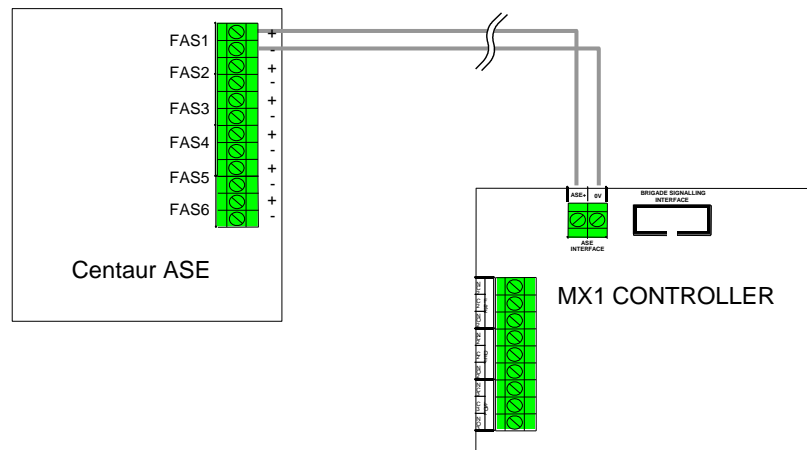

Figure 11.1 – ASE Input Wiring Details

11.3 Brigade Relays

The *MX1* provides 3 sets of change-over contacts for the Alarm, Fault and Disable relays on J9, J10 and J4. The Alarm and Disable relays are normally de-energised, while the Fault relay is normally energised – dropping out when operated or when power drops below the minimum operating voltage or a hardware fault occurs on the Controller. The contacts can be wired to external signalling systems.

Note that the second pole of each relay is used in the Centaur ASE Interface.

These relays be used for other purposes if they and the ASE interface on J12 are not required for alarm routing.

Set the existing equation for `$FREE_USE_BRIGADE_RELAYS` to be TRUE and then modify the existing equation for `$FREE_USE_ALARM_RELAY`, etc, to what is required.

Refer Section 8.7 for an example of using a brigade relay.

11.4 Power Supply Fail Output

Most alarm signalling options require a separate output that signals when the *MX1*'s power supply is below the minimum operating voltage. Refer to Section 9.1.4 for providing this.

11.5 WEST AUSTRALIA ASE

The FP0928 *MX1* panel is supplied with a 3U door with a mounting position for the LCD module of the WA ASE unit. Also included on the door is the screw terminal strip for wiring between the panel and the ASE. The master unit of the ASE will generally need to be mounted inside the cabinet somehow.

Refer to the instructions supplied or drawing 1982-71 sheet 145 for the wiring diagram.

11.6 SOUTH AUSTRALIA

In South Australia the SAMFS require a specific type of operation on the *MX1* FBP for alarm disabling. Pressing the Disable key needs to disable the points (e.g., detectors) in alarm, rather than the zones in alarm. This is available in *MX1* firmware V1.51 and SmartConfig 2.4.2 (and onwards) with the V1.50B (and onwards) template.

Select the **AU SA** system profile on the System page.

This has the **FBP 2010 Operation** setting enabled, which changes the FBP Disable function to disable the points in alarm.

Most zones should use the “**Std Detection G1 Multi-Alarm**” zone profile, which allows a zone to have each of its points in alarm shown in the alarm list.

11.7 NORTHERN TERRITORY

In NT the fire brigade uses the NTFAST system, which requires the purchase and fitting of a Miri Telemetry Unit and NTFAST LED/Switch PCB to the fire panel.

To facilitate this in *MX1* panels a pre-wired 6U door is available – part number FP1092. The Miri Telemetry Unit and LED/Switch PCB are fitted and wired on to the door according to the instructions in LT0623.

The *MX1* panel requires 5 additional relay outputs (above the standard Alarm, Fault and Disable Brigade I/F relays), which are typically provided by fitting a 16 way Relay Board (PA0470) connected to the 16 open collector outputs of the LCD/keyboard.

If the 6U door is mounted 0-2U below the LCD/keyboard there is no clash with the internal parts. If the 6U door is mounted 3-5U below then the battery space is limited to 17Ah, so an external battery box may be required.

The NTFAST brigade kit consumes 125mA in the quiescent and alarm states, so this needs to be included in the PSU and standby battery calculations.

12 Remote Access

12.1 Remote Access

12.1.1 General

The *MX1* has a number of serial ports that can be used to communicate with external devices. This chapter details how to remotely connect to an *MX1* for the purposes of configuration, diagnostics, front panel access and also for the paging of alarms and other system events.

Nearly all front panel operator functions and many service functions can be carried out via a PC connected to the Diag/Prog serial port on the *MX1* Controller.

This connection could be:

- A direct serial cable from the PC – this would be a normal means during system installation and commissioning. This will give the highest speed connection, with the fastest download times for data files or firmware.
- A remote connection via a dial-up modem, set up for answer-only operation. The connection speed will generally be less than for a direct serial connection, but will be acceptable for most purposes. There are several choices of modem: V-Modem (now obsolete), commercial off-the-shelf PSTN modem, cellular radio modem.
- A remote connection via a terminal adaptor (serial to Ethernet) or PIB connected to a LAN or WAN. Depending on the nature of the LAN or WAN, this should provide a high speed connection.

Using the PC connected to the *MX1* in this way, you can:

- Use the PanelX software to provide a “virtual” front panel on the PC display. This simulates the LCD and keys of the *MX1*, but not the individual zone indicators.
- Use a terminal emulator program, e.g., SmartConfig, Hyperterminal or WinComms, to access the diagnostic commands for detailed fault finding or service.

Note: Where the *MX1* is to be remotely accessed, precautions must be taken to ensure that the remote operation can be achieved safely, in compliance with the relevant Standards and codes, and with appropriate security to ensure system changes (e.g. isolation of zones or points, programming changes) are authorised.

For example, a keyswitch may be necessary at the panel to disconnect the remote access facility until authorised on-site by operating of the keyswitch.

12.1.2 V-Modem

V-Modem is a now obsolete standalone PSTN modem. It can be configured to operate in several modes, and does not require any supporting configuration in *MX1* for use with it. It can be powered from the *MX1* internal supply so as to not be affected by mains failure. It is designed for reliable long-term operation without requiring attention.

For remote access to *MX1*, the V-Modem installed at the *MX1* must be configured for “Dialup – Answer” operation. V-Modem will automatically answer calls, but will not originate calls. While it is off-line, any data received from the *MX1* will be discarded.

A V-Modem can be mounted in the *MX1* 15U cabinet by using an ASE Rack Mounting front panel kit, part number KT0199, or KT0212 2-Up Rack Mounting Kit which can mount a V-Modem and an ASE.

Wiring

Wire as shown in Fig 12.1. Power can be taken from any of the +VBF terminals, though it is best to use an unused terminal (often +VBF2). Include the V-Modem’s current in battery calculations.

The LM0166 cable from the V-Modem can be connected directly to the Diag/Prog serial port on the MX1 Controller. A “straight” serial cable with male and female DB9 connectors can be used to provide additional length between the LM0166 and the MX1 if required. Suitable cables are available from electronics or computer accessory suppliers.

The PA0730 relay board only needs to be included if site-specific datafile downloading over the V-Modem connection is required. The OC2 output of the V-Modem turns on whenever the V-Modem is on line, thereby write-enabling the database.

Configuration

Set the V-Modem to “Dial-up Answer” mode, 19200 baud, with Xon/Xoff enabled on all ports.

Note that although the MX1 to V-Modem serial link operates at 19200 baud, the remote PC needs to dial in and communicate at 2400 baud, which is the actual communications rate.

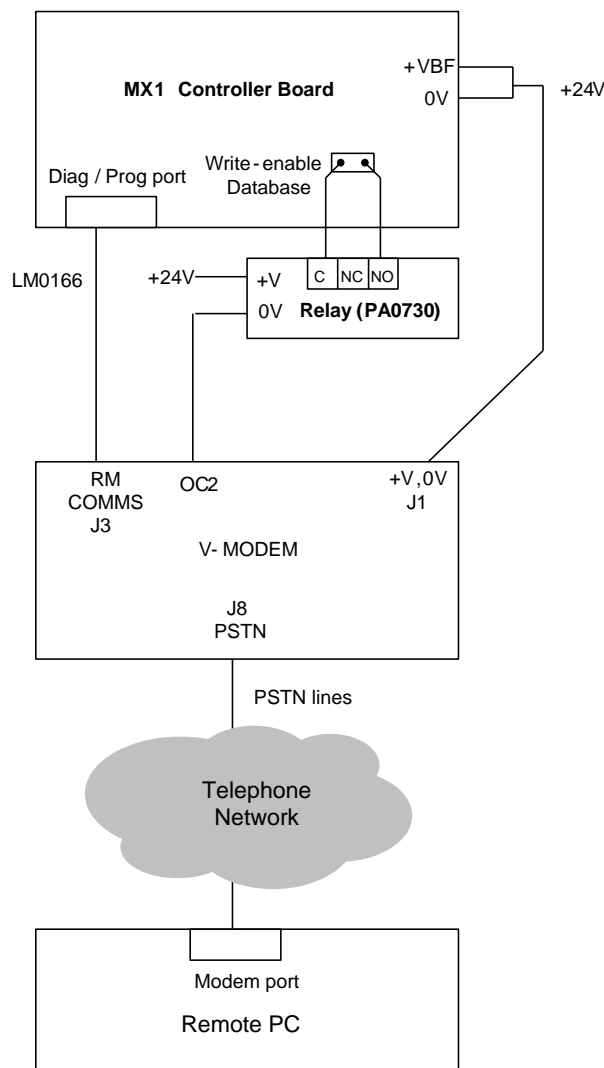

Fig 12.1 – V-Modem Connection

12.1.3 V-Modem Ordering Details

Ordering Code	Quantity
FP0778 V-Modem (fitted with LM0166 and includes a User Manual – LT0243)	Now Obsolete
A suitable PSTN lead is required.	1
“Straight” serial cable with male and female DB9 connectors, e.g., Vigilant part LM0138 LOOM,DB9M-DB9F, ALL PINS STRAIGHT THRU,1.8M.	If required to extend the serial connection.
KT0199 ASE 19” RACK MOUNTING FRONT PANEL KIT	1, if mounting in 15U cabinet.
PA0730 24V GEN PURPOSE 2A 2CO RELAY BD	1, if remote control of data file write access is required.

12.1.4 Commercial PSTN Modem

For short term use during installation and commissioning, a commercial PSTN modem can be used for remote access.

Long term use of such a modem for remote access to *MX1* is not recommended. In general, these modems are not designed for long term unattended use, and the internal program execution can “lock up” and require manual intervention to be restarted. Arranging for standby power during mains-fail is also more complicated, since these modems use a mains plug pack for power, and cannot be powered from the *MX1* internal supply. A separate power outlet will be required.

Mounting

For short term use, it may be possible to tuck the modem inside or on top of the *MX1* cabinet.

Wiring

Serial – the modem serial port can be connected directly to the Diag/Prog serial port on the *MX1* Controller, via a “straight” serial cable with male and female DB9 connectors. Suitable cables are available from electronics or computer accessory suppliers. The modem must be no more than a cable distance of 15m from the *MX1*.

Power – the modem plug pack must be connected to a mains outlet.

Configuration

The modem must be set up to answer incoming calls by itself, without any support from the *MX1*, and to automatically hang up when the call is ended. The response codes sent by the modem to the *MX1* must be suppressed. The modem must be capable of operating at 19200 bps data rate to the *MX1*. Any modern V.34 or V.90 PSTN modem should be capable of doing this.

This initialisation string (check the modem manual for details):

```
AT S0=2 S7=30 E0 Q1 &W
```

should set up the modem for:

- Automatic answer after two rings
- Automatic disconnection 30 seconds after the calling modem hangs up

- Disabling sending response codes
- Saving this configuration to non-volatile memory as power-on default.

12.1.5 PIB

The Panel-Link IP Bridge (PIB) can act as a IP to serial adaptor to allow connection to the *MX1*'s diagnostic (or printer) port over a LAN/WAN. It mounts on a "responder" footprint, so can be fitted on the right hand wing of a 15U gear plate, or instead of the T-Gen2 or T-GEN 50 on the 8U and 15U gearplates. It can be powered by the *MX1*.

PanelX, SmartConfig, Wincomms, Hyperterminal, etc., can be used on the PC on the LAN/WAN to "telnet" to the PIB's remote access port and into the *MX1*. Details are contained in the PIB User Manual (LT0519). Refer also to Section 14.

12.1.6 Terminal Adaptor

These are small modules designed to connect between the serial port of equipment and a local area network using Ethernet.

With appropriate software, a PC connected to the LAN can access the serial port on the equipment.

Different manufacturers use different names for these devices, e.g., Device Server, Universal Serial Device Gateway, or IP to Serial Adaptor.

Two devices that are known to work with *MX1* are:

- Lantronix UDS-10 – see www.lantronix.com. Requires DB9 female to DB25 male "straight" serial cable. Can be powered from the *MX1*'s d.c. supply or from a suitable mains adaptor.
- Advantech ADAM4577 – see www.advantech.com. Requires null-modem adaptor between its serial cable and the *MX1*. Can be powered from the *MX1*'s d.c. supply.

MX1 does not require any special configuration to work with these adaptors.

Refer to the manufacturer's documentation for configuration of the terminal adaptor. It must be capable of a data rate of 19200 bps, 8 bits/character, no parity, to the *MX1*, and for receiving TCP socket connections from the LAN. Connection of the terminal adaptor to the LAN must be done with the assistance of the LAN administrator so as not to adversely affect the network's operation.

Note that, generally, the terminal adaptor will need to be assigned a fixed or known IP address or host name so that users can connect to it.

12.1.7 PanelX

PanelX (SF0281) is a Windows-based program that can be used to access an MX1 via a simulated front panel display and control it remotely.

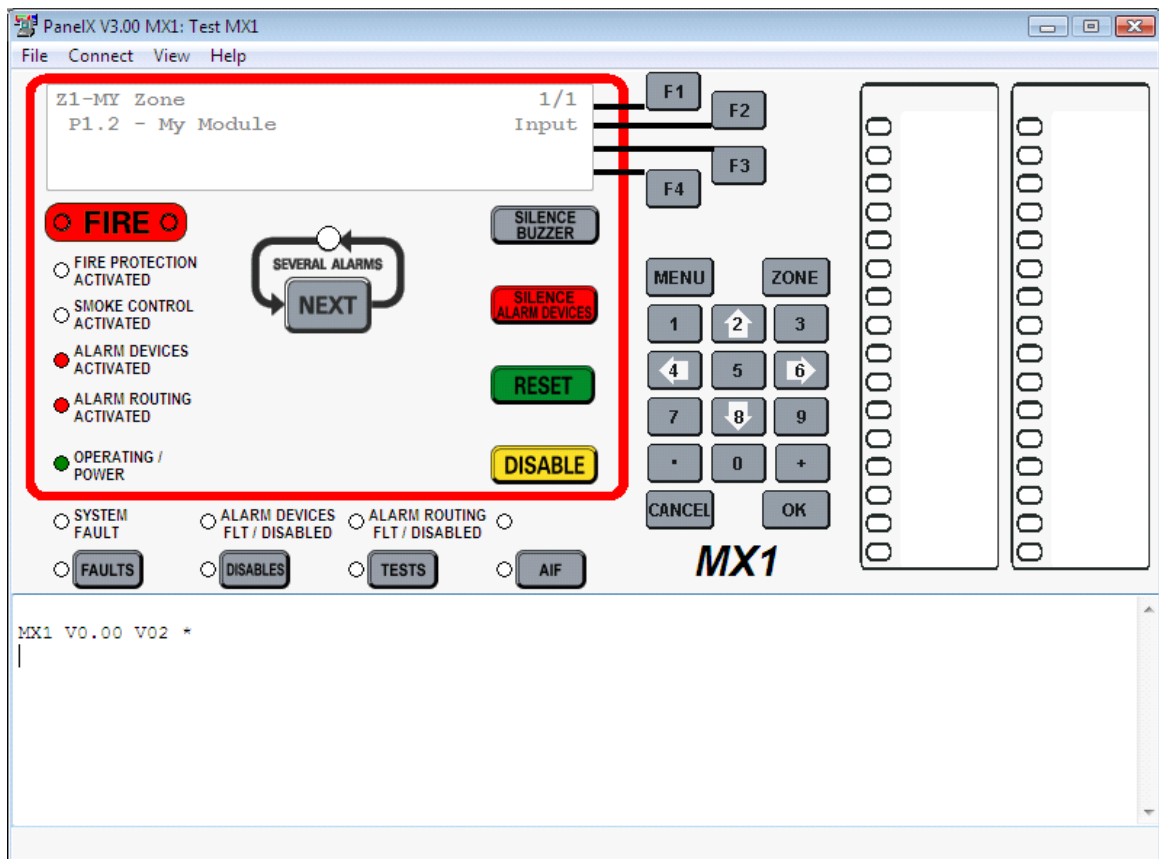

Figure 12.2 – Sample Screenshot of PanelX Display

PanelX supports direct RS232 connection, dialup connection using a modem, and a TCP/IP network connection, and uses Tandem Mode to access the panel.

Note: A 'Tandem Mode' connection to MX1 logs onto a separate virtual instance of front panel, not the actual front panel. Operation by remote connection will be invisible to a user at the physical front panel. Tandem mode and front panel access are independent as far as is possible when operating the same system.

PanelX is available as SF0281 PanelX Remote Communications Software. Version 3.00 or higher is required for use with MX1. To install the program run the SF0281 file and set up the connection details for the panels to use. Further information is contained in the Help file included with PanelX.

12.1.8 Telepager Interface

The VIGILANT Telepager Interface (TPI – now obsolete) can be connected to an MX1 printer port and be programmed to send messages to alphanumeric pagers or message-receiving cellular phones when certain events occur.

Refer to LT0206 for full details on the use of a TPI. Connect the MX1 Controller's Serial Port 1 (J23) to the TPI's RS232 Port B using cables LM0076 and LM0065.

Note that TPI V1.60 or higher software is required to support the MX1 with V1.50 onwards firmware.

12.1.9 Diag/Prog Port as Printer

With *MX1* firmware V1.51 and onwards it is possible to configure *MX1* to output the printer events using the Diag/Prog Serial port.

Printer output is shared with the diagnostics and programming functions. When the Diag/Prog port is not logged on, it operates as the printer output – displaying events as they occur. If the Enter key is pressed to start the logon sequence, the log on prompt is given and event printing stops – events are buffered internally until the diag/prog function is complete. If no valid user name/password is entered, or the user logs out of diag/prog mode, there is a short delay then event printing is re-enabled. Any buffered events are then printed.

This port operates at a fixed baud rate of 19200.

In SmartConfig 2.4.2 and onwards the outputting of printer events on the diag/prog port is enabled with the **Print Events to Diagnostic Port** setting on the System page.

THIS PAGE INTENTIONALLY LEFT BLANK

13 Upgrading Existing Systems

13.1 Upgrading Existing MX1 to Multi-Loop

13.1.1 Upgrading Existing MX1 Panels Using the PA1011 Controller

Existing MX1 panels using the PA1011 Controller and original gearplate can be upgraded to support the Remote FBP, multiple MX loops, networking, AS1668 controls and other features available with V1.60 firmware.

For non-networked MX1 panels using the existing PA1011 Controller, the panel can (at most) be upgraded to 4 MX loops, 1000 devices, and 999 zones. The three MX loop cards can be mounted on the existing gearplate.

For networked MX1 panels using the existing PA1011 Controller, the panel can (at most) be upgraded to 3 MX loops, 700 devices, and 999 zones. The two MX loop cards can be mounted on the existing gearplate.

The steps involved in upgrading an existing MX1 are shown in Table 13-1.

If the existing PA1011 Controller is replaced with a PA1081 Controller then the maximum capacity is 8 MX loops, 2000 devices, but the existing gearplate may not have mounting for all the MX Loop Cards and other equipment. Some special drilling and mounting may be required to mount more than 3 MX Loop Cards.

The steps involved are shown in Table 13.1.

Table 13.1 – Upgrading Existing MX1 using the PA1011 Controller

1.	Upgrade the MX1 Controller (PA1011) firmware to V1.60 or higher. MX1 Service Manual (LT0440) Section 5.3 describes this. OR Purchase a PA1081 and replace the PA1011 in the panel. Mounting and wiring is unchanged. Section 7.4 of the MX1 Service Manual (LT0440) covers this. Upgrade the PA1081 firmware to V1.60, if needed. Section 5.3 of the MX1 Service Manual describes this.
2.	Upgrade any existing MX Loop Card firmware to the latest, or purchase a new MX Loop Card (FP0950). MX1 Service Manual (LT0440) Section 5.6 describes the firmware upgrade process.
3.	Upgrade the site specific configuration to V1.60. This is described in LT0440 Section 5.5.5.
4.	Add any additional MX Loop Cards (FP0950). Older gearplates have 3 positions – 2 on the right hand side fold and 1 in the top left hand side – as long as other modules are not fitted there already. If so, special drilling and mounting will need to be done to fit the Loop Cards. Mount and wire to the Controller as per the MX Loop Card Installation Instructions (LT0443).
5.	Program the site specific configuration and re-test as a new system.

13.1.2 Upgrading Existing *MX1* Panels Using the PA1081 Controller

For existing *MX1* panels using a PA1081 Controller the maximum capacity is 8 *MX* loops, 2000 devices, but the existing gearplate may not have mounting for all the *MX* Loop Cards and other equipment. Some special drilling and mounting may be required to mount more than 3 *MX* Loop Cards.

The steps involved are shown in Table 13-2.

Table 13.2 – Upgrading Existing *MX1* using the PA1081 Controller

1.	Check the firmware version in the <i>MX1</i> Controller (PA1081). If less than V1.60 upgrade the firmware to V1.60 or higher. <i>MX1</i> Service Manual (LT0440) Section 5.3 describes this.
2.	Check the firmware version in any existing <i>MX</i> Loop Cards. If less than V2.02 upgrade the firmware to the latest, or purchase a new <i>MX</i> Loop Card (FP0950). <i>MX1</i> Service Manual (LT0440) Section 5.6 describes the firmware upgrade process.
3.	Upgrade the site specific configuration to V1.60. This is described in LT0440 Section 5.5.5.
4.	Add any additional <i>MX</i> Loop Cards (FP0950). Older gearplates have 3 positions – 2 on the right hand side fold and 1 in the top left hand side – as long as other modules are not fitted there already. If so, special drilling and mounting will need to be done to fit the Loop Cards. Mount and wire to the Controller as per the <i>MX</i> Loop Card Installation Instructions (LT0443).
5.	Program the site specific configuration and re-test as a new system.

13.2 Upgrading Existing *MX1* to Networking

13.2.1 Existing *MX1* Panels Using the PA1011 Controller

Existing *MX1* panels using the PA1011 Controller and original gearplate can be upgraded to support networking with V1.60 firmware.

For networked *MX1* panels using the existing PA1011 Controller, the panel can (at most) be upgraded to 3 *MX* loops, 700 devices, and 999 zones. The two *MX* loop cards can be mounted on the existing gearplate.

The existing gearplate may not have mounting for all the networking equipment and some special drilling and mounting may be required. For example to mount the FP1032 OSD139 Fibre Optic Modem bracket the gearplate may require two 3.0mm dia holes to be drilled.

The steps involved are shown in Table 13.3.

Table 13.3 – Upgrading Existing *MX1* for Networking using the PA1011 Controller

1.	Upgrade the <i>MX1</i> Controller (PA1011) firmware to V1.60 or higher. <i>MX1</i> Service Manual (LT0440) Section 5.3 describes this. OR Purchase a PA1081 and replace the PA1011 in the panel. Mounting and wiring is unchanged. Section 7.4 of the <i>MX1</i> Service Manual (LT0440) covers this. Upgrade the PA1081 firmware to V1.60, if needed. Section 5.3 of the <i>MX1</i> Service Manual describes this.
2.	Upgrade any existing <i>MX</i> Loop Card firmware to the latest, or purchase a new <i>MX</i> Loop Card (FP0950). <i>MX1</i> Service Manual (LT0440) Section 5.6 describes the firmware upgrade process.
3.	Upgrade the site specific configuration to V1.60. This is described in LT0440 Section 5.5.7.

4.	Add the required networking equipment such as the I-HUB (FP0771), PIB (FP0986), Moxa Fibre switch, etc. The I-HUB can be mounted on the right hand side fold of the gearplate – as long as other modules are not fitted there already. The PIB can be mounted in 3 positions – 2 on the left of the controller board and 1 on the right hand side fold – as long as other modules are not fitted there already. Refer to Chapter 14 – Networking for further details.
5.	Configure the networking equipment. Note that the I-HUB and PIB come pre-configured to suit most applications. The Moxa fibre modems will require configuring when running in ring mode. Refer to Chapter 14 – Networking for further details.
6.	Configure the network configuration in the <i>MX1</i> panel.
7.	Re-test as a new system.

13.2.2 Existing *MX1* Panels Using the PA1081 Controller

For existing *MX1* panels using a PA1081 Controller the maximum capacity is 8 *MX* loops, 2000 devices.

The existing gearplate may not have mounting for all the networking equipment and some special drilling and mounting may be required. For example to mount the FP1032 OSD139 Fibre Optic Modem bracket the gearplate may require two 3.0mm dia holes to be drilled.

The steps involved are shown in Table 13.4.

Table 13.4 – Upgrading Existing *MX1* for Networking using the PA1081 Controller

1.	Check the firmware version in the <i>MX1</i> Controller (PA1081). If less than V1.60 upgrade the firmware to V1.60 or higher. <i>MX1</i> Service Manual (LT0440) Section 5.3 describes this.
2.	Check the firmware version in any existing <i>MX</i> Loop Cards. If less than V2.02 upgrade the firmware to the latest, or purchase a new <i>MX</i> Loop Card (FP0950). <i>MX1</i> Service Manual (LT0440) Section 5.6 describes the firmware upgrade process.
3.	Upgrade the site specific configuration to V1.60. This is described in LT0440 Section 5.5.7.
4.	Add the required networking equipment such as the I-HUB (FP0771), PIB (FP0986), Moxa Fibre switch, etc. The I-HUB can be mounted on the right hand side fold of the gearplate – as long as other modules are not fitted there already. The PIB can be mounted in 3 positions – 2 on the left of the controller board and 1 on the right hand side fold – as long as other modules are not fitted there already. Refer to Chapter 14 – Networking for further details.
5.	Configure the networking equipment. Note that the I-HUB and PIB come pre-configured to suit most applications. The Moxa fibre modems will require configuring when running in ring mode. Refer to Chapter 14 – Networking for further details.
6.	Configure the network configuration in the <i>MX1</i> panel.
7.	Re-test as a new system.

13.3 Upgrading *MX1* Fan Controls

MX1 panels fitted with an ME0472 AS1668 Fan Control door can be upgraded to V1.60 or later firmware without any changes to the AS1668 door and logic.

If, however, the 2U high ME0472 is to be replaced with a 3U high FP1056 Fan Control door, i.e. to increase the number of controls, then:

- 1U of additional rack space will be required to accommodate the taller FP1056 Fan Control door.
- Either a spare *MX1* Controller 10W serial port (J2, J3 or J4) is required, or access to a 10W serial port on an *MX1* Loop Card.
- All output logic associated with the ME0472 needs to be deleted before programming the fan control logic for the FP1056/FP1057 Fan Controls.

THIS PAGE INTENTIONALLY LEFT BLANK

14 Networking

14.1 Introduction

Multiple *MX1* fire panels, along with other compatible Panel-Link devices, may be connected together to form a network.

Some of the devices which may be part of the network include:

1. *MX1* Fire panels
2. XLG Colour Graphics System
3. QE20 or QE90 Evacuation system
4. NSA Nurse Station Annunciator
5. PMB Panel-Link Modbus Bridge
6. NDU Network Display Unit (for alarms display, event printing and LED mimic displays)
7. MX4428 fire panel as a sub-panel or master panel.
8. F3200 fire panel as a sub-panel or master panel.
9. Compact FF as an alarms display device.

Networking allows *MX1* fire panels to share:

- (i) Alarm information for display and control of alarms on the LCD. Alarms on one *MX1* can be displayed at other panels and Colour Graphics displays. Alarms can be silenced, reset and disabled from the *MX1*s and Colour Graphics displays.
- (ii) Output logic status, allowing status and controls generated by the output logic at one *MX1* to be used by the output logic at another *MX1*, e.g., for extended AS 1668 Fan Controls.
- (iii) MAF Status, so that one *MX1* can be a main brigade display and signalling point for a number of panels on the site.
- (iv) Event Information for status monitoring and network event printing. An *MX1* may be programmed to perform system wide event printing and event history, or from just selected panels.
- (v) Control for activating, disabling and silencing the Alarm Devices on remote *MX1*s as a result of alarms or operator controls on the local *MX1*.

Refer to the *MX1* Network Design Manual LT0564 for detail of how *MX1* interacts with AS4428 and other devices.

An *MX1* panel generally uses either an I-HUB or a PIB as its network interface. A comparison of the features of these is shown in Table 14.1.

Table 14.1 – Comparison between I-HUB and PIB Networks

	I-HUB	PIB
Maximum number of nodes (panels) on the same ring/sub-net	64	64
Can merge ring/sub-nets together	Yes	Yes
Total number of nodes/panels supported over multiple merged rings/sub-nets	64	251
Protocol	Panel-Link	Panel-Link over UDP
Data speed on ring	Up to 57k6	Up to 100M
Additional networking hardware required for ring networking	OSD139HS Fibre Optic modems if fibre is to be used.	Moxa Fibre/Ethernet Switch

	I-HUB	PIB
Ports	2 x RS485 (ring) 2 x RS232 1 x TTL (to <i>MX1</i> Controller Bd)	1 x Ethernet (to Moxa Switch) 1 x TTL (to <i>MX1</i> Controller Bd)
Data cabling - Copper	Twisted copper pair up to 1,500m (depending on cable type and data rate).	Shielded CAT3/5/6 cable up to 100m. Twisted telephone copper pair up to 8km using Westermo Ethernet Extenders.
Data cabling - Fibre	Fibre using OSD139HS Fibre Optic modems. Single Mode fibre up to ~40km, Multi-mode Fibre up to ~3km. Note that the OSD139HS Fibre Optic modems are currently not listed to AS7240.2.	Fibre using Moxa switch. Single Mode fibre up to 40km, Multi-mode Fibre up to 5km.

The following sections give a brief description of using these devices, plus a direct connection to certain devices.

14.2 I-HUB

The I-HUB is used to connect the *MX1* panel onto a RS485 or fibre optic ring network (see Figure 14.1), or a multi-drop bus network (see Figure 14.2), or an arbitrary arrangement of connections. It has five network ports, one of which is used as the I-HUB programming port. Each network port can be connected to a network of devices or to a single device. The I-HUB performs bridging and routing functions for the Panel-Link network and *MX1*. Panel-Link messages received on one port can be routed to any or all of the other ports. This allows the physical size of a Panel-Link system to be extended, or multiple Panel-Link networks to be joined together, and also allows devices on different physical media to be connected.

Two of the I-HUB ports are 2 or 4 wire RS485 connections that usually operate in tandem as a ring network (they cannot be configured to operate independently). By adding external fibre modems to segments of the ring, the ring can be run in fibre optic cable. A further two ports provide RS232 levels. If required, these may be connected to a variety of external interface boards that convert RS232 levels to RS485, or to modems.

The fifth port is a TTL level serial port that is connected to the *MX1* Controller in a *MX1* panel, or to compatible ports in other Panel-Link products.

Figure 14.1 shows the general arrangement of panels and I-HUBs in a ring network. This is the recommended networking arrangement as it results in the least cable, offers a higher level of fault redundancy, and supports more devices. Furthermore the I-HUB is factory configured for operation on a ring with an *MX1* connected to port 5, so for many situations no programming of the I-HUB will be required. Any QE20 will need the RS485 Network Kit included.

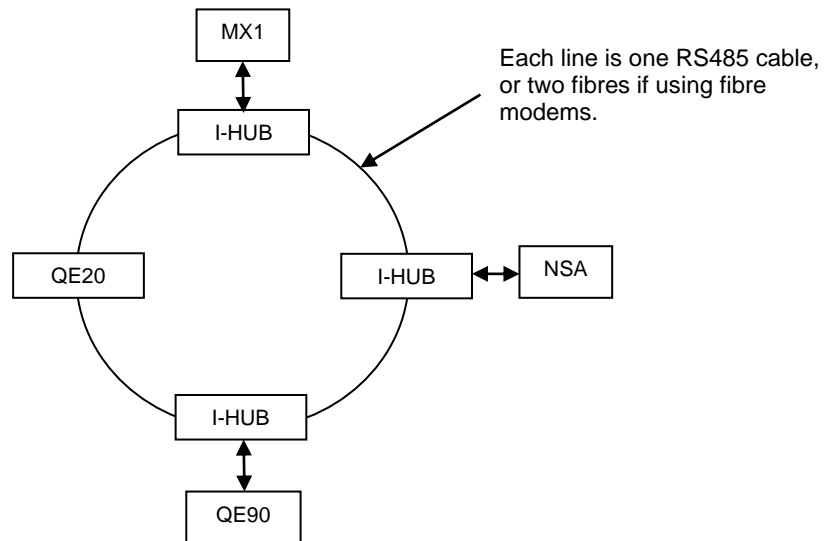

Figure 14.1 – I-HUB in ring topology

Figure 14.2 shows the general arrangement of a dual bus network. The I-HUB can be configured for this to suit certain legacy installations, but it requires programming of the I-HUB, and so is not recommended for new installations. Note a QE20 cannot be used on a multi-drop network.

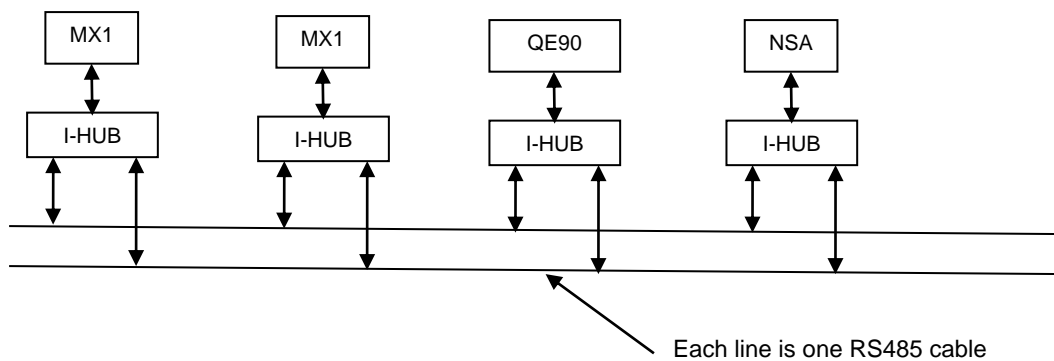

Figure 14.2 – I-HUB in Multi-Drop Topology

Refer to AS 1670.1:2018 s3.25 and s3.26 for network cabling protection requirements.

By specially configuring one or more I-HUBs they can be arranged for arbitrary network arrangements to join various panels/media connections together. As this is a specialist application, please refer to the I-HUB User Manual (LT0229) for details.

Ordering Codes

The I-HUB is ordered as:

FP0771 F3200/F4000 I-HUB Upgrade Kit

This provides the I-HUB, mounting facilities and cables to mount the I-HUB in the cabinet and connect to the MX1 using the I-HUB’s port 5. If fibre optic cables are required the FP1032 kit can be ordered to provide mounting of two OSD fibre modems, e.g., for the ring cabling or star connected sub panels. Note that the OSD fibre modems are currently not ActivFire listed to AS 7240.2.

- FP1032 OSD139 Fibre Optic Modem x 2 Mounting Kit**
- OSD139HS Fibre Optic Modem Multi-Mode**

OSD139HSL Fibre Optic Modem Single-Mode I-HUB Mounting

The I-HUB (FP0771) is usually mounted on the right hand wall of the 8U cabinet, or on the right hand gearplate flange of the 15U cabinet (see Figure 14.3). Note that you will have to remove the 15U gearplate from the cabinet to mount the I-HUB using four M4 screws.

Optional OSD fibre modems can be mounted on the *MX1* gearplate in place of *MX1* Loop Cards by using the FP1032 OSD139 Fibre Optic Modem Bracket.

Note: When using fibre cabling you must allow for cable entry and the minimum bend radius in deciding the cable route to the modems (commonly 60-90mm for field cables, 40mm for patch leads).

Refer to the gearplate drawings in Chapter 8 Miscellaneous Applications for other mounting options.

Documents

For further details regarding the I-HUB please refer to:

LT0229 Panel-Link I-HUB User Manual



**Figure 14.3 –
I-HUB Mounted on 15U
Gearplate RHS Flange**

14.3 PIB (Panel-Link IP Bridge)

The PIB can be used to interconnect *MX1* panels over an IP network or to extend a Panel-Link network over long distances or between locations where it is not convenient or economic to install the cable normally used for Panel-Link, but where an IP network is available.

Multiple PIBs at different physical locations can be connected to an IP network (either the customer's existing network (non-approved installations), or a network installed specifically for the purpose). In very simple terms, the PIBs act as a "piece of wire" between these locations.

Each PIB transmits the messages it receives from the connected Panel-Link device via the IP network to all the other PIBs it knows about. Each receiving PIB sends an acknowledge message back to the sending PIB and also transmits the Panel-Link message out on its Panel-Link port.

The *MX1* is ActivFire listed to AS 7240.2 with the following IP networking products:

FP0986	FP PIB PANEL-LINK IP BRIDGE
SU0319	MOXA 5 PORT E/NET SW (2 MULTI MODE FIBRE)
SU0320	MOXA 5 PORT E/NET SW (2 SINGLE MODE FIBRE)
SU0328	WESTERMO SHDSL ETHERNET EXTENDER DDW-120
FP1012	<i>MX1</i> DIN MODULE MOUNTING BRACKET
FP1013	MX4428/F3200 IP NETWORKING BRACKET

This allows an IP network using a ring of single-mode or multi-mode optical fibre cable, screened twisted pair CAT3/5/6 cable (100m distance limit) and/or copper pair cable using Ethernet Extenders to be achieved.

Refer to AS 1670.1 s3.25 and s3.26 for network cabling requirements.

Other media types are available (from other suppliers) for non-standards compliant systems. For example:

- Wireless (WiFi, WiMax, Microwave, GPRS, 3G, etc.).
- DSL (DSL, ADSL, ADSL2, ADSL2+, etc.).

Also, multiple topologies (star, redundant ring, etc.) are supported by third party equipment.

Figure 14.4 shows a diagram of a fully redundant ring network. Each network 'node' includes a PIB and a Moxa Switch (with 2 Fibre ports if applicable). If any one of the segments is broken, the switches will re-direct data as required so that communication will continue unimpeded. Furthermore, each of the switches can be configured to output a fault signal when this happens so that the fault can be identified, diagnosed and repaired.

Note QE20 supports only fibre networking on an IP ring.

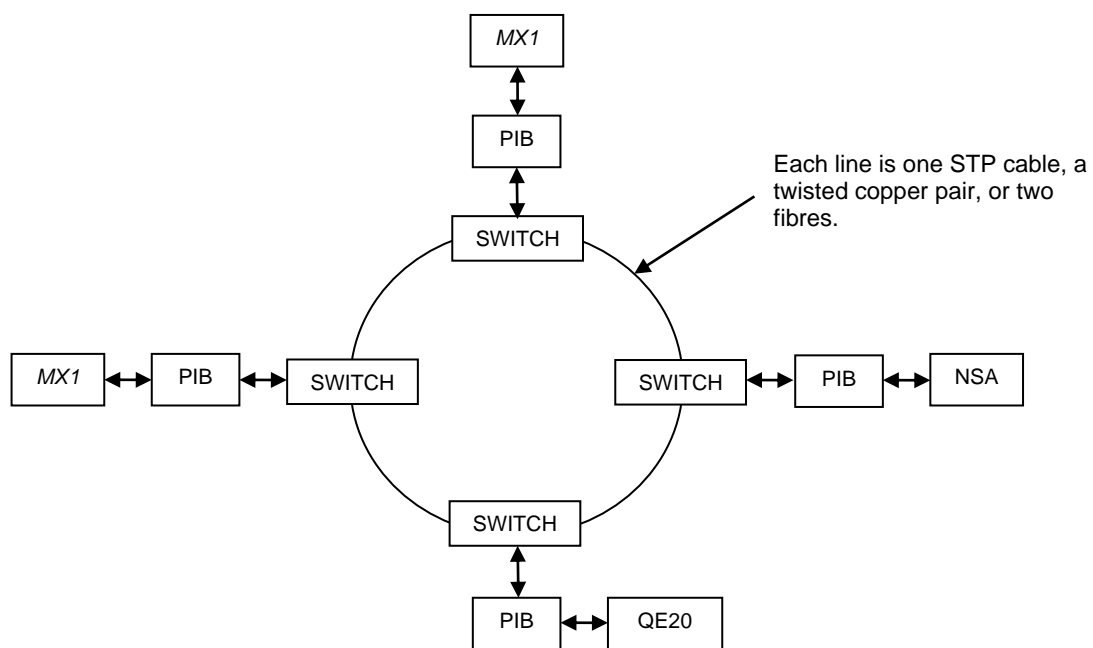

Figure 14.4 – Fully Redundant Ring Topology

Ethernet extenders can be used to send IP data over a twisted pair. An Ethernet extender is required at each end of the link, as shown in Figure 14.5.

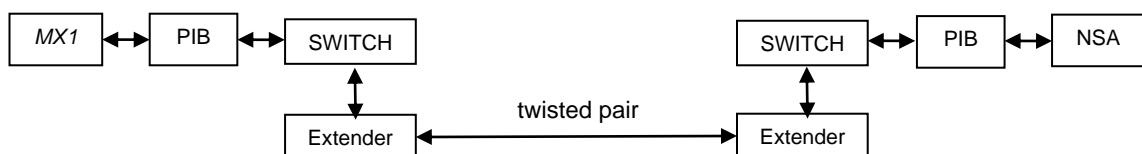

Figure 14.5 – Ethernet Extenders

Depending on the cable type used, the Westermo DDW-120 Ethernet extender can support sending data over a twisted pair cable up to 5-8km in length.

Each PIB can connect directly to one Panel-Link device that supports point-to-point mode (i.e., MX1, I-HUB, PMB, NDU, NSA, QE20, QE90, or XLG colour graphics interface).

PIB Mounting

The PIB (FP0986) is required to be earthed and the recommended earthing method is via 2 metal standoffs (J17 and J19) in the positions shown in Figure 14.6. The other standoffs may be plastic or metal. If J17 and J19 are not earthed this way, then earth leads (included with the PIB) must be fitted to the adjacent earth tabs J23 and J25, with the leads electrically connected to the gearplate/cabinet earth.

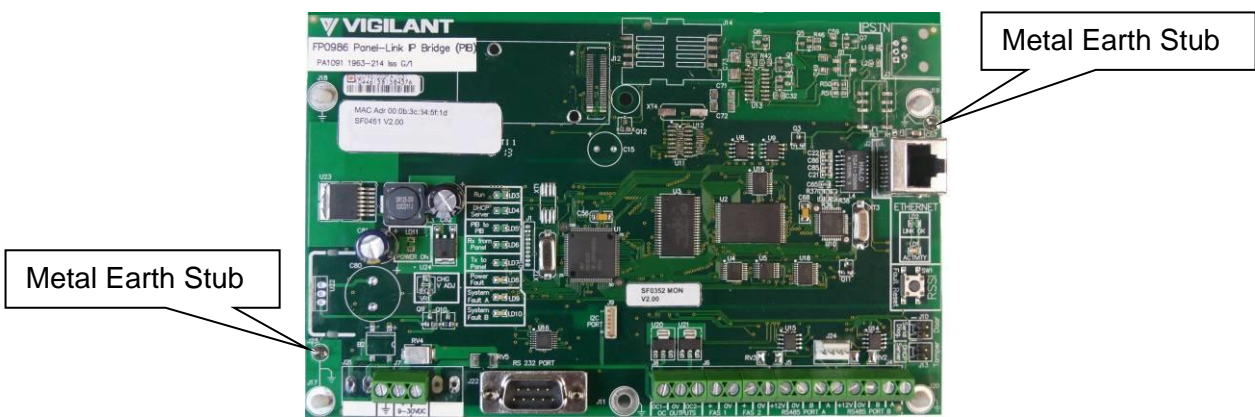

Figure 14.6 – PIB Earthing

Figure 14.7 shows the mounting of the PIB in the 8U cabinet with a Moxa switch mounted on the FP1013 mounting bracket.

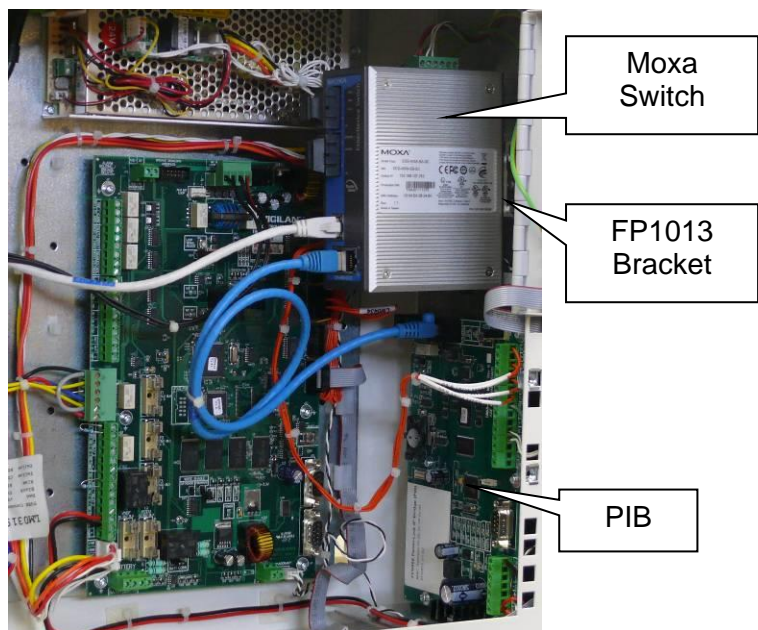

Figure 14.7 – 8U Cabinet PIB Mounting

Figure 14.8 shows the 3 mounting positions for the PIB on the 15U gearplate. Position 1 is recommended because it provides the required earth facilities.

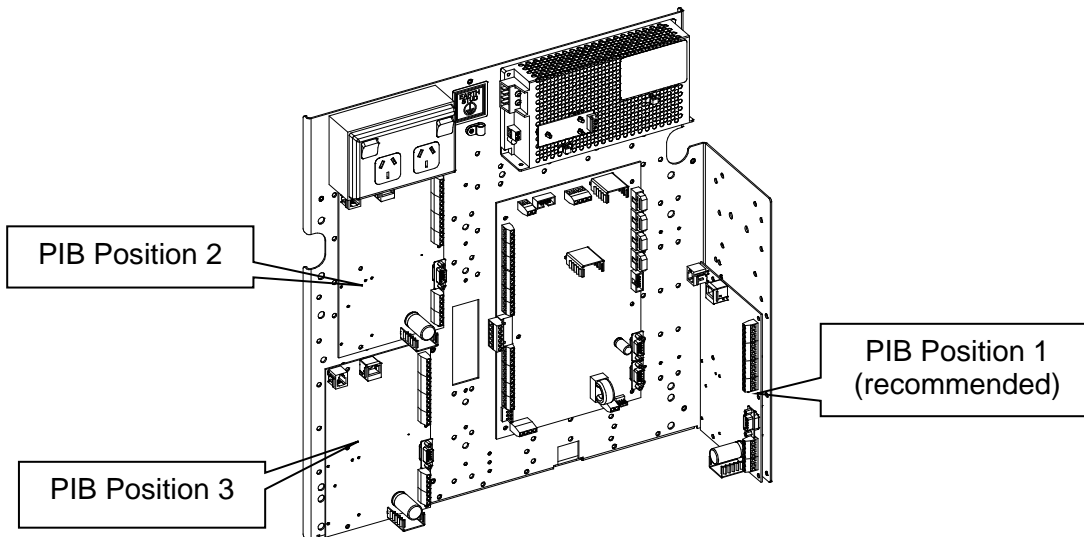

Figure 14.8 – 15U Cabinet PIB Mounting Positions

When mounting the PIB in position 2, earth leads will need to be fitted between earth tabs J23 and J25 and the gearplate. When mounting the PIB in position 3 an earth lead will be required to be fitted between earth tab J25 and the gearplate. No earth lead is required for J23 as there is a metal standoff on the gearplate.

A Moxa switch and one Ethernet extender (or 2 Ethernet extenders) can be mounted using one FP1012 mounting bracket. This bracket is mounted on the left side of the gearplate, as shown in Figure 14.9. Note the Moxa switch needs to be earthed to the cabinet via the earth screw on its top, and the Ethernet extender requires 10mm of clear air around it for ventilation.

It is also possible to mount the PIB and the FP1012 in the same position to allow room for other devices such as *MX* Loop Cards. But in this case only the Moxa switch or an Ethernet Extender can be mounted on the FP1012 bracket and the PIB LEDs will not be visible.

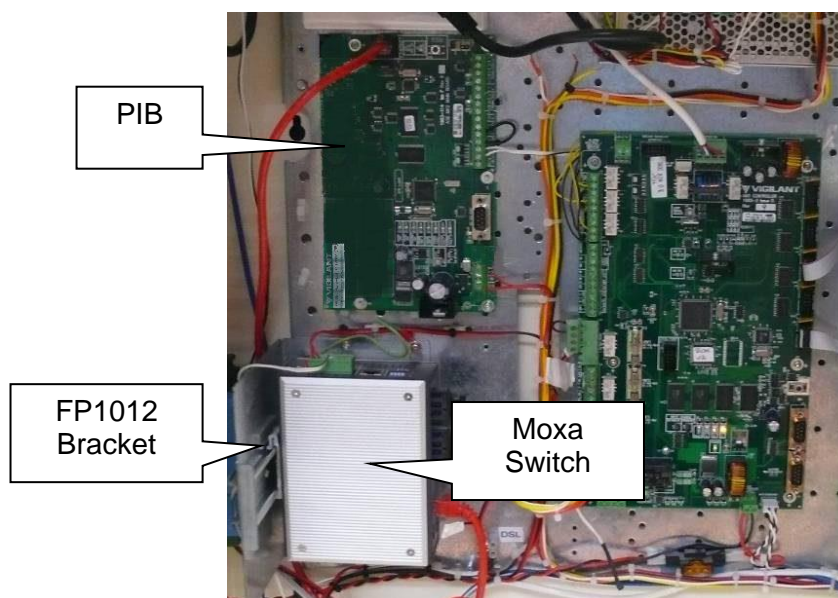

Figure 14.9 – 15U Cabinet PIB Mounting Options

Note: When using fibre cabling you must allow for cable entry and minimum bend radius in deciding the fibre cable route to the switch (commonly 60-90mm for field cables, 40mm for patch leads).

Refer to the gearplate drawings in Chapter 8 Miscellaneous Applications for further details regarding mounting options.

Documents

For further details on the PIB please refer to:

LT0519 PIB User Manual

14.4 Direct Connection

The MX1 panel has one TTL level serial port that supports point to point Panel-Link with one other Panel Link device such as the PMB. This device must usually be located in the MX1 cabinet and be powered by the MX1 as the TTL level port is not suitable for connections outside the cabinet. Refer to the PMB User Manual (LT0202) for further details.

14.5 Programming

The MX1 is configured for networking using the SmartConfig program.

Note that this section is an overview of the basic networking programming required by the MX1. Please refer to the MX1 Network Design Manual LT0564 for more detail.

There are 3 main tables used to configure networking:

14.5.1 Hardware Table

In the hardware table (Figure 14.10) you must set the Network Function to either I-HUB, PIB, or Other (e.g., direct connection), and the Port to the serial port number on the MX1 controller board used to connect to the network interface device (e.g., I-HUB or PIB).

Equip Address	Available Functions	Link 1	Link 2	Function	Profile	Port	Text
1	Onboard MX Loop 1	Loop 1 Devices →		On-board Loop			
2	MX Loop 2			None			
3	MX Loop 3			None			
4	MX Loop 4			None			
5	MX Loop 5			None			
6	MX Loop 6			None			
7	MX Loop 7			None			
8	MX Loop 8			None			
241	Controller	controller →		Local I/O			
242	Pseudo Points	Pseudo →		Pseudo Points			
243	Keypad	Keypad →		Keypad			
244	RZDU	RZDU →		RZDU		Port 0	
245	Equip Points	Equip →		Equip Points			
246	Remote FBP			None			
247	Network	Network →	SID Points →	PIB	38400 bps, PIB	Port 4	
248	DSS			None			

Figure 14.10 – Hardware Table

247	Network	Network →	SID Points →	PIB ▼	38400 bps, PIB ▼	Port 4 ▼
-----	---------	-----------	--------------	-------	------------------	----------

Figure 14.11 – Hardware Table (PIB configuration example)

247	Network	Network →	SID Points →	I-HUB ▼	38400 bps, I-HUB ▼	Port 3 ▼
-----	---------	-----------	--------------	---------	--------------------	----------

Figure 14.12 – Hardware Table (I-HUB configuration example)

14.5.2 System Table

In the system table (Figure 14.13) there are two network related settings: SID Number and Local Network Profile.

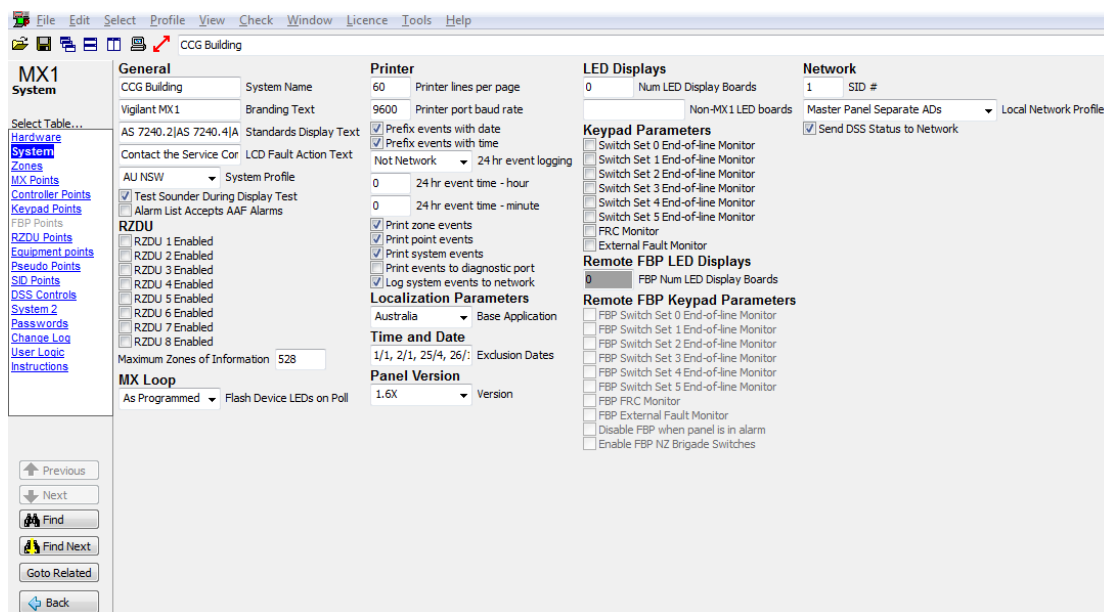

Figure 14.13 – System Table

SID Number

The SID number is used to identify each Panel-Link device (e.g., MX1 Panel) on the network, and so each device on the same network must have a unique SID number.

Local Network Profile

Profiles provide a collection of settings commonly adjusted "in bulk" to configure an MX1 for suitable operation in different jurisdictions and for different applications. Figure 14.14 shows the Local Network Profiles available in SmartConfig.

Master Panel

A master panel can display and log events from other panels, and control them. It sends its time out on the network to synchronise the clocks on other panels. Note that as well as selecting the network profile you must also enter all the panels you wish the master to interact with in the SID Points table.

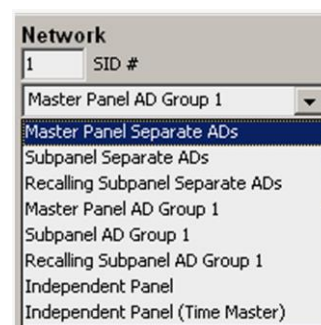

Figure 14.14 – Local Network Profiles

Subpanel

A subpanel displays and logs only local events, and cannot control other panels. Its information is sent out for other panels to use. Its SID Point table should contain the master panel required to control it.

Recalling Subpanel

A recalling subpanel is similar to a subpanel but can also receive and recall events from other panels. Its SID Point table should contain the master panel and the other panels it is to receive and recall events from.

Separate ADs

With separate ADs (Alarm Devices) the alarm devices on each panel will operate independently to the alarm devices on other panels.

AD Group 1

With AD Group 1, alarm devices on panels in group 1 will all turn on together and will be silenced together. Panels in group 1 can silence the alarm devices on other panels in group 1, but only if they are showing an alarm in their Fire Brigade panel alarm list and its alarm devices are on.

Independent Panel

An independent panel does not interact with any other panels on the network. For example the panels might be networked to a Colour Graphics System.

Independent Panel (Time Master)

An independent time master is an independent panel that sends its time out on the network to synchronise the clocks of other panels.

For detailed information on the network profiles please consult the *MX1 Network Design* manual LT0564.

14.5.3 SID Points Table

The SID Points table is used to enter the details of the other Panel-Link devices on the network that this panel is required to interact with.

Each row is one network device, with the point number equal to the device's SID number. E.g., row 5.0 relates to the device with a SID of 5.

Each network device is configured with:

- its device type (e.g., *MX1*, *XLG*, *QE90*, etc)
- a SID Config Profile. The profile options will depend on the device type.

Each network device will have 1 or more sub points depending on its type. For each sub point you can configure the point text, if the point can be disabled, the logging profile and Point Flags profile.

In the following example there are three *MX1* panels in a ring network using PIBs. There is a master panel with a SID of 1 and two subpanels with SIDs of 4 and 7. The master can see local events and events from both subpanels, and can control the subpanels. The subpanels can see only local events, but must generate a fault if the connection to the master panel fails.

In the SmartConfig SID Points table for the master panel (SID 1) the two subpanels are entered as shown in Figure 14.15. Entering the subpanel in the master's SID Points table allows the master panel to receive events from the subpanel (e.g., alarms, faults, etc), control the subpanel and monitor the link to the subpanel.

Point (Equip 247)	Type	Name	SID Config Profile	Point Desc	Pt Text	Can be disabled	Logging Profile	Point Flags Profile	Notes
1.1	MX1	CCG Building		SID MAF Status	Local MAF Status				
2.0	None								
3.0	None								
4.0	MX1	Building G	Subpanel	SID Comms Status	SID Comms Status	<input checked="" type="checkbox"/>	Log All	Map Fault to Brigade, no test	
4.1				SID MAF Status	SID MAF Status	<input checked="" type="checkbox"/>	Log All	Off nml recal no test	
5.0	None								
6.0	None								
7.0	MX1	Building D	Subpanel	SID Comms Status	SID Comms Status	<input checked="" type="checkbox"/>	Log All	Map Fault to Brigade, no test	
7.1				SID MAF Status	SID MAF Status	<input checked="" type="checkbox"/>	Log All	Off nml recal no test	
8.0	None								
9.0	None								
10.0	None								
11.0	None								
12.0	None								
13.0	None								
14.0	None								
15.0	None								
16.0	None								

Figure 14.15 – SID Points Table in MX1 Master

In the SmartConfig SID Points table for each subpanel (SIDs 4 & 7) the master panel (SID 1) is entered as shown in Figure 14.16. Entering the master panel in the subpanel’s SID Points table allows the master panel to control it and the subpanel to monitor the link to the master panel.

Point (Equip 247)	Type	Name	SID Config Profile	Point Desc	Pt Text	Can be disabled	Logging Profile	Point Flags Profile	Notes
1.0	MX1	CCG Building	Master Panel	SID Comms Status	SID Comms Status	<input checked="" type="checkbox"/>	Log All	Map Fault to Brigade, no test	
1.1				SID MAF Status	SID MAF Status	<input checked="" type="checkbox"/>	Log All	Off nml recal no test	
2.0	None								
3.0	None								
4.1	MX1	Building G		SID MAF Status	Local MAF Status				
5.0	None								
6.0	None								
7.0	None								
8.0	None								
9.0	None								
10.0	None								
11.0	None								
12.0	None								
13.0	None								
14.0	None								
15.0	None								
16.0	None								
17.0	None								

Figure 14.16 – SID Points Table in a Sub-Panel

There are many other configurations you can use. For further details on configuring the SID Points please consult the MX1 Network Design manual LT0564.

15 Appendices

15.1 Appendix A - Associated Documentation

15.1.1 Other *MX1-Au* Manuals

The following additional manuals are available for *MX1* for add-on equipment:

LT0229 I-HUB User Manual	Design, Installation, Configuration and using the I-HUB.
LT0332 SmartConfig PLUS User Manual LT0468 SmartConfig User Manual	Provides details on creating and downloading an <i>MX1</i> datafile using the SmartConfig program.
LT0439 <i>MX1-Au</i> Operator Manual	Describes the use of the front panel display and keyboard.
LT0440 <i>MX1-Au</i> Service Manual	Detailed maintenance and service information for <i>MX1</i> .
LT0442 <i>MX1-Au</i> Field Wiring Instructions	Wiring diagrams for each <i>MX</i> Loop device and the connection of common devices to the <i>MX1</i> Controller.
LT0443 <i>MX</i> Loop Card Installation Instructions	Installation instructions for the <i>MX</i> Loop Card.
LT0519 PIB User Manual	Design, Installation, Configuration and using the PIB.
LT0532 Remote FBP Installation Instructions	Installation and wiring instructions for the Remote FBP.
LT0547 FP1012 Installation Instructions	Installing the FP1012 bracket.
LT0551 FP1013 Installation Instructions	Installing the FP1013 bracket.
LT0557 <i>MX</i> Loop Card/Module Install Instructions	Installation instructions for the FP1027 <i>MX</i> Module mounting bracket.
LT0563 FP1032 Installation Instructions	Installing the FP1032 bracket and wiring OSD fibre optic modem.
LT0564 <i>MX1</i> Network Design Manual	Details for designing and configuring <i>MX1</i> networks.
LT0587 FP1056/FP1057 Installation Instructions	Installing the FP1056 3U Door and Fan Controls.
LT0591 <i>MX1</i> 4 x DDM Mounting Bracket Install Instructions	Installing the FP1062 and FP1063 4 x <i>MX</i> Module Brackets

15.1.2 Other Documents

These documents are referred to in this manual and contain more detailed information about the use of these specific products.

17A-03-VLC – Installation Commissioning and Servicing of the VLC-800 sensor

17A-13-D – System 800 Intrinsically Safe *MX* Addressable Fire Detection System

17A-02-ISLOOP – *MX* Intrinsically Safe System – Loading Calculations

S200+ Series Triple IR Flame Detectors User Manual

120.515.123 FLAMEVision FV400 Series – Triple IR Flame Detectors Product Application and Design Information Manual

120.515.124_FV-D-400-F FV400 Series Triple IR Flame Detectors Fixing Instructions

120.515.203 – FLAMEVision FV421i IS Triple IR Flame Detector Product Application and Design Information Manual

120.515.204 – FV421i IS Triple IR Flame Detector Fixing Instructions

LT0088 QE90 Installation Manual

LT0206 TPI User Manual

LT0726 QE20 System Design Manual

Additionally each *MX* module and most add-on modules for the *MX1* have their own installation or user guide.

User Manuals are also available for the third party networking products: Moxa fibre switch, Westermo Ethernet Extender and OSD fibre modems.

15.2 Appendix B – Glossary of Terminology

The following terminology is used in this manual:

Alarm Device	Audible or visual device for warning building occupants of a fire alarm.
Analogue Loop	The wiring that allows an <i>MX1</i> to communicate with and supply power to the addressable devices and detectors.
Ancillary Equipment	Equipment external to the System that is controlled by the Fire Alarm System
Ancillary Relay	Relay to switch ancillary equipment.
ASE	Alarm Signalling Equipment
Baud	Bits per second.
Control Output	Output from Fire Alarm System to other equipment.
Default	Pre-programmed option or logic equation, i.e., one that exists without the user configuring or programming it.
Detector	Addressable device used to detect fires that interfaces to the <i>MX1</i> via the Analogue Loop. It contains one or more sensors.
Evacuation (tone)	Tone pattern produced by an alarm device intended to instruct building occupants to evacuate the building.
IS	Intrinsically Safe
Mapping	Programmable causal relationship between inputs and outputs.
Module	Addressable I/O device that interfaces to the <i>MX1</i> via the <i>MX</i> Loop.
Point	A representation of a part or component of the fire alarm system, e.g., an addressable device (detector or module) with a unique address that is connected to the <i>MX</i> loop, a relay output, or an internal part of the control equipment such as a fuse.
Sensor	Part of a detector which senses the environment, e.g., smoke or temperature or CO level.
SID	A unique number in the range 1-254 (address) allocated to each panel or device on the network.
Zone	Fire searchable area of building represented by a unique number and name in the Fire Alarm System.

15.3 Appendix C – Glossary of Abbreviations

AAF	Alarm Acknowledgement Facility
AC	Alternating Current.
ADF	Alarm Delay Facility
ACZ	Ancillary Control Zone.
AL	Alarm Load (of the fire alarm system)
AVF	Alarm Verification Facility, or alarm check.
CV	Current Value (Filtered reading from detector)
DC	Direct Current.
DSS	Distributed Switch System (Control & Indication system on MX1)
ELD	End of Line Device
EWIS	Emergency Warning and Inter-communication System
FIP	Fire Indicator Panel
LCD	Liquid Crystal Display (usually alphanumeric)
LED	Light Emitting Diode (Visual Indicator).
MCP	Manual Call Point (break glass switch).
NA	Not Applicable.
NAL	Non-alarm load (of the fire alarm system)
NBL	Non-battery load (system load powered by only the power supply, not the battery)
NC	Normally Closed, Relay Contact.
NO	Normally Open, Relay Contact.
O/C	Open Circuit.
PCB	Printed Circuit Board.
PSTN	Public Switched Telephone Network.
PSU	Power Supply Unit.
RZDU	Remote Zone Display Unit.

Manufactured by: Johnson Controls
 17 Mary Muller Drive, PO Box 19-545
 Christchurch, New Zealand
 Tel +64-3-389 5096
 Fax +64-3-389-5938