

Vigilant *MX1-Au*

Fire Alarm System

Wiring Diagrams

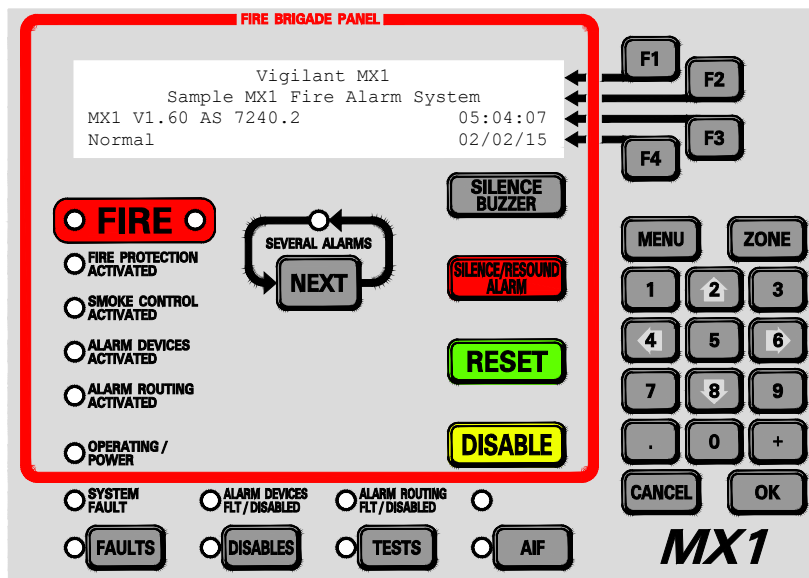

LT0442
Issue 1.98

Cautions & Warnings



100V a.c. audio line wiring is defined as LV Telecommunications circuits and is subject to the Australian Standard AS/ACIF S009:2006. Ensure that this wiring is appropriately separated and insulated from LV power wiring, ELV and other customer cabling such as detection and control circuits.



The internal circuit cards may be damaged by static electricity when handled. Ensure you are wearing an earthed ESD strap when installing the *MX1* circuit cards.



Ensure all power is turned off when connecting/disconnecting internal and field wiring as damage may occur if wrong or partial connections are made with power applied.

Document History:	29 July 2009	Issue 1.12	Sheet 123 updated
	10 Nov 2009	Issue 1.13	Sheet 147 updated
	1 Feb 2011	Issue 1.20	Multi-MX loop changes. Sheets 130, 148, 149 & 1982-88 added. Sheets 103, 116, 121, 124, 128, 140-144 revised. Sheet 146 deleted
	13 June 2011	Issue 1.30	Sheet 149 updated
	16 Nov 2011	Issue 1.40	Sheets 128, 143, 145, 148 amended
	30 May 2012	Issue 1.50	Sheet 147 and Drawing 1982-88 updated
	4 Oct 2013	Issue 1.60	Updated for networking and 8U cabinet.
	5 Nov 2013	Issue 1.70	Sheets 153 and 157 amended.
	11 April 2014	Issue 1.80	Sheets 150 amended.
	9 March 2015	Issue 1.90	Sheet 143 amended, Sheets 132, 161 to 165 added.
	11 Nov 2015	Issue 1.91	Sheet 1982-210 Sheet 2 added.
	30 March 2016	Issue 1.92	Sheet 1982-210 Sheet 2 updated.
	19 July 2017	Issue 1.93	Sht 166, 167, 168 added.
	21 November 2017	Issue 1.94	Shts 133, 134, 135 & 169 added, 115 & 152 updated. 1982-88 updated.
	16 October 2018	Issue 1.95	Shts 136, 137 & 138 added, 134, 161, 163 & 169 updated.
	8 February 2019	Issue 1.96	Sht 118 updated, 170 added.
	12 May 2020	Issue 1.97	Shts 111, 115, 121, 162, modified. Shts 171, 172, 173, 174 added.
	24 March 2023	Issue 1.98	Sheet 139 added.

General

Each of these diagrams (most in the 1982-71 series) shows the wiring for a particular module, card or base which can be used with the MX1-Au fire alarm system.

Drawing Index

Sheet	Title	Revision
Bases		
101	Not yet published	-
102	4B/5B Base	B
103	4BI/5BI Isolator Base	C
104	814RB Relay Base	A
105	4B-C Continuity Base	A
106	802SB/901SB Sounder Base	A
168	D51MX Duct Sampling Unit (with 4B-C)	A
171	80DSB Sounder Base	A
172	P80SB, P80AVB, P81AVB Addressable Sounder/VAD Bases	A
Modules		
107	DIM800 Detector Interface Module	A
108	MIM800 Mini Input Module	A
109	CIM800 Contact Input Module	A
110	MIO800 Multi I/O Module	A
111	SNM800 Sounder Notification Module	B
112	RIM800 Relay Interface Module	A
113	LPS800 Loop Powered Sounder Module	A
114	VLC800MX Vesda LaserCompact Interface	A
115	CP820/830, MCP820/830, MCP821/831 Call Points	C
116	LIM800 Loop Isolator Module	B
117	S271f+ Flame Detector	A
118	Intrinsically Safe Devices	B
119	VIO800 (MIO800) LaserPlus/Scanner	A
161	QIO850 Quad I/O Module	B
162	QMO850 Monitored Output Module	B
163	QRM850 Quad Relay Module	B
164	DDM800 Dual Detector Module, Loop Powered	A
165	DDM800 Dual Detector Module, Externally Powered	A
166	SIO800 Single Input/Output Module	A
167	FV400 Series Flame-Proof Detector	A
170	FV421i Intrinsically Safe Detector	A
173	P80AVR/P80AVW Sounder/VAD	A
Ancillary Devices		
120	AAM2 Module	A
121	ANC2 External Alarm	C
122	Mini-Gen to MX1 Anc 3	A
123	T-Gen 50 to MX1 Anc 1	B
124	ISO8201 Strobe Driver to MX1 Anc 3	B
125	16 Way Protected Inputs	A
126	16 Way Relay or Open Collector O/Ps	A
127	QE90 "RZDU" I/F	A
128	MX1 Loop Card	C
129	MIM801 Mini Input Module (NZ use)	A
130	Remote FBP	C
131	PA0915 Fuse Board	A
132	AS1668 Fan Controls	A
133	T-Gen 60 to MX1 Anc 1	A
134	Single T-Gen 60/120 to 100V Switching Module	B
135	T-Gen 60/120 to 100V Splitter Module	B
136	High Level Interface (HLI) Module	A
137	Dual T-Gen 60/120 to 100V Switching Module	A
138	Triple T-Gen 60/120 to 100V Switching Module	A
139	QE20 RZDU Interface	A

174	ANC3 to Conventional Sounders/VADs	A
15U Gearplate Layouts		
140	T-Gen 60, MX Modules, MX Loop Card	B
141	Mini-Gen, Strobe Driver	C
142	16 Input, 16 Output, MX Loop Card	B
143	16 Way Relay Board, MX Loop Cards (Bracket Mounted)	D
144	PIB IP Networking Equipment	C
148	General Purpose SGD, RS485 Board, Fuse Board	C
149	I-Hub / Fibre Modems	C
169	T-Gen 60, 100V Switching/Splitter Modules	B
Networking		
150	I-Hub RS485 / Fibre Ring Network	B
151	IP Networking Wiring Details	A
8U Gearplate Layouts		
152	T-GEN 60, MX Modules	B
153	SGD, Mini-Gen / Strobe	B
154	MIO800, Future Gas Card	A
155	General Purpose Relay	A
156	MX Loop Card	A
157	STP Bracket, Loop Card Bracket, MX Module Bracket	B
158	FP1012, Moxa & Ethernet Extender	A
159	FP1013, Moxa & Ethernet Extender	A
160	I-HUB / Fibre Optic Modems	A
Brigade Kits		
145	MX1 WA ASE Wiring	B
147	MX1 Centaur & Centaur II ASE Mounting & FAS Wiring Details	C
1982-210-2	MX1 NTFAS Brigade I/F Wiring Details	B
Extra Information		
1982-88	MX1 Zone LED Board Cabling	D
1922-98	Centaur Resistor Colour Code	A

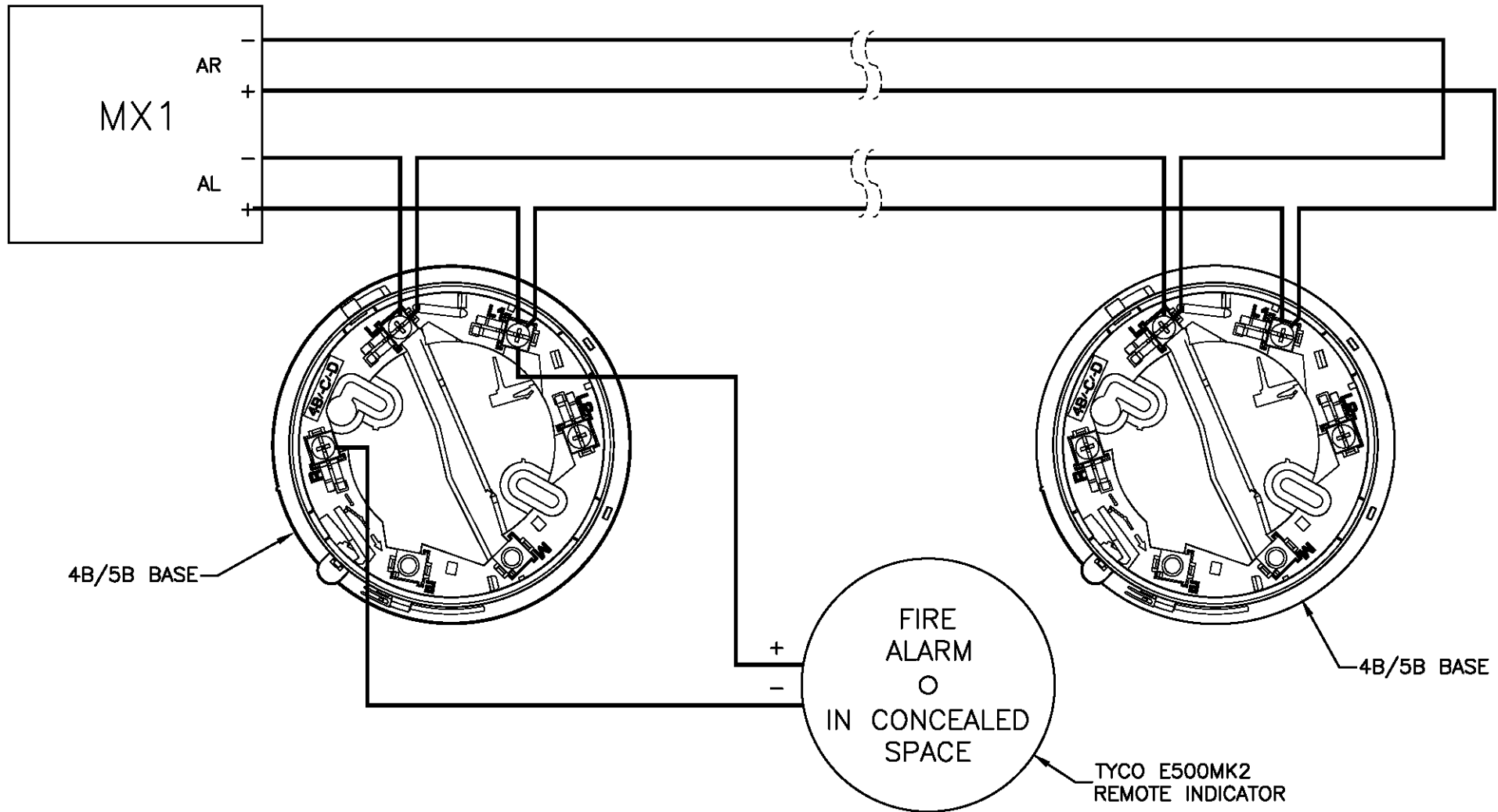

CONFIDENTIAL: THIS DOCUMENT MUST NOT BE COPIED NOR THE CONTENTS PASSED ON TO ANY THIRD PARTY WITHOUT THE CONSENT OF THE COMPANY.

UNLESS OTHERWISE STATED: ALL DIMENSIONS IN MILLIMETRES. DO NOT SCALE. TOLERANCES ARE TO BE: 1 DECIMAL PLACE ±0.5, 2 DECIMAL PLACES ±0.3, 3 DECIMAL PLACES ±0.1

3rd ANGLE PROJECTION

ISS/REV	AMENDMENTS	ECO	DRN	CHKD	AUTH	APVD	DATE
A	ORIGINAL	-	KJS	RAC	RAC	DSCP	20-8-08
B	4B BASE ADDED.	-	KJS	JP	RC	DP	4-10-13

tyco
Fire Protection Products

TYCO FIRE PROTECTION PRODUCTS
17 MARY MULLER DRIVE
P.O. BOX 19545
CHRISTCHURCH, PH: +64 3 3895096
NEW ZEALAND. FAX: +64 3 3895938

MX1 4B / 5B BASE WIRING DIAGRAM			
DRAWING No: 1982-71		SHEET 102 of N	
A3	ISS/REV B	PART No:	

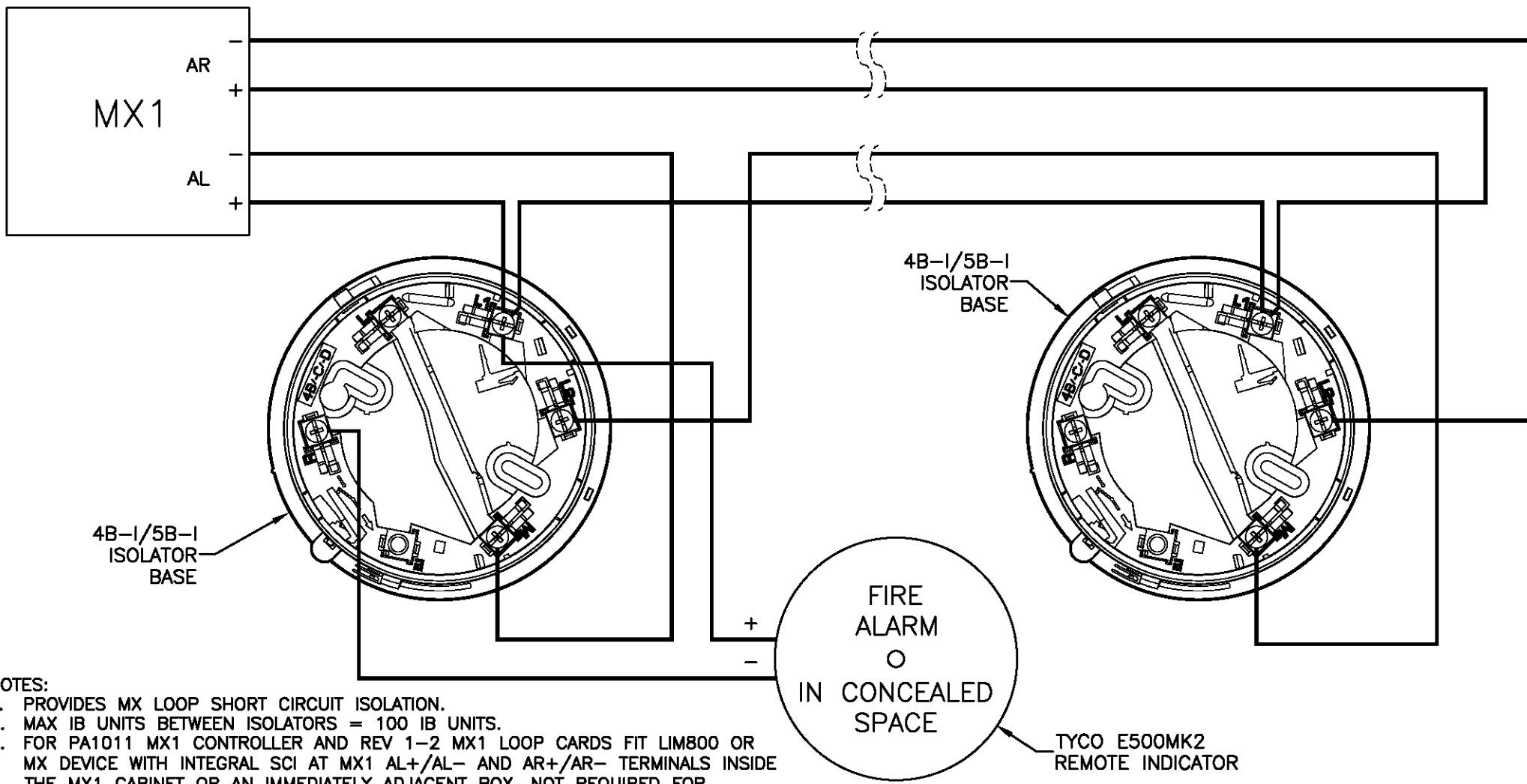

NOTES:

1. PROVIDES MX LOOP SHORT CIRCUIT ISOLATION.
2. MAX IB UNITS BETWEEN ISOLATORS = 100 IB UNITS.
3. FOR PA1011 MX1 CONTROLLER AND REV 1-2 MX1 LOOP CARDS FIT LIM800 OR MX DEVICE WITH INTEGRAL SCI AT MX1 AL+/AL- AND AR+/AR- TERMINALS INSIDE THE MX1 CABINET OR AN IMMEDIATELY ADJACENT BOX. NOT REQUIRED FOR PA10B1 OR REV 3 ONWARDS LOOP CARDS.
4. NO MORE THAN 40 DEVICES (MX DETECTORS/MODULES + ACTUATING DEVICES ON CIM/DIM/MIM/MIO INPUTS AND EACH SEPARATE OUTPUT FUNCTION ON MIO AND EACH SNM AND RIM MODULE) BETWEEN ISOLATORS. 850 DETECTORS IN 4B-C AND MX DETECTORS IN ISOLATOR BASES ARE ISOLATORS.

CONFIDENTIAL: THIS DOCUMENT MUST NOT BE COPIED NOR THE CONTENTS PASSED ON TO ANY THIRD PARTY WITHOUT THE CONSENT OF THE COMPANY.

UNLESS OTHERWISE STATED: ALL DIMENSIONS IN MILLIMETRES. DO NOT SCALE. TOLERANCES ARE TO BE: 1 DECIMAL PLACE ±0.5, 2 DECIMAL PLACES ±0.3, 3 DECIMAL PLACES ±0.1

3rd ANGLE PROJECTION

ISS/REV	AMENDMENTS	ECO	DRN	CHKD	AUTH	APVD	DATE
A	ORIGINAL	-	KJS	RAC	RAC	DSCP	20-8-08
B	NOTE 3 UPDATED.	4167	KJS	LSC	RC	DP	13-8-10
C	4B-I BASE ADDED.	-	KJS	JG	RC	DP	8-8-13

tyco
Fire Protection Products

TYCO FIRE PROTECTION PRODUCTS
17 MARY MULLER DRIVE
P.O. BOX 19545
CHRISTCHURCH, PH: +64 3 3895096
NEW ZEALAND. FAX: +64 3 3895938

MX1			
4B-I / 5B-I ISOLATOR BASE			
WIRING DIAGRAM			
DRAWING No: 1982-71		SHEET 103 of N	
A3	ISS/REV C	PART No:	

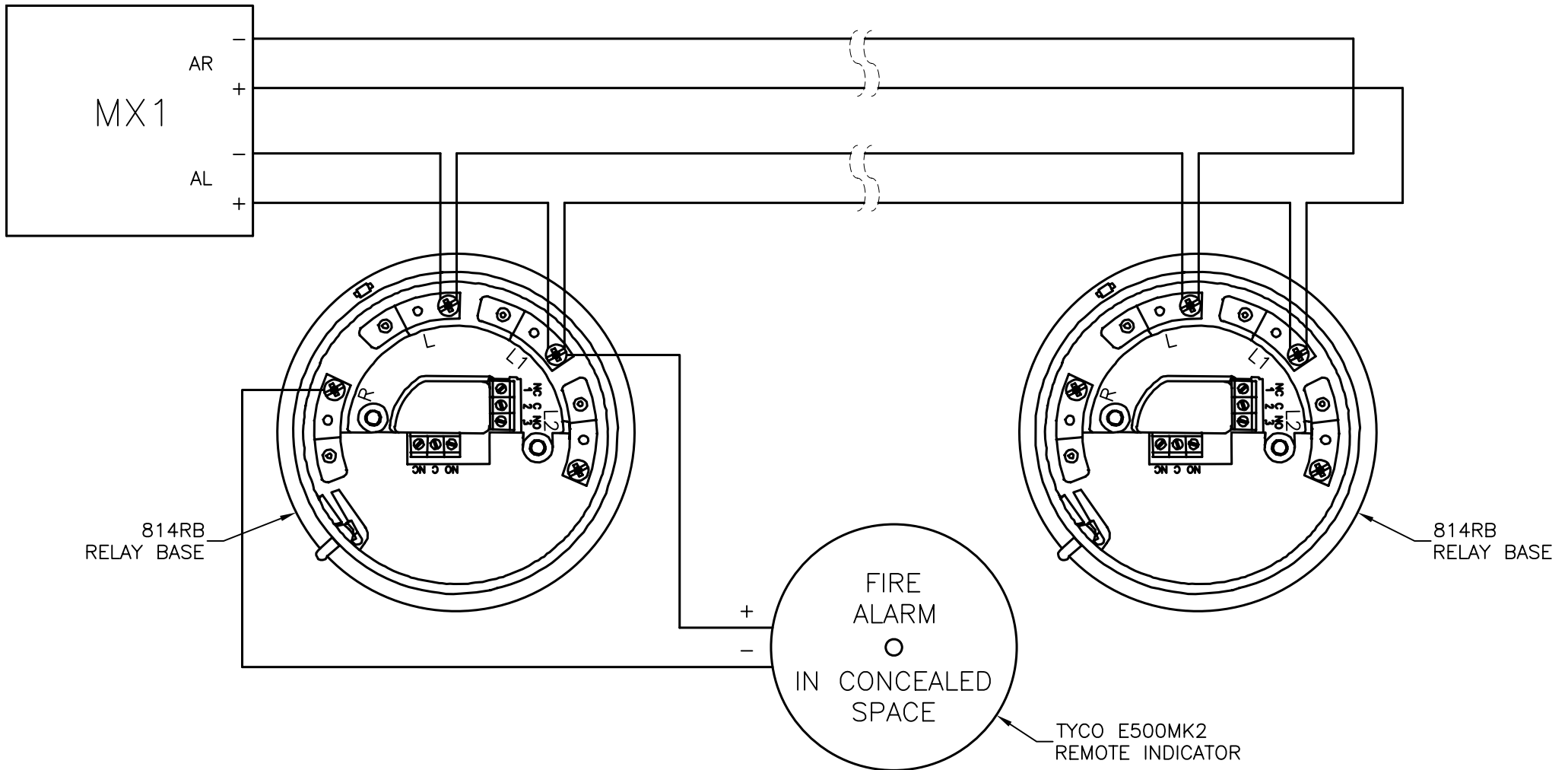

NOTES:

1. RELAY CONTACT RATING 1A @ 30V DC (RESISTIVE.)

CONFIDENTIAL: THIS DOCUMENT MUST NOT BE COPIED NOR THE CONTENTS PASSED ON TO ANY THIRD PARTY WITHOUT THE CONSENT OF THE COMPANY.

UNLESS OTHERWISE STATED: ALL DIMENSIONS IN MILLIMETRES. DO NOT SCALE. TOLERANCES ARE TO BE: 1 DECIMAL PLACE ± 0.5 , 2 DECIMAL PLACES ± 0.3 , 3 DECIMAL PLACES ± 0.1

3rd ANGLE PROJECTION

ISS/REV	AMENDMENTS	ECO	DRN	CHKD	AUTH	APVD	DATE
A	ORIGINAL	-	KJS	RAC	RAC	DSCP	20-6-08

tyco / Safety Products

TYCO SAFETY PRODUCTS
 17 MARY MULLER DRIVE
 P.O. BOX 19545
 CHRISTCHURCH, PH: +64 3 3895096
 NEW ZEALAND. FAX: +64 3 3895938

MX1 814RB RELAY BASE WIRING DIAGRAM			
DRAWING No: 1982-71 SHEET 104 of N			
A3	ISS/REV	A	PART No:

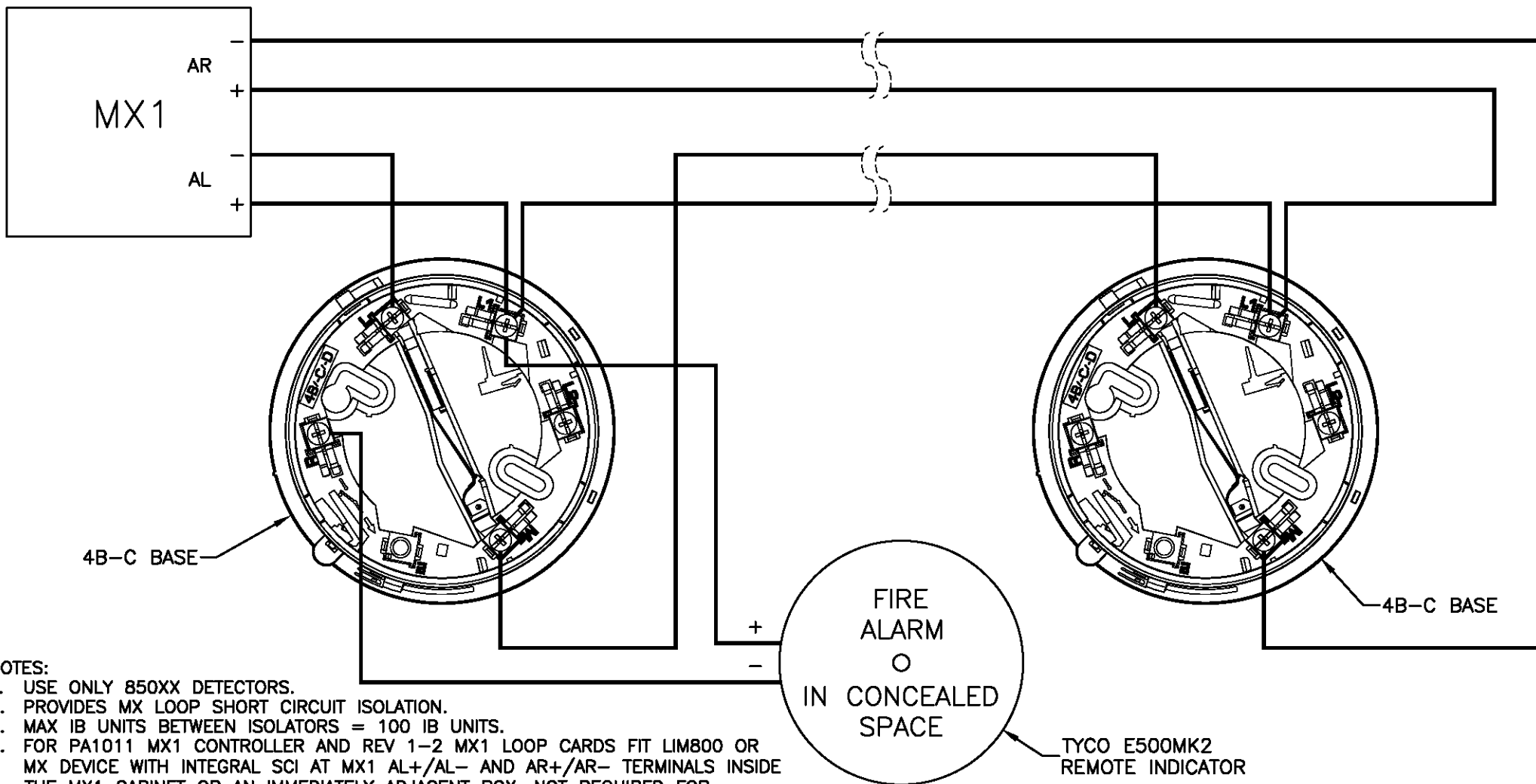

NOTES:

1. USE ONLY 850XX DETECTORS.
2. PROVIDES MX LOOP SHORT CIRCUIT ISOLATION.
3. MAX IB UNITS BETWEEN ISOLATORS = 100 IB UNITS.
4. FOR PA1011 MX1 CONTROLLER AND REV 1-2 MX1 LOOP CARDS FIT LIM800 OR MX DEVICE WITH INTEGRAL SCI AT MX1 AL+/AL- AND AR+/AR- TERMINALS INSIDE THE MX1 CABINET OR AN IMMEDIATELY ADJACENT BOX. NOT REQUIRED FOR PA1081 OR REV 3 ONWARDS LOOP CARDS.
5. NO MORE THAN 40 DEVICES (MX DETECTORS/MODULES + ACTUATING DEVICES ON CIM/DIM/MIM/MIO INPUTS AND EACH SEPARATE OUTPUT FUNCTION ON MIO AND EACH SNM AND RIM MODULE) BETWEEN ISOLATORS. 850 DETECTORS IN 4B-C AND MX DETECTORS IN ISOLATOR BASES ARE ISOLATORS.

CONFIDENTIAL: THIS DOCUMENT MUST NOT BE COPIED NOR THE CONTENTS PASSED ON TO ANY THIRD PARTY WITHOUT THE CONSENT OF THE COMPANY.

UNLESS OTHERWISE STATED: ALL DIMENSIONS IN MILLIMETRES. DO NOT SCALE. TOLERANCES ARE TO BE: 1 DECIMAL PLACE ±0.5, 2 DECIMAL PLACES ±0.3, 3 DECIMAL PLACES ±0.1

3rd ANGLE PROJECTION

ISS/REV	AMENDMENTS	ECO	DRN	CHKD	AUTH	APVD	DATE
A	ORGNAL	-	KJS	JG	RC	DP	6-6-13

tyco
Fire Protection Products
 TYCO FIRE PROTECTION PRODUCTS
 17 MARY MULLER DRIVE
 P.O. BOX 19545
 CHRISTCHURCH, PH: +64 3 3895096
 NEW ZEALAND. FAX: +64 3 3895938

**MX1
 4B-C CONTINUITY BASE
 WIRING DIAGRAM**

DRAWING No: 1982-71 SHEET 105 of N

A3	ISS/REV A	PART No:	
----	-----------	----------	--

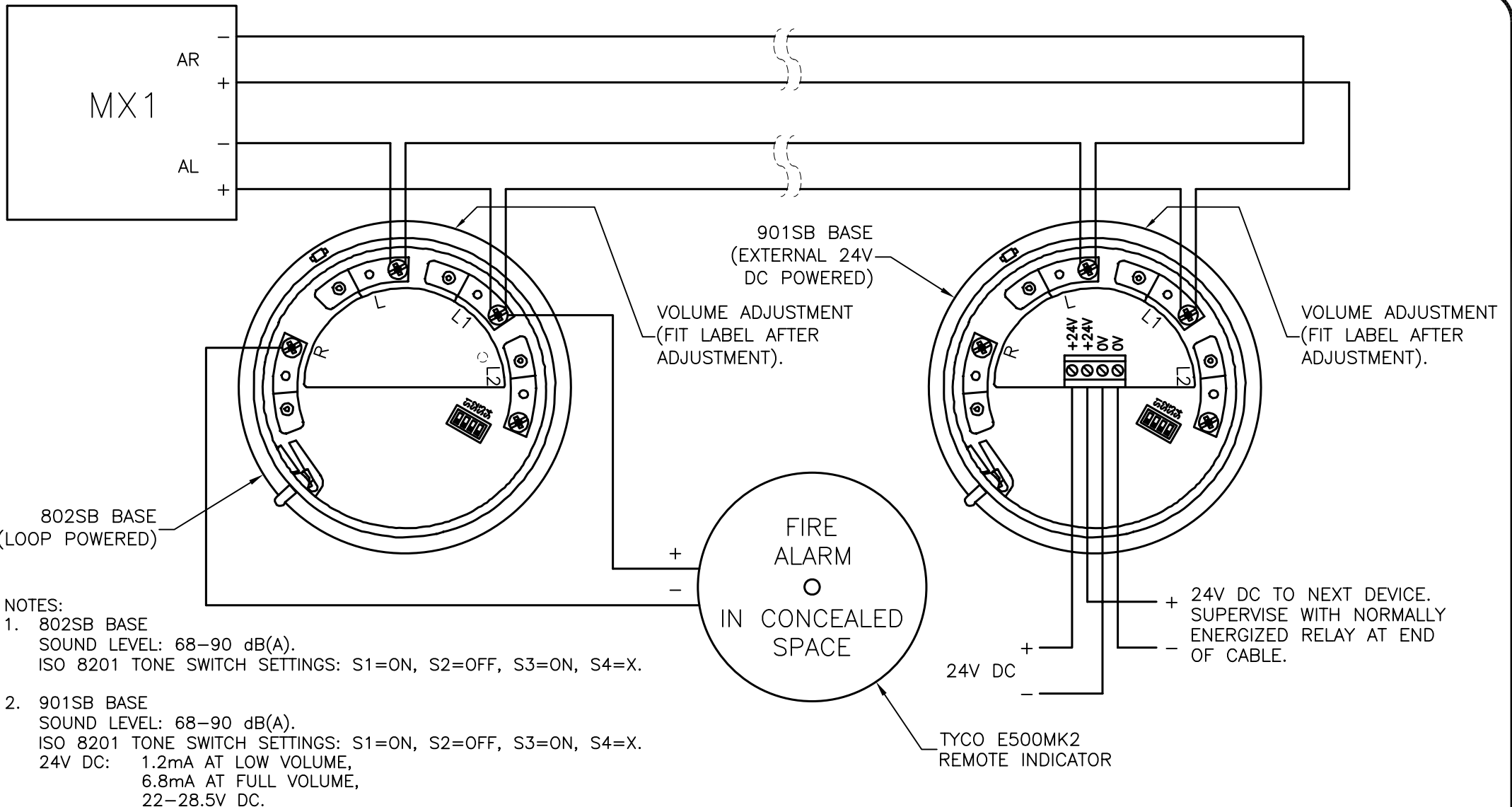

- NOTES:
- 802SB BASE
SOUND LEVEL: 68-90 dB(A).
ISO 8201 TONE SWITCH SETTINGS: S1=ON, S2=OFF, S3=ON, S4=X.
 - 901SB BASE
SOUND LEVEL: 68-90 dB(A).
ISO 8201 TONE SWITCH SETTINGS: S1=ON, S2=OFF, S3=ON, S4=X.
24V DC: 1.2mA AT LOW VOLUME,
6.8mA AT FULL VOLUME,
22-28.5V DC.
 - ADJUST SOUND LEVEL WITH TRIMMER TOOL 517.050.015.

CONFIDENTIAL: THIS DOCUMENT MUST NOT BE COPIED NOR THE CONTENTS PASSED ON TO ANY THIRD PARTY WITHOUT THE CONSENT OF THE COMPANY.

UNLESS OTHERWISE STATED: ALL DIMENSIONS IN MILLIMETRES. DO NOT SCALE. TOLERANCES ARE TO BE: 1 DECIMAL PLACE ±0.5, 2 DECIMAL PLACES ±0.3, 3 DECIMAL PLACES ±0.1

3rd ANGLE PROJECTION

ISS/REV	AMENDMENTS	ECO	DRN	CHKD	AUTH	APVD	DATE
A	ORIGINAL	-	KJS	RAC	RAC	DSCP	23-6-08

tyco / Safety Products

TYCO SAFETY PRODUCTS
17 MARY MULLER DRIVE
P.O. BOX 19545
CHRISTCHURCH, PH: +64 3 3895096
NEW ZEALAND. FAX: +64 3 3895938

MX1
802SB / 901SB SOUNDER BASE
WIRING DIAGRAM

DRAWING No: 1982-71 SHEET 106 of N

A3	ISS/REV	A	PART No:
----	---------	---	----------

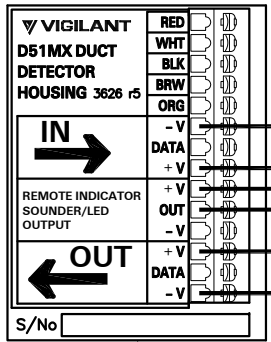
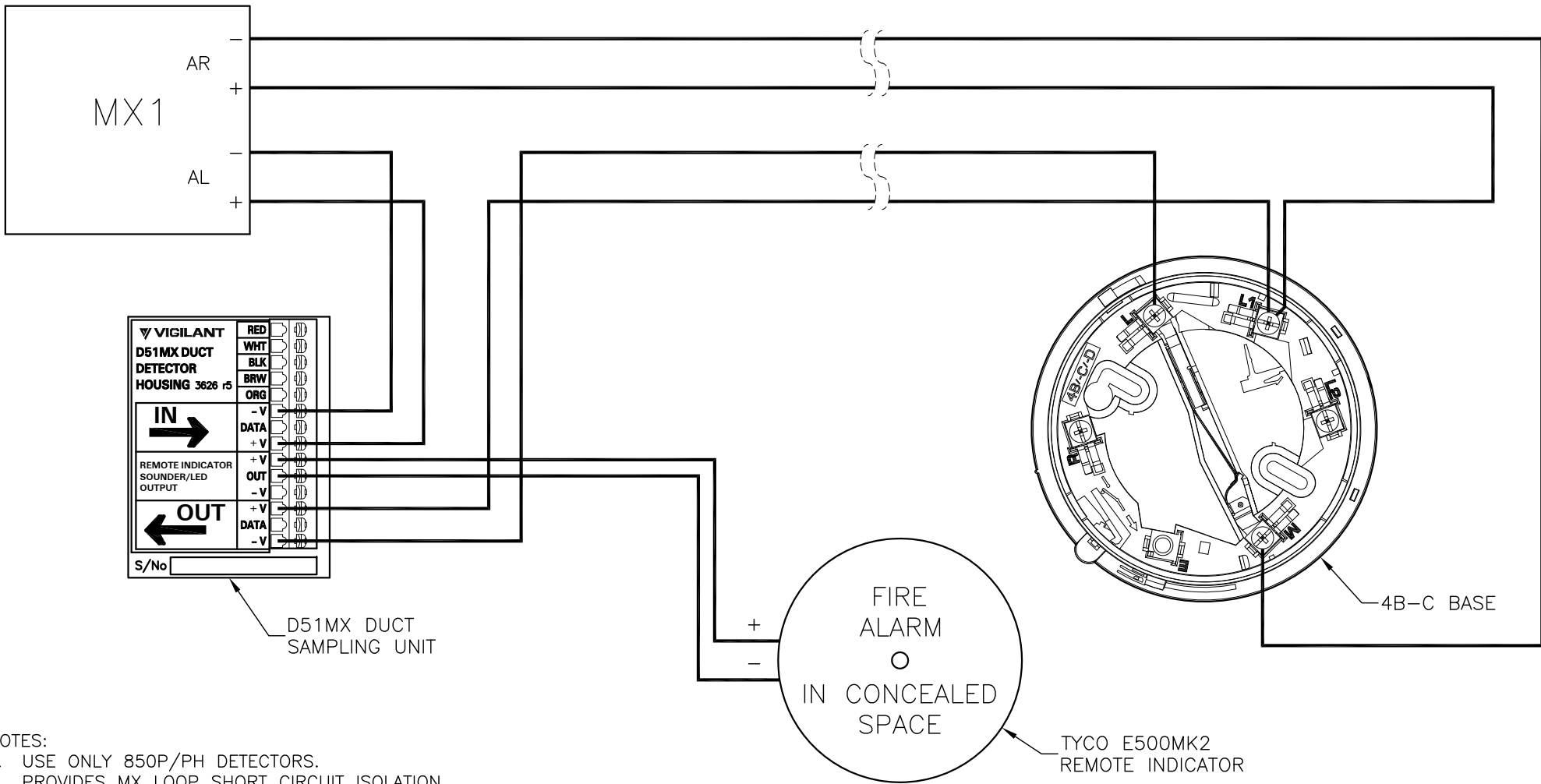

D51MX DUCT SAMPLING UNIT

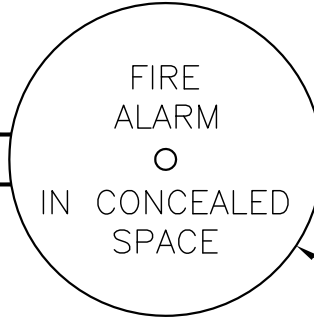

TYCO E500MK2 REMOTE INDICATOR

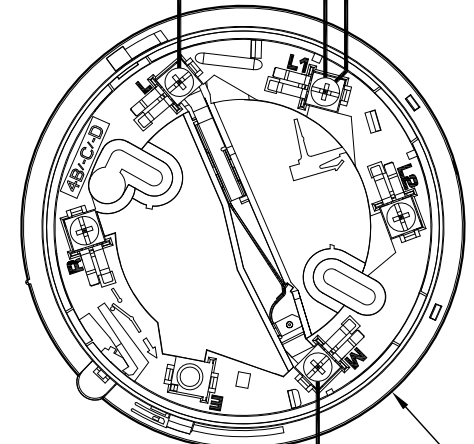

4B-C BASE

- NOTES:
1. USE ONLY 850P/PH DETECTORS.
 2. PROVIDES MX LOOP SHORT CIRCUIT ISOLATION.
 3. MAX IB UNITS BETWEEN ISOLATORS = 100 IB UNITS.
 4. WIRING IS FOR D51MX WITH VIGILANT 3626 R5 OR LATER PCB. REFER TO PBG0202 FOR D51MX WITH TYCO 3626 R4 TERMINATION PCB.

CONFIDENTIAL: THIS DOCUMENT MUST NOT BE COPIED NOR THE CONTENTS PASSED ON TO ANY THIRD PARTY WITHOUT THE CONSENT OF THE COMPANY.

UNLESS OTHERWISE STATED: ALL DIMENSIONS IN MILLIMETRES. DO NOT SCALE. TOLERANCES ARE TO BE: 1 DECIMAL PLACE ±0.5, 2 DECIMAL PLACES ±0.3, 3 DECIMAL PLACES ±0.1

3rd ANGLE PROJECTION

ISS/REV	AMENDMENTS	ECO	DRN	CHKD	AUTH	APVD	DATE
A	ORIGINAL	5031	KJS	JG	RC	DC	6-6-17

tyco
Fire Protection Products
 TYCO FIRE PROTECTION PRODUCTS
 17 MARY MULLER DRIVE
 P.O. BOX 19545
 CHRISTCHURCH, PH: +64 3 3895096
 NEW ZEALAND. FAX: +64 3 3895938

MX1
D51MX DUCT SAMPLING UNIT
WIRING DIAGRAM

DRAWING No: 1982-71 SHEET 168 of N

A3	ISS/REV A	PART No:	
----	-----------	----------	--

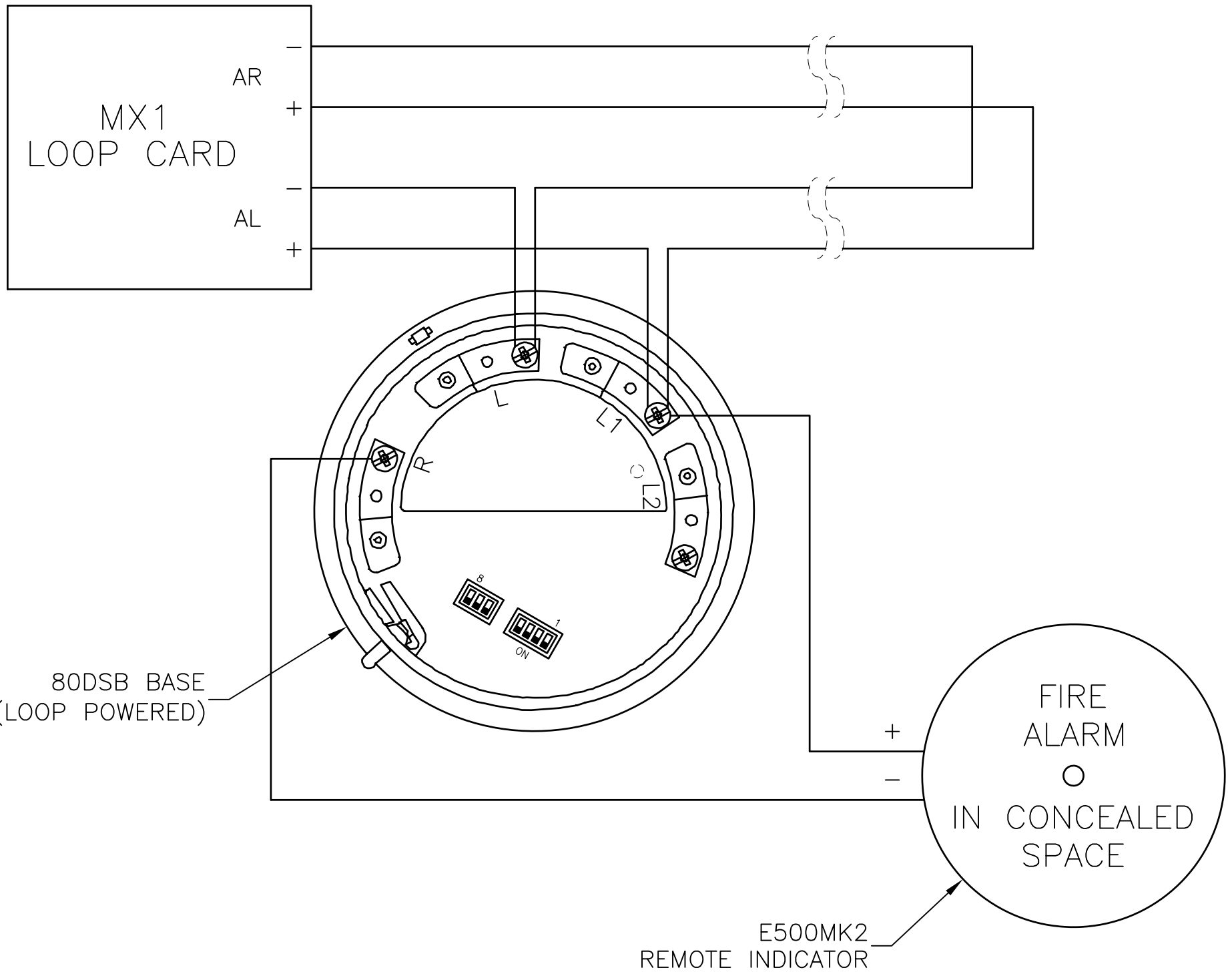

NOTES:
 1. FOR ISO 8201 TONE SWITCH 1 = ON, 2 = OFF, 3 = ON, 4 = OFF.

DIL SWITCH SETTINGS POSITIONS 1-4	TONE
0001	DIN 1 Hz SWEEP
0000	DUTCH SLOW WHOOP
001X	TEMPORAL 4
010X	BS 1 Hz SWEEP
011X	MARCH TIME BEEP
100X	7 Hz FAST SWEEP
101X	TEMPORAL 3
110X	2 TONE
111X	CONTINUOUS 970

2. FOR HIGH VOLUME (90dBA) SWITCH 6 = OFF, 7 = ON, 8 = ON.

DIL SWITCH SETTINGS POSITIONS 6-8	VOLUME	SPL
000	LOW	60dBA
001	MID LOW	70dBA
010	MID HIGH	80dBA
011	HIGH	90dBA

CONFIDENTIAL: THIS DOCUMENT MUST NOT BE COPIED NOR THE CONTENTS PASSED ON TO ANY THIRD PARTY WITHOUT THE CONSENT OF THE COMPANY.

UNLESS OTHERWISE STATED: ALL DIMENSIONS IN MILLIMETRES. DO NOT SCALE. TOLERANCES ARE TO BE: 1 DECIMAL PLACE ±0.5, 2 DECIMAL PLACES ±0.3, 3 DECIMAL PLACES ±0.1

3rd ANGLE PROJECTION

ISS/REV	AMENDMENTS	ECO	DRN	CHKD	AUTH	APVD	DATE
A	ORIGINAL	5276	KJS	RC	MH	DC	20-1-20

© 2019 Johnson Controls. All rights reserved. All specifications and other information shown were current as of document revision date and are subject to change without notice.

JOHNSON CONTROLS
 17 MARY MULLER DRIVE
 P.O. BOX 19545
 CHRISTCHURCH, PH: +64 3 3895096
 NEW ZEALAND. FAX: +64 3 3895938

MX1
80DSB SOUNDER BASE
WIRING DIAGRAM

DRAWING No: **1982-181** SHEET **171** of **N**

A3	ISS/REV A	PART No:
-----------	------------------	----------

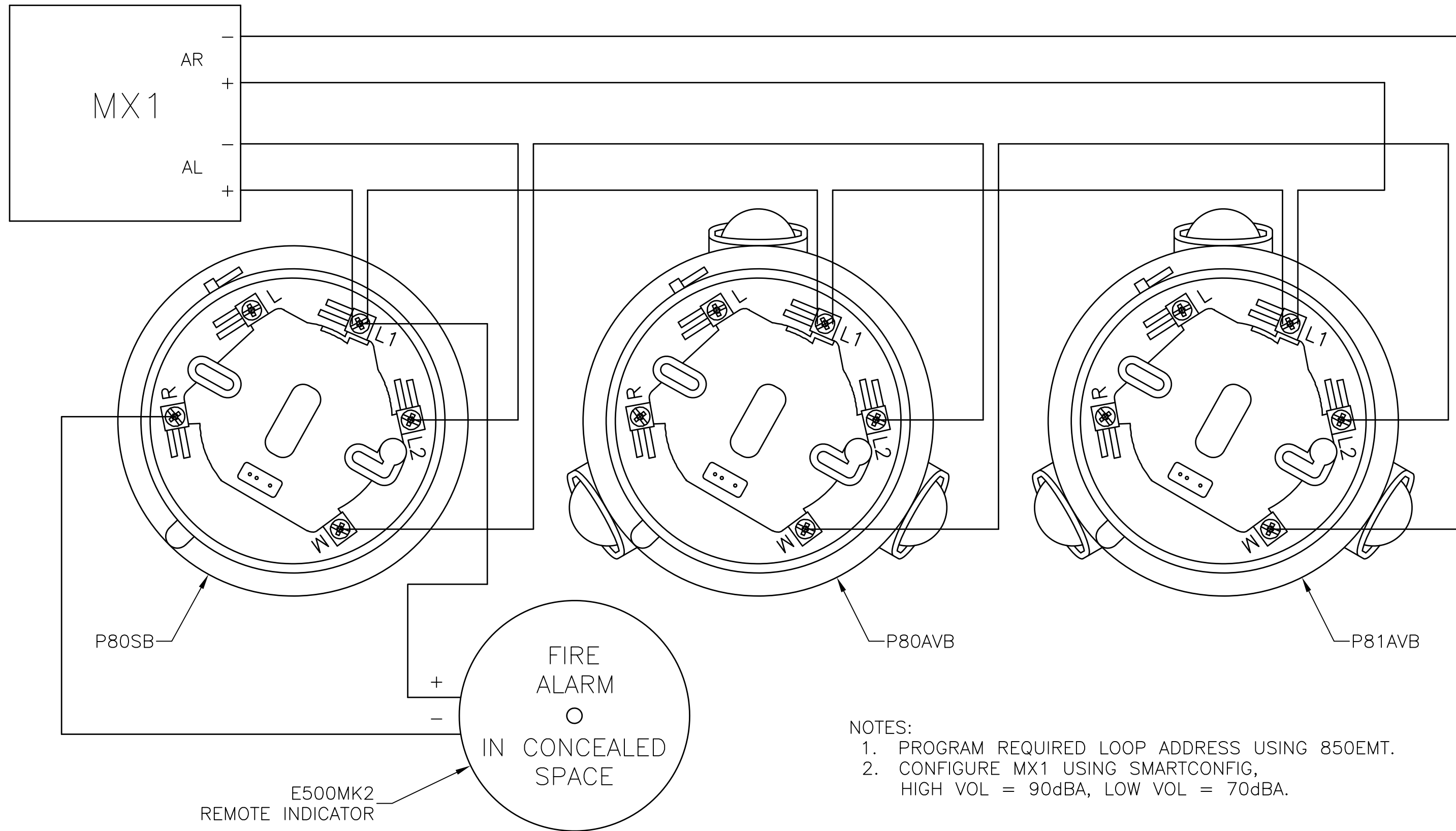

CONFIDENTIAL: THIS DOCUMENT MUST NOT BE COPIED NOR THE CONTENTS PASSED ON TO ANY THIRD PARTY WITHOUT THE CONSENT OF THE COMPANY.

UNLESS OTHERWISE STATED: ALL DIMENSIONS IN MILLIMETRES. DO NOT SCALE. TOLERANCES ARE TO BE: 1 DECIMAL PLACE ±0.5, 2 DECIMAL PLACES ±0.3, 3 DECIMAL PLACES ±0.1

3rd ANGLE PROJECTION

ISS/REV	AMENDMENTS	ECO	DRN	CHKD	AUTH	APVD	DATE
A	ORIGINAL	5276	KJS	RC	MH	DC	21-1-20

© 2020 Johnson Controls. All rights reserved. All specifications and other information shown were current as of document revision date and are subject to change without notice.

JOHNSON CONTROLS
17 MARY MULLER DRIVE
P.O. BOX 19545
CHRISTCHURCH, PH: +64 3 3895096
NEW ZEALAND. FAX: +64 3 3895938

MX1
P80SB / P80AVB / P81AVB MX SOUNDER BASE
WIRING DIAGRAM

DRAWING No: 1982-71 SHEET 172 of N

A3	ISS/REV A	PART No:
----	-----------	----------

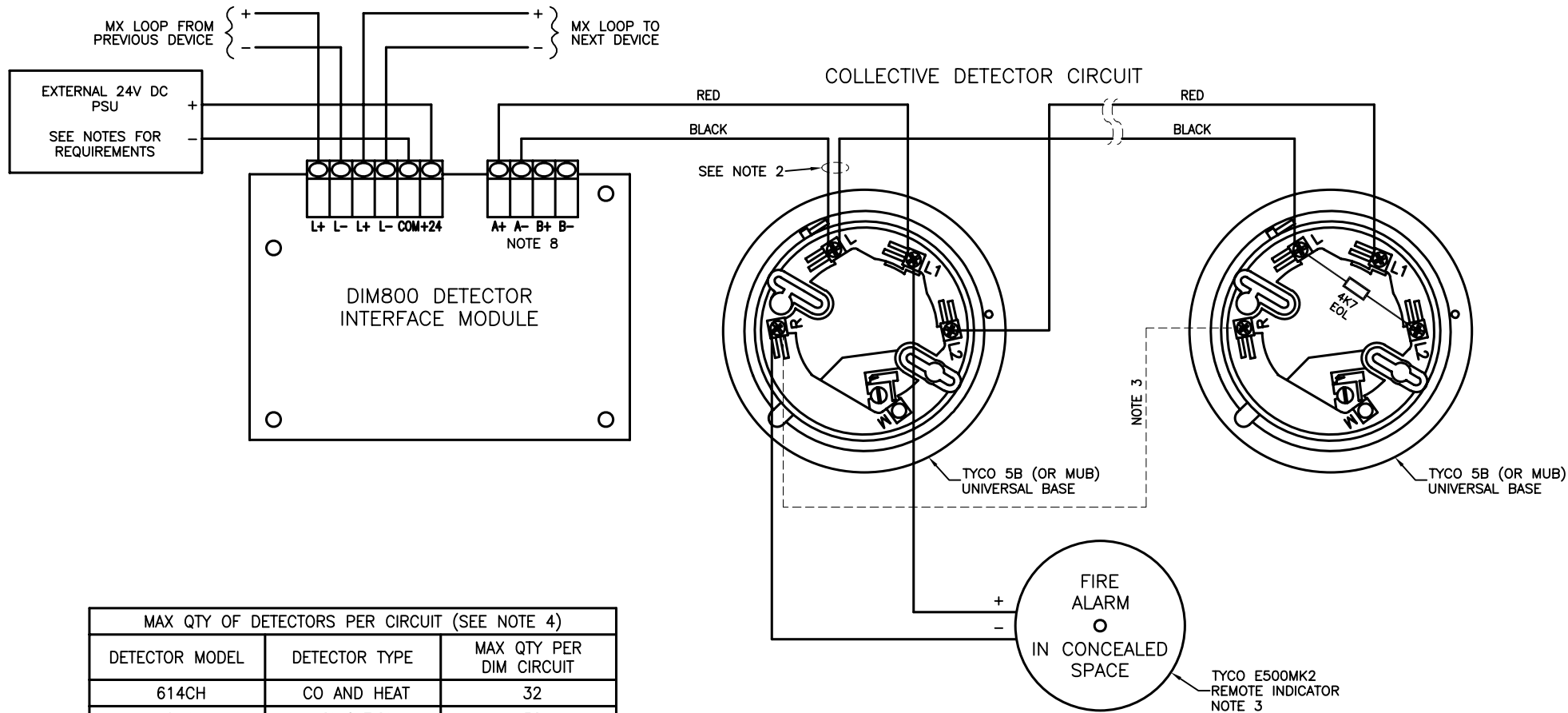

MAX QTY OF DETECTORS PER CIRCUIT (SEE NOTE 4)		
DETECTOR MODEL	DETECTOR TYPE	MAX QTY PER DIM CIRCUIT
614CH	CO AND HEAT	32
614I	IONISATION	38
614P	PHOTOELECTRIC	25
614T	HEAT	23
S/C	HARD CONTACT	40
USED IN 5B OR MUB BASES		

NOTES:

- IF EXTERNAL PSU IS REMOTE, DO NOT CONNECT MORE THAN 40 COLLECTIVE DETECTORS PER CABLE.
- CUT WIRES BEFORE CONNECTING TO TERMINAL L TO MAINTAIN SUPERVISION. DO NOT LOOP WIRE UNDERNEATH TERMINAL L.
- MULTIPLE BASES CAN DRIVE A COMMON REMOTE INDICATOR BY LINKING BASES AS SHOWN.
- WHEN USING MULTIPLE DETECTOR TYPES ON ONE CIRCUIT, THE SUM OF EACH TYPE'S QUANTITY AS A PROPORTION OF ITS MAXIMUM MUST NOT EXCEED 1, E.G. 22 X 614I AND 16 X 614T ARE NOT PERMITTED AS $22/38 + 16/23$ IS GREATER THAN 1.
- MAX DETECTOR CURRENT: 3.0mA PER CIRCUIT.
- EXTERNAL SUPPLY: 20.7-28.7V DC.
CURRENT: 7.5mA + DETECTORS EACH CIRCUIT USED.
ALARM CURRENT: 30-50mA (DEPENDS ON VOLTAGE).
- MAX COLLECTIVE CIRCUIT RESISTANCE: 50 OHMS.
- BOTH Cct A AND B CAN BE USED.

CONFIDENTIAL: THIS DOCUMENT MUST NOT BE COPIED NOR THE CONTENTS PASSED ON TO ANY THIRD PARTY WITHOUT THE CONSENT OF THE COMPANY.

UNLESS OTHERWISE STATED: ALL DIMENSIONS IN MILLIMETRES. DO NOT SCALE. TOLERANCES ARE TO BE: 1 DECIMAL PLACE ±0.5, 2 DECIMAL PLACES ±0.3, 3 DECIMAL PLACES ±0.1

3rd ANGLE PROJECTION

ISS/REV	AMENDMENTS	ECO	DRN	CHKD	AUTH	APVD	DATE
A	ORIGINAL	-	KJS	RAC	RAC	DSCP	20-6-08

tyco / Safety Products

TYCO SAFETY PRODUCTS
17 MARY MULLER DRIVE
P.O. BOX 19545
CHRISTCHURCH, PH: +64 3 3895096
NEW ZEALAND. FAX: +64 3 3895938

MX1
DIM800 DETECTOR INTERFACE MODULE
WIRING DIAGRAM

DRAWING No: 1982-71 SHEET 107 of N

A3	ISS/REV A	PART No:
----	-----------	----------

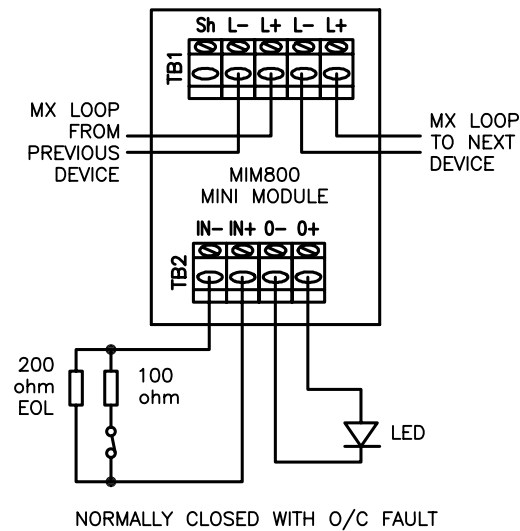
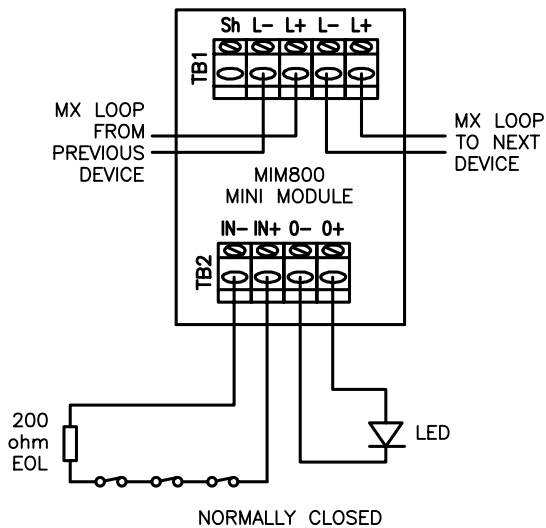
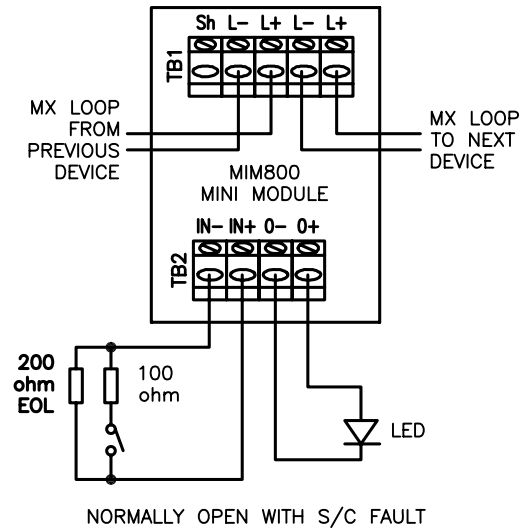
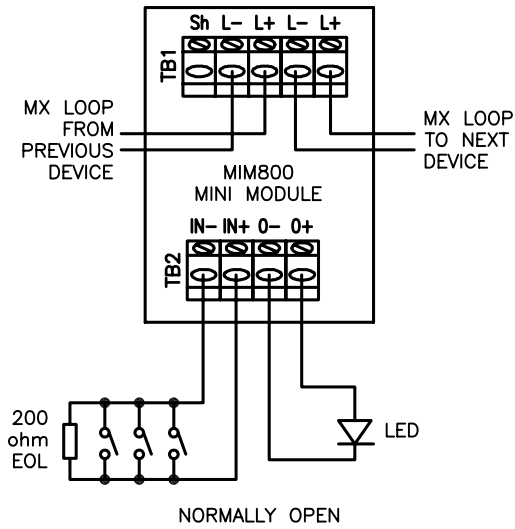

- NOTES:
1. INPUT CONTACTS MUST BE VOLTAGE FREE.
 2. CIRCUIT RESISTANCE: 10 OHM MAX.
 3. CIRCUIT LENGTH: 10m MAX.
 4. LED CURRENT: 2.5mA.
 5. NORMALLY CLOSED MODES DO NOT SUPPORT INTERRUPT.

CONFIDENTIAL: THIS DOCUMENT MUST NOT BE COPIED NOR THE CONTENTS PASSED ON TO ANY THIRD PARTY WITHOUT THE CONSENT OF THE COMPANY.

UNLESS OTHERWISE STATED: ALL DIMENSIONS IN MILLIMETRES. DO NOT SCALE. TOLERANCES ARE TO BE: 1 DECIMAL PLACE ± 0.5 , 2 DECIMAL PLACES ± 0.3 , 3 DECIMAL PLACES ± 0.1

3rd ANGLE PROJECTION

ISS/REV	AMENDMENTS	ECO	DRN	CHKD	AUTH	APVD	DATE
A	ORIGINAL	-	KJS	RAC	RAC	DSCP	25-6-08

tyco / Safety Products

TYCO SAFETY PRODUCTS
17 MARY MULLER DRIVE
P.O. BOX 19545
CHRISTCHURCH, PH: +64 3 3895096
NEW ZEALAND. FAX: +64 3 3895938

MX1
MIM800 MINI INPUT MODULE
WIRING DIAGRAM

DRAWING No: 1982-71 SHEET 108 of N

A3 ISS/REV A PART No:

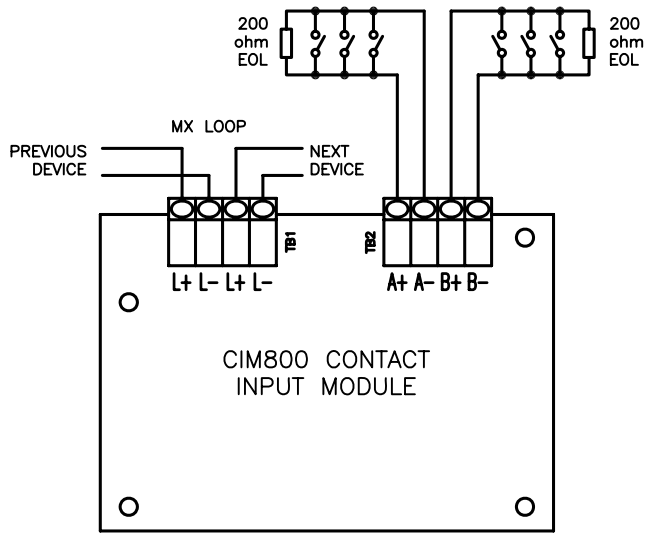

NORMALLY OPEN

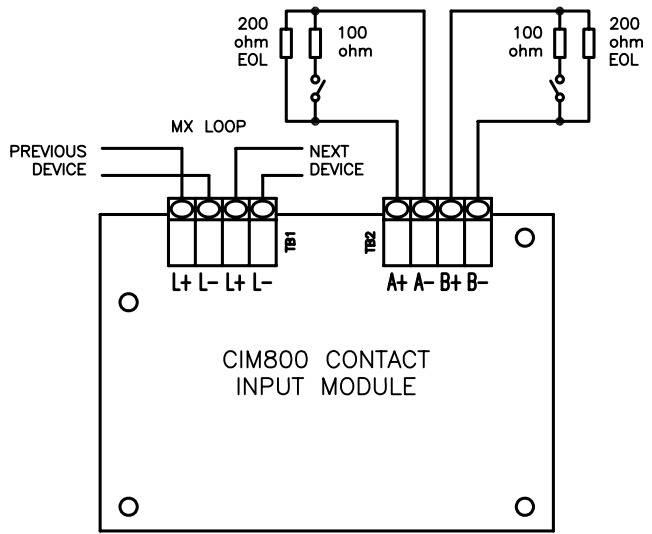

NORMALLY OPEN, S/C = FAULT

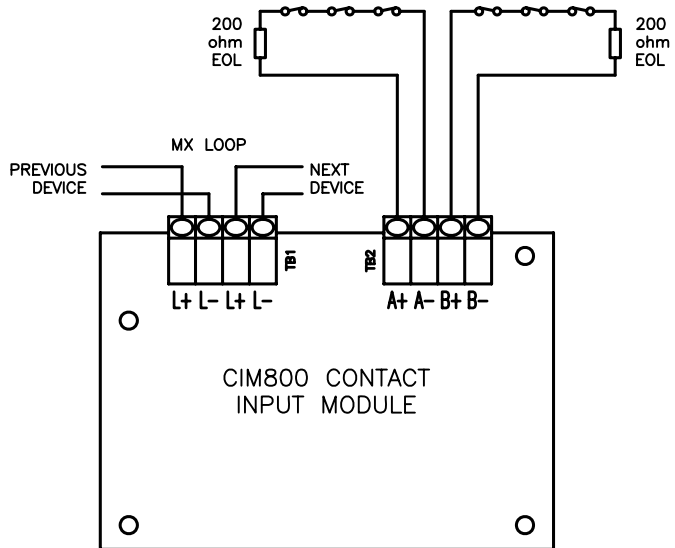

NORMALLY CLOSED

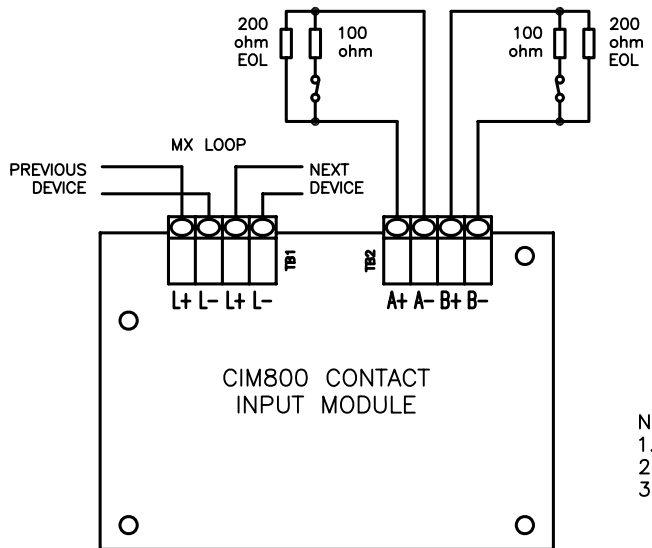

NORMALLY CLOSED, O/C = FAULT

- NOTES:
1. INPUT CONTACTS MUST BE VOLTAGE FREE.
 2. CIRCUIT RESISTANCE: 10 OHM MAX.
 3. CIRCUITS MUST NOT BE JOINED TOGETHER OR TO ANY OTHER WIRING.

CONFIDENTIAL: THIS DOCUMENT MUST NOT BE COPIED NOR THE CONTENTS PASSED ON TO ANY THIRD PARTY WITHOUT THE CONSENT OF THE COMPANY.

UNLESS OTHERWISE STATED: ALL DIMENSIONS IN MILLIMETRES. DO NOT SCALE. TOLERANCES ARE TO BE: 1 DECIMAL PLACE ±0.5, 2 DECIMAL PLACES ±0.3, 3 DECIMAL PLACES ±0.1

3rd ANGLE PROJECTION

ISS/REV	AMENDMENTS	ECO	DRN	CHKD	AUTH	APVD	DATE
A	ORIGINAL	-	KJS	RAC	RAC	DSCP	25-6-08

tyco / Safety Products

TYCO SAFETY PRODUCTS
 17 MARY MULLER DRIVE
 P.O. BOX 19545
 CHRISTCHURCH, PH: +64 3 3895096
 NEW ZEALAND. FAX: +64 3 3895938

MX1
CIM800 CONTACT INPUT MODULE
WIRING DIAGRAM

DRAWING No: 1982-71 **SHEET** 109 of N

A3	ISS/REV	A	PART No:
----	---------	---	----------

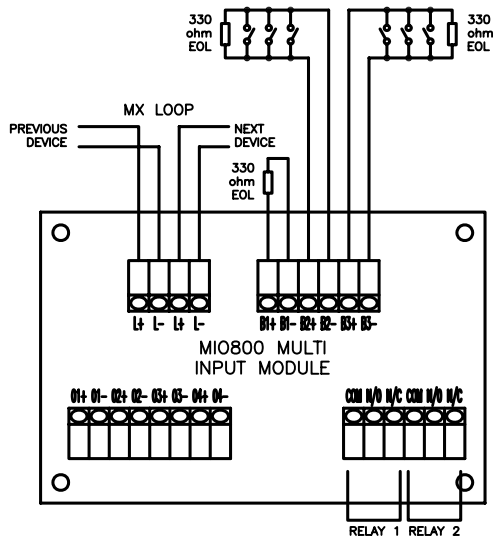

NORMALLY OPEN
S/C = ALARM, O/C = FAULT

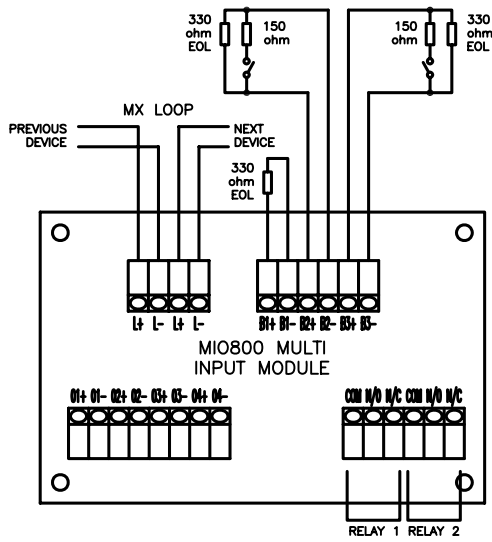

NORMALLY OPEN
S/C = FAULT, O/C = FAULT

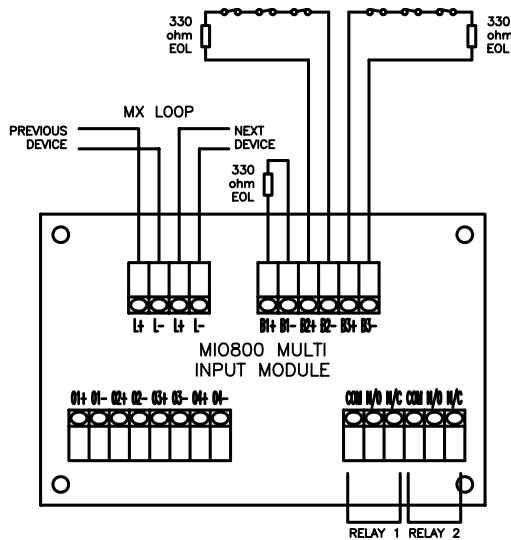

NORMALLY CLOSED
S/C = FAULT, O/C = ALARM

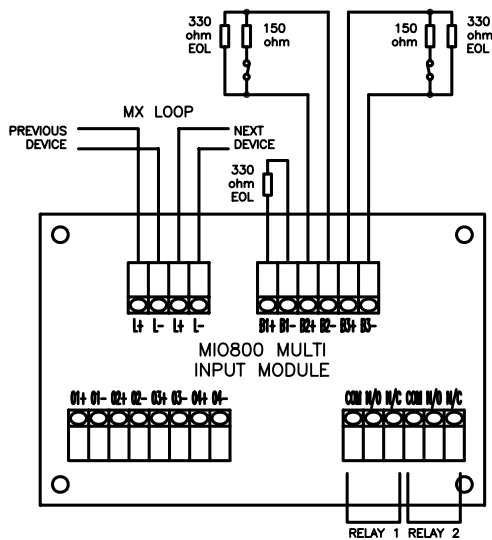

NORMALLY CLOSED
O/C = FAULT, S/C = FAULT

NOTES:

1. INPUT CONTACTS MUST BE VOLTAGE FREE.
2. CIRCUIT RESISTANCE: 40 OHM MAX.
3. RELAYS ARE SINGLE POLE, UNSUPERVISED, VOLTAGE FREE CHANGE-OVER. CONTACT RATING: 2A @ 24V DC (RESISTIVE).
4. INPUT 1 CAN BE WIRED AS PER INPUTS 2 OR 3 AS SHOWN.
5. ONLY INPUTS 1 AND 2 SUPPORT INTERRUPT.
6. DO NOT USE 01 TO 04 OUTPUTS.
7. CIRCUITS MUST NOT BE JOINED TOGETHER OR TO ANY OTHER WIRING.
8. FOR VIO800 WIRING REFER TO SHEET 119.

CONFIDENTIAL: THIS DOCUMENT MUST NOT BE COPIED NOR THE CONTENTS PASSED ON TO ANY THIRD PARTY WITHOUT THE CONSENT OF THE COMPANY.

UNLESS OTHERWISE STATED: ALL DIMENSIONS IN MILLIMETRES. DO NOT SCALE. TOLERANCES ARE TO BE: 1 DECIMAL PLACE ±0.5, 2 DECIMAL PLACES ±0.3, 3 DECIMAL PLACES ±0.1

3rd ANGLE PROJECTION

ISS/REV	AMENDMENTS	ECO	DRN	CHKD	AUTH	APVD	DATE
A	ORIGINAL	-	KJS	RAC	RAC	DSCP	25-6-08

tyco / Safety Products
 TYCO SAFETY PRODUCTS
 17 MARY MULLER DRIVE
 P.O. BOX 19545
 CHRISTCHURCH, PH: +64 3 3895096
 NEW ZEALAND. FAX: +64 3 3895938

MX1
MIO800 MULTI INPUT MODULE
WIRING DIAGRAM

DRAWING No: 1982-71 SHEET 110 of N

A3	ISS/REV A	PART No:
----	-----------	----------

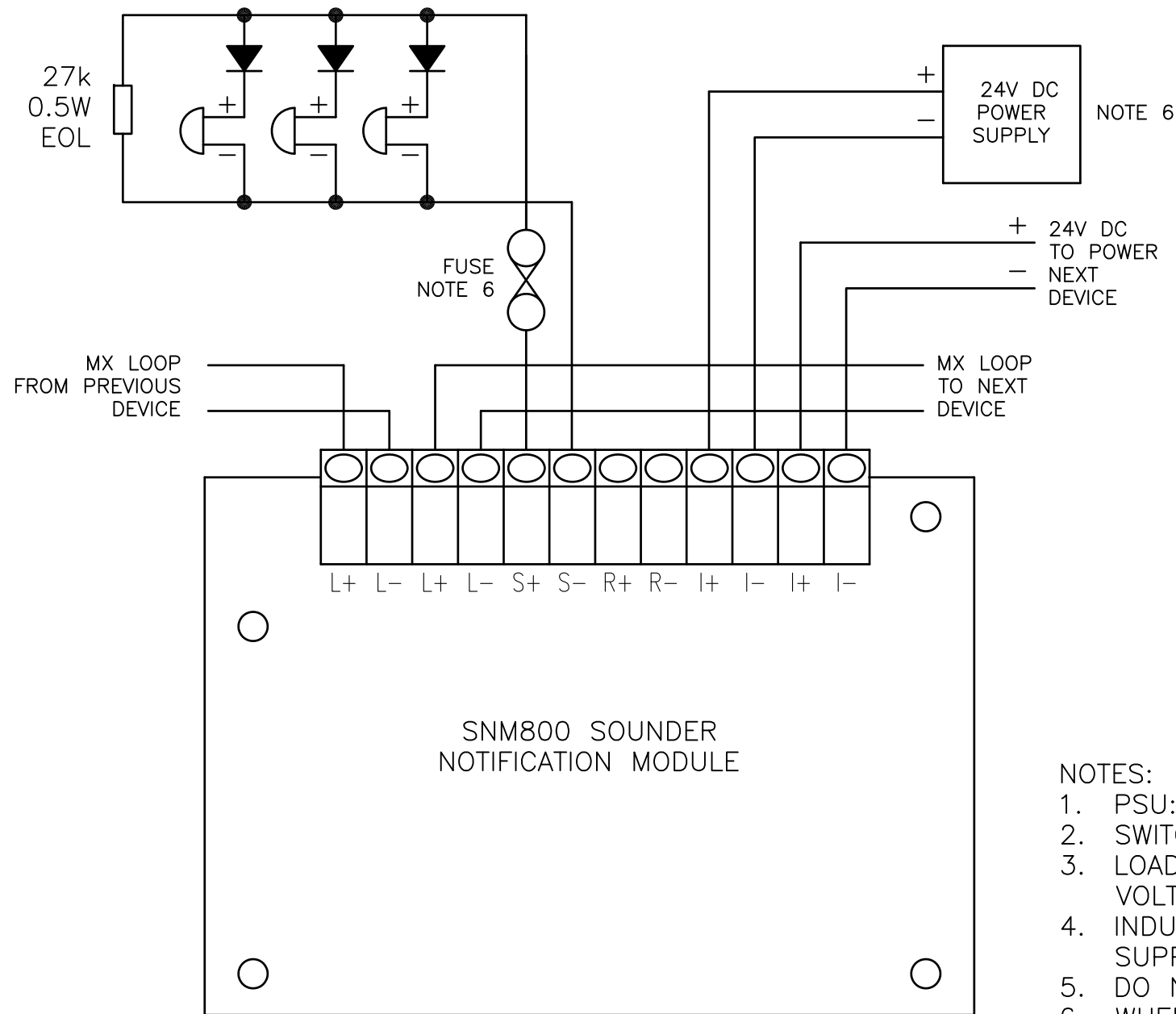

NOTES:

1. PSU: 20-30V DC.
2. SWITCHED OUTPUT: PSU VOLTAGE; 2A MAX. ELD: 27k.
3. LOAD DEVICES MUST HAVE SERIES DIODE AND BE VOLTAGE FREE.
4. INDUCTIVE LOADS MUST HAVE BACK-EMF DIODE OR SUPPRESSION.
5. DO NOT USE R+, R- TERMINAL.
6. WHERE A COMMON SUPPLY IS USED FOR MULTIPLE OUTPUTS (E.G. FLOOR/AREAS OF ALARM DEVICES) EACH OUTPUT NEEDS TO BE FUSED, WITH A RATING JUST GREATER THAN THE MAXIMUM LOAD CURRENT. FIT FUSE TO SNM800.

CONFIDENTIAL: THIS DOCUMENT MUST NOT BE COPIED NOR THE CONTENTS PASSED ON TO ANY THIRD PARTY WITHOUT THE CONSENT OF THE COMPANY.

UNLESS OTHERWISE STATED: ALL DIMENSIONS IN MILLIMETRES. DO NOT SCALE. TOLERANCES ARE TO BE: 1 DECIMAL PLACE ±0.5, 2 DECIMAL PLACES ±0.3, 3 DECIMAL PLACES ±0.1

3rd ANGLE PROJECTION

ISS/REV	AMENDMENTS	ECO	DRN	CHKD	AUTH	APVD	DATE
A	ORIGINAL	-	KJS	RAC	RAC	DSCP	25-6-08
B	NOTE 6 & FUSE ADDED.	5276	KJS	RC	MH	DC	20-1-20

© 2019 Johnson Controls. All rights reserved. All specifications and other information shown were current as of document revision date and are subject to change without notice.

JOHNSON CONTROLS
 17 MARY MULLER DRIVE
 P.O. BOX 19545
 CHRISTCHURCH, PH: +64 3 3895096
 NEW ZEALAND. FAX: +64 3 3895938

MX1
SNM800 SOUNDER NOTIFICATION MODULE
WIRING DIAGRAM

DRAWING No: **1982-71** SHEET **111** of **N**

A3	ISS/REV B	PART No:	
-----------	------------------	----------	--

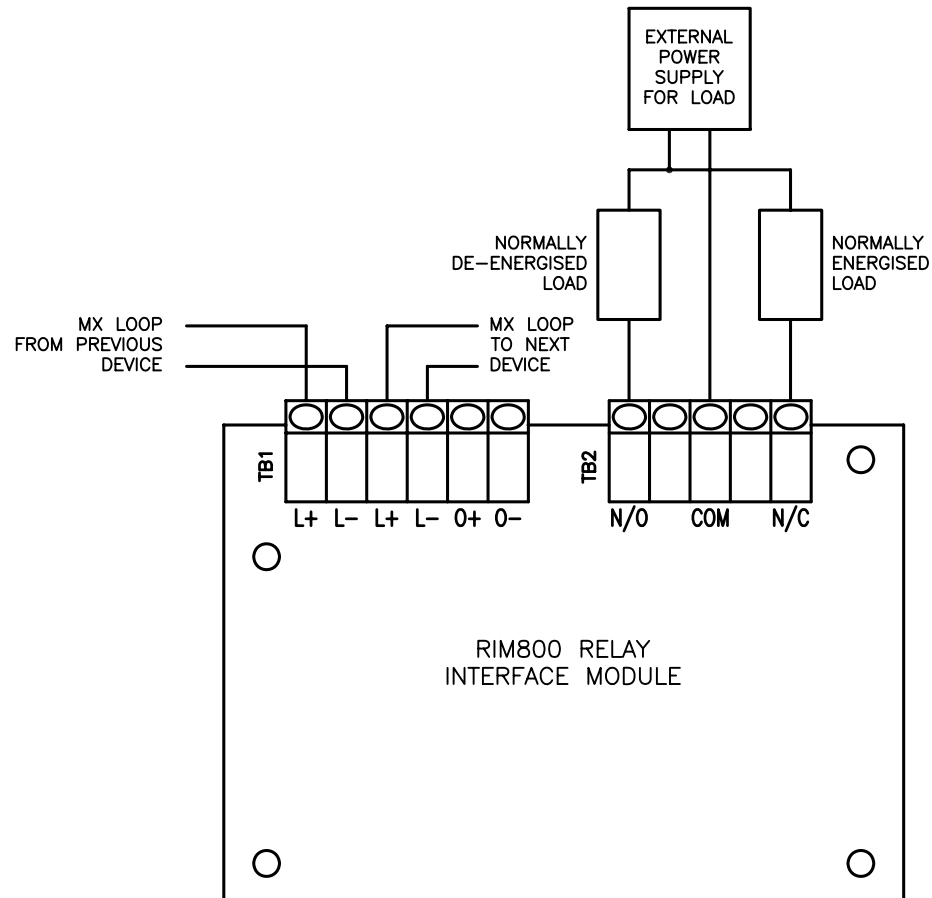

NOTES:

1. RELAY IS SINGLE POLE CHANGEOVER, UNSUPERVISED, VOLTAGE-FREE OUTPUT.
2. CONTACT RATING: 2A @ 30V DC (RESISTIVE).
3. LEAVE 0+ AND 0- TERMINALS UNCONNECTED

CONFIDENTIAL: THIS DOCUMENT MUST NOT BE COPIED NOR THE CONTENTS PASSED ON TO ANY THIRD PARTY WITHOUT THE CONSENT OF THE COMPANY.

UNLESS OTHERWISE STATED: ALL DIMENSIONS IN MILLIMETRES. DO NOT SCALE. TOLERANCES ARE TO BE: 1 DECIMAL PLACE ± 0.5 , 2 DECIMAL PLACES ± 0.3 , 3 DECIMAL PLACES ± 0.1

3rd ANGLE PROJECTION

ISS/REV	AMENDMENTS	ECO	DRN	CHKD	AUTH	APVD	DATE
A	ORIGINAL	-	KJS	RAC	RAC	DSCP	25-6-08

tyco / Safety Products

TYCO SAFETY PRODUCTS
 17 MARY MULLER DRIVE
 P.O. BOX 19545
 CHRISTCHURCH, PH: +64 3 3895096
 NEW ZEALAND. FAX: +64 3 3895938

MX1 RIM800 RELAY INTERFACE MODULE WIRING DIAGRAM			
DRAWING No: 1982-71		SHEET 112 of N	
A3	ISS/REV A	PART No:	

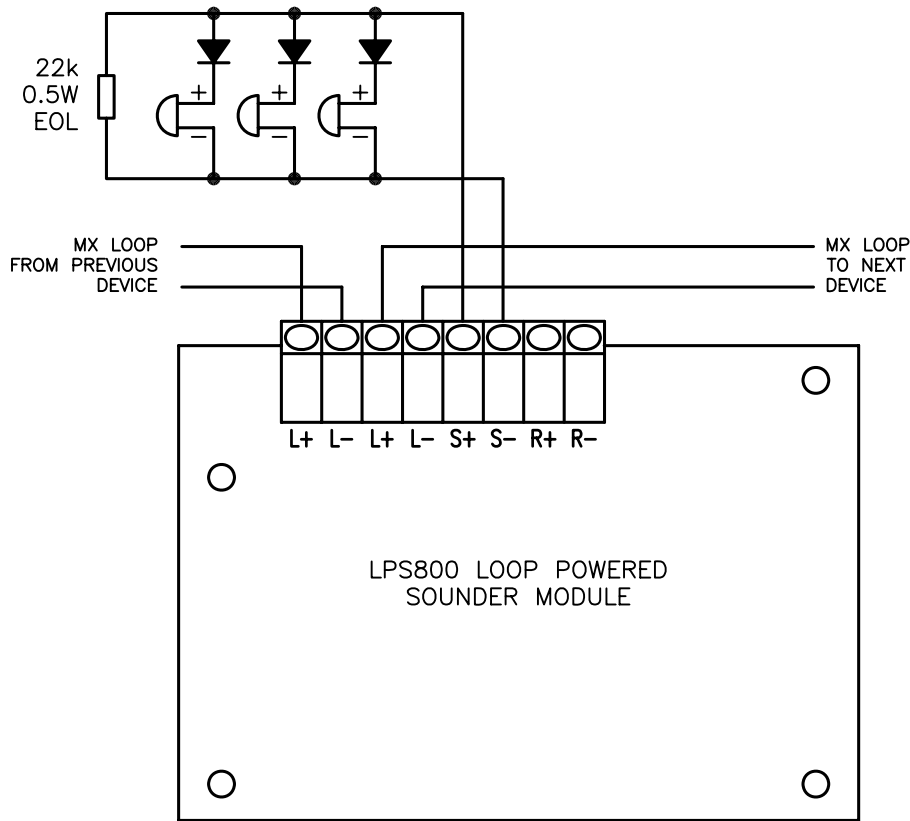

SPUR WIRING (CLASS B)

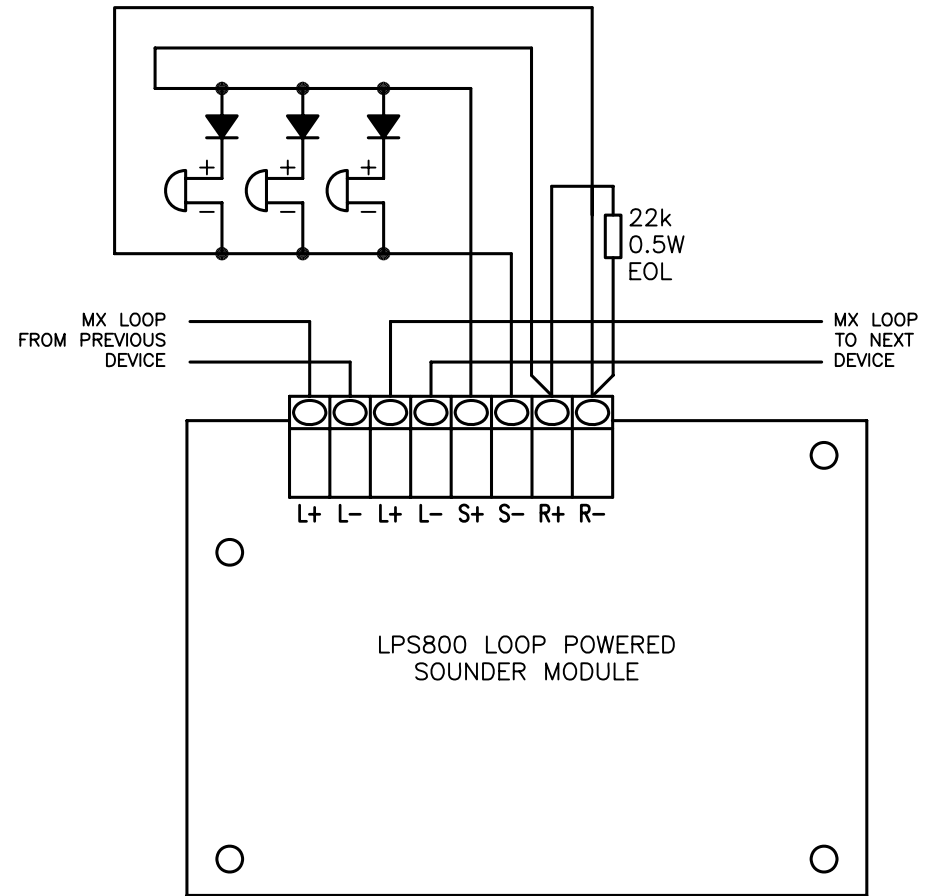

LOOP WIRING (CLASS A)

NOTES:

1. S+ S- OUTPUT: 75mA @ 24V DC MAX.
2. OUTPUT VOLTAGE = MX LOOP-2V, WHEN MX LOOP <26V.
3. LOAD DEVICES MUST HAVE SERIES DIODE AND BE VOLTAGE FREE.
4. INDUCTIVE LOADS MUST HAVE BACK-EMF DIODE OR SUPPRESSION.

CONFIDENTIAL: THIS DOCUMENT MUST NOT BE COPIED NOR THE CONTENTS PASSED ON TO ANY THIRD PARTY WITHOUT THE CONSENT OF THE COMPANY.

UNLESS OTHERWISE STATED: ALL DIMENSIONS IN MILLIMETRES. DO NOT SCALE. TOLERANCES ARE TO BE: 1 DECIMAL PLACE ±0.5, 2 DECIMAL PLACES ±0.3, 3 DECIMAL PLACES ±0.1

3rd ANGLE PROJECTION

ISS/REV	AMENDMENTS	ECO	DRN	CHKD	AUTH	APVD	DATE
A	ORIGINAL	-	KJS	RAC	RAC	DSCP	25-6-08

tyco / Safety Products

TYCO SAFETY PRODUCTS
 17 MARY MULLER DRIVE
 P.O. BOX 19545
 CHRISTCHURCH, PH: +64 3 3895096
 NEW ZEALAND. FAX: +64 3 3895938

MX1
LPS800 LOOP POWERED SOUNDER MODULE
WIRING DIAGRAM

DRAWING No: 1982-71 SHEET 113 of N

A3	ISS/REV A	PART No:	
----	-----------	----------	--

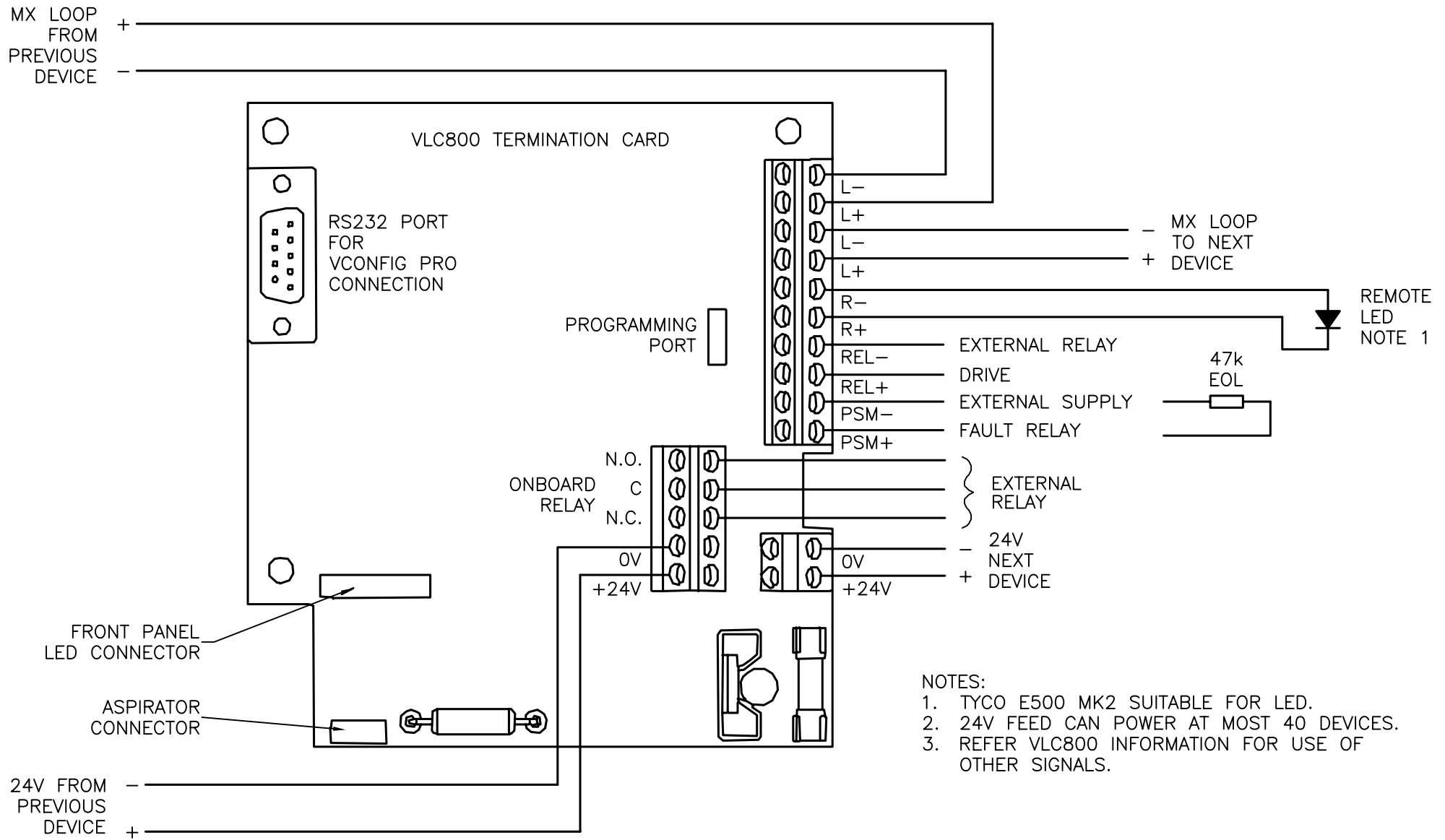

- NOTES:
1. TYCO E500 MK2 SUITABLE FOR LED.
 2. 24V FEED CAN POWER AT MOST 40 DEVICES.
 3. REFER VLC800 INFORMATION FOR USE OF OTHER SIGNALS.

CONFIDENTIAL: THIS DOCUMENT MUST NOT BE COPIED NOR THE CONTENTS PASSED ON TO ANY THIRD PARTY WITHOUT THE CONSENT OF THE COMPANY.

UNLESS OTHERWISE STATED: ALL DIMENSIONS IN MILLIMETRES. DO NOT SCALE. TOLERANCES ARE TO BE: 1 DECIMAL PLACE ±0.5, 2 DECIMAL PLACES ±0.3, 3 DECIMAL PLACES ±0.1

3rd ANGLE PROJECTION

ISS/REV	AMENDMENTS	ECO	DRN	CHKD	AUTH	APVD	DATE
A	ORIGINAL	-	KJS	RAC	RAC	DSCP	8-08-08

tyco / Safety Products

TYCO SAFETY PRODUCTS
 17 MARY MULLER DRIVE
 P.O. BOX 19545
 CHRISTCHURCH, PH: +64 3 3895096
 NEW ZEALAND. FAX: +64 3 3895938

**MX1
 VLC800MX
 WIRING DIAGRAM**

DRAWING No: 1982-71 SHEET 114 of N

A3	ISS/REV A	PART No:	
----	-----------	----------	--

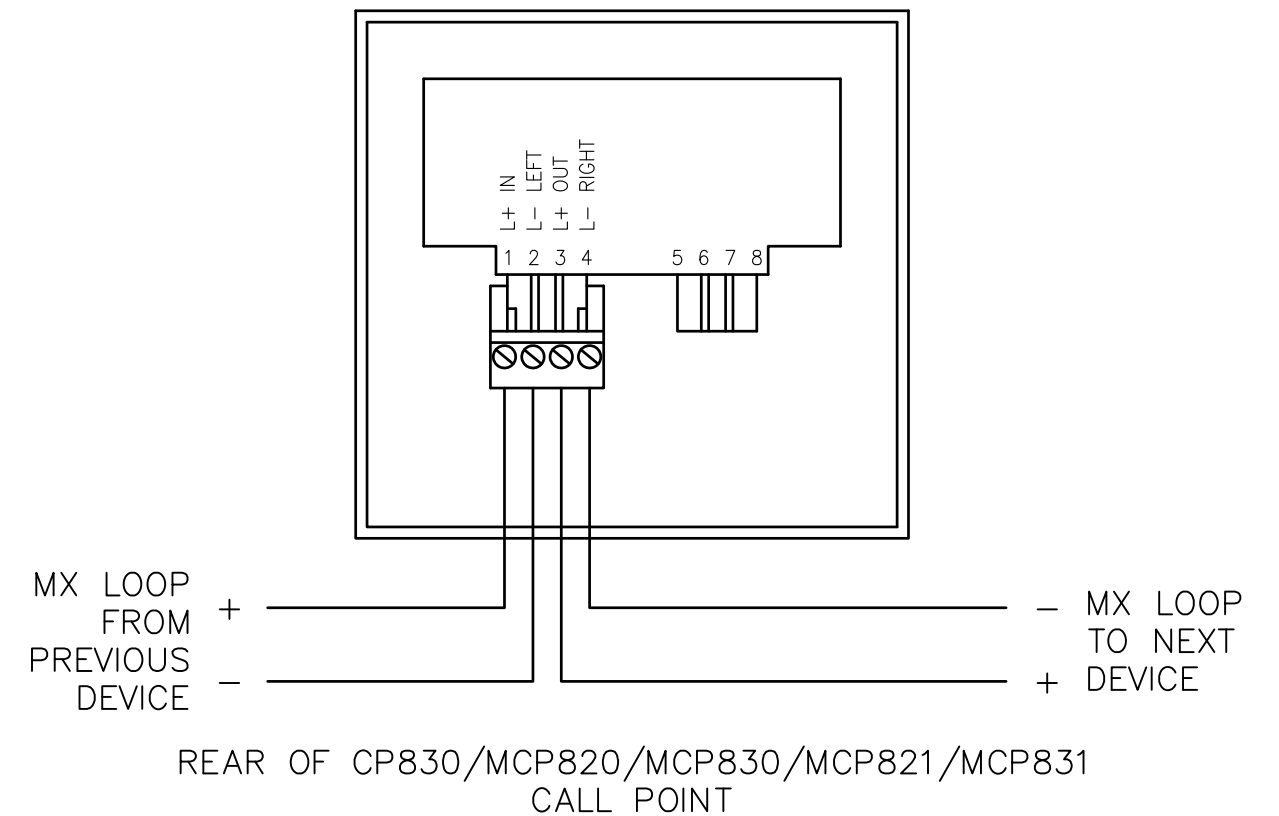
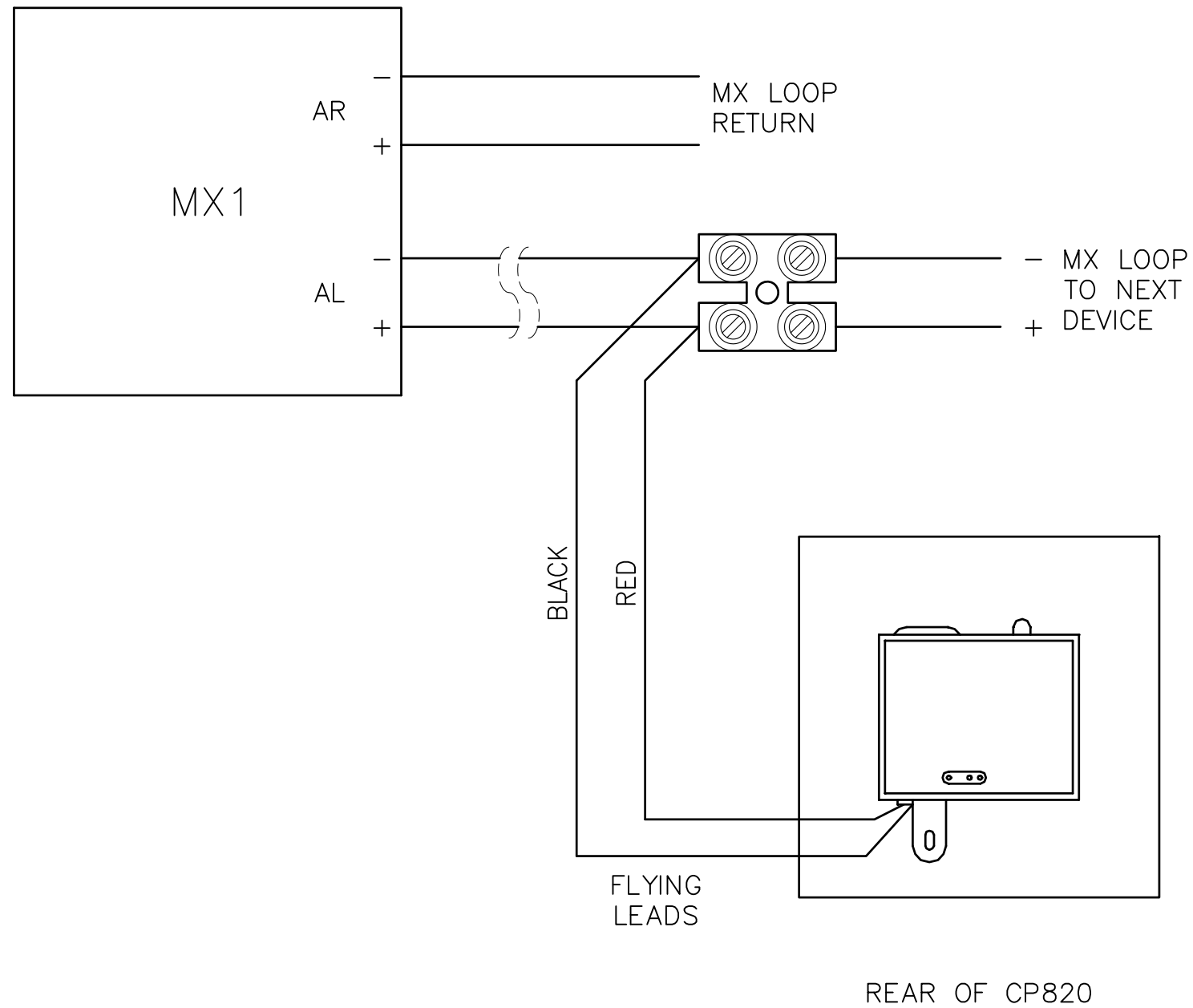

CONFIDENTIAL: THIS DOCUMENT MUST NOT BE COPIED NOR THE CONTENTS PASSED ON TO ANY THIRD PARTY WITHOUT THE CONSENT OF THE COMPANY.

UNLESS OTHERWISE STATED: ALL DIMENSIONS IN MILLIMETRES. DO NOT SCALE. TOLERANCES ARE TO BE: 1 DECIMAL PLACE ± 0.5 , 2 DECIMAL PLACES ± 0.3 , 3 DECIMAL PLACES ± 0.1

3rd ANGLE PROJECTION

ISS/REV	AMENDMENTS	ECO	DRN	CHKD	AUTH	APVD	DATE
A	ORIGINAL	-	KJS	RAC	RAC	DSCP	25-6-08
B	CP830, MCP820/830 DETAILS ADDED.	5053	KJS	RC	RC	DC	9-8-17
C	MCP821/MCP831 DETAILS ADDED.	5276	KJS	RC	MH	DC	20-1-20

© 2017 Johnson Controls. All rights reserved.
All specifications and other information shown were current as of document revision date and are subject to change without notice.

JOHNSON CONTROLS
17 MARY MULLER DRIVE
P.O. BOX 19545
CHRISTCHURCH, PH: +64 3 3895096
NEW ZEALAND. FAX: +64 3 3895938

MX1
CP820/30 / MCP820/30 / MCP821/31 MCP
WIRING DIAGRAM

DRAWING No: 1982-71 SHEET 115 of N

A3 ISS/REV C PART No:

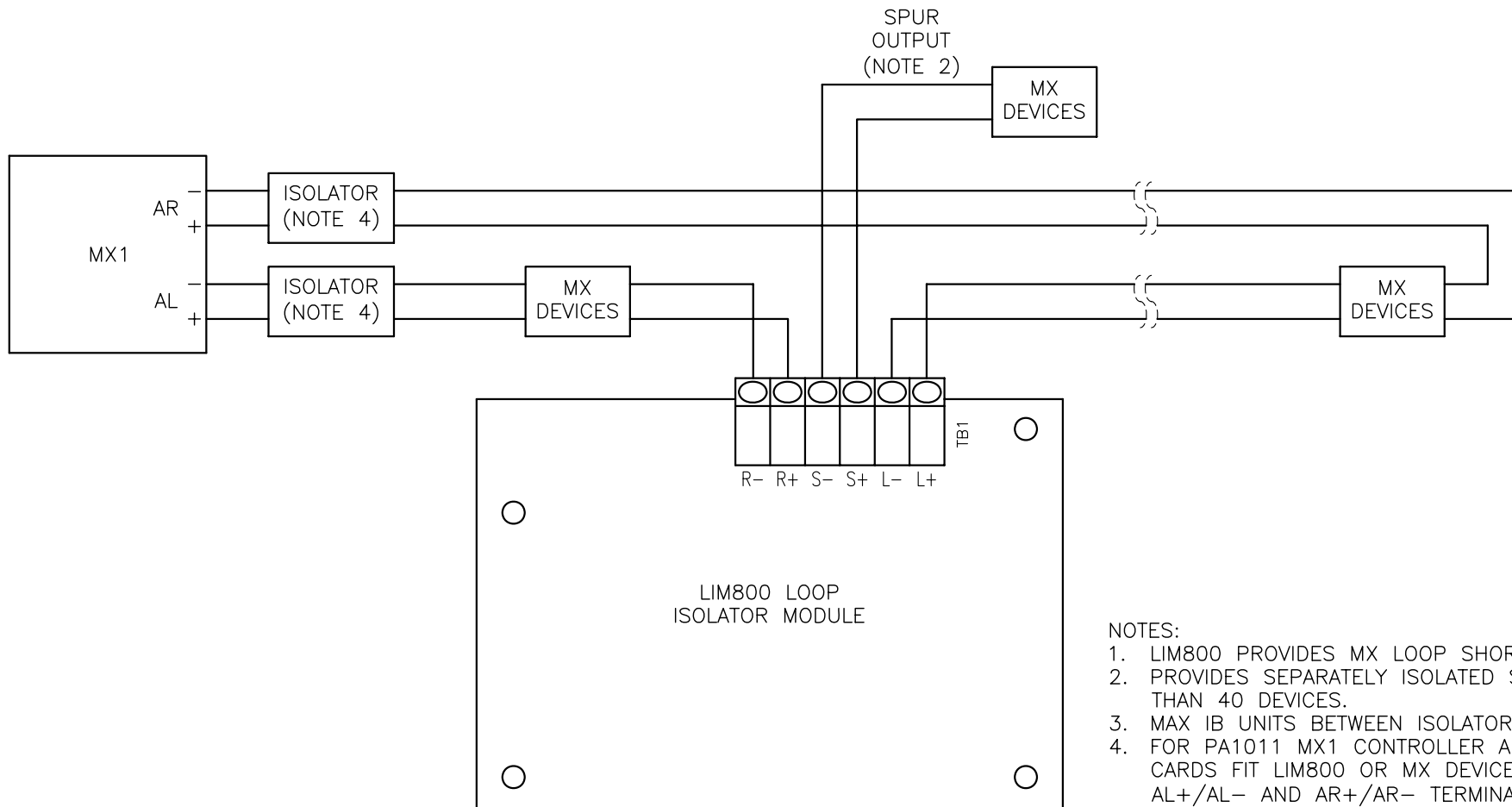

NOTES:

1. LIM800 PROVIDES MX LOOP SHORT CIRCUIT ISOLATION.
2. PROVIDES SEPARATELY ISOLATED SPUR OUTPUT TO NO MORE THAN 40 DEVICES.
3. MAX IB UNITS BETWEEN ISOLATORS = 100 IB UNITS.
4. FOR PA1011 MX1 CONTROLLER AND REV 1-2 MX1 LOOP CARDS FIT LIM800 OR MX DEVICE WITH INTEGRAL SCI AT MX1 AL+/AL- AND AR+/AR- TERMINALS INSIDE THE MX1 CABINET OR IMMEDIATELY ADJACENT BOX. NOT REQUIRED FOR PA1081 OR REV 3 ONWARDS LOOP CARDS.
5. FIT NO MORE THAN 40 DEVICES (MX DETECTORS/MODULES + ACTUATING DEVICES ON CIM/DIM/MIM/MIO INPUTS AND EACH SEPARATE OUTPUT FUNCTION ON MIO AND EACH SNM AND RIM MODULE) BETWEEN ISOLATORS. MX DETECTORS IN ISOLATOR BASES NEED NOT BE COUNTED.

CONFIDENTIAL: THIS DOCUMENT MUST NOT BE COPIED NOR THE CONTENTS PASSED ON TO ANY THIRD PARTY WITHOUT THE CONSENT OF THE COMPANY.

UNLESS OTHERWISE STATED: ALL DIMENSIONS IN MILLIMETRES. DO NOT SCALE. TOLERANCES ARE TO BE: 1 DECIMAL PLACE ±0.5, 2 DECIMAL PLACES ±0.3, 3 DECIMAL PLACES ±0.1

3rd ANGLE PROJECTION

ISS/REV	AMENDMENTS	ECO	DRN	CHKD	AUTH	APVD	DATE
A	ORIGINAL	-	KJS	RAC	RAC	DSCP	25-6-08
B	NOTE 4 UPDATED.	4167	KJS	LSC	RC	DP	13-9-10

tyco / Safety Products

TYCO SAFETY PRODUCTS
17 MARY MULLER DRIVE
P.O. BOX 19545
CHRISTCHURCH, PH: +64 3 3895096
NEW ZEALAND. FAX: +64 3 3895938

MX1
LIM800 LOOP ISOLATOR MODULE
WIRING DIAGRAM

DRAWING No: 1982-71 SHEET 116 of N

A3	ISS/REV B	PART No:	
----	-----------	----------	--

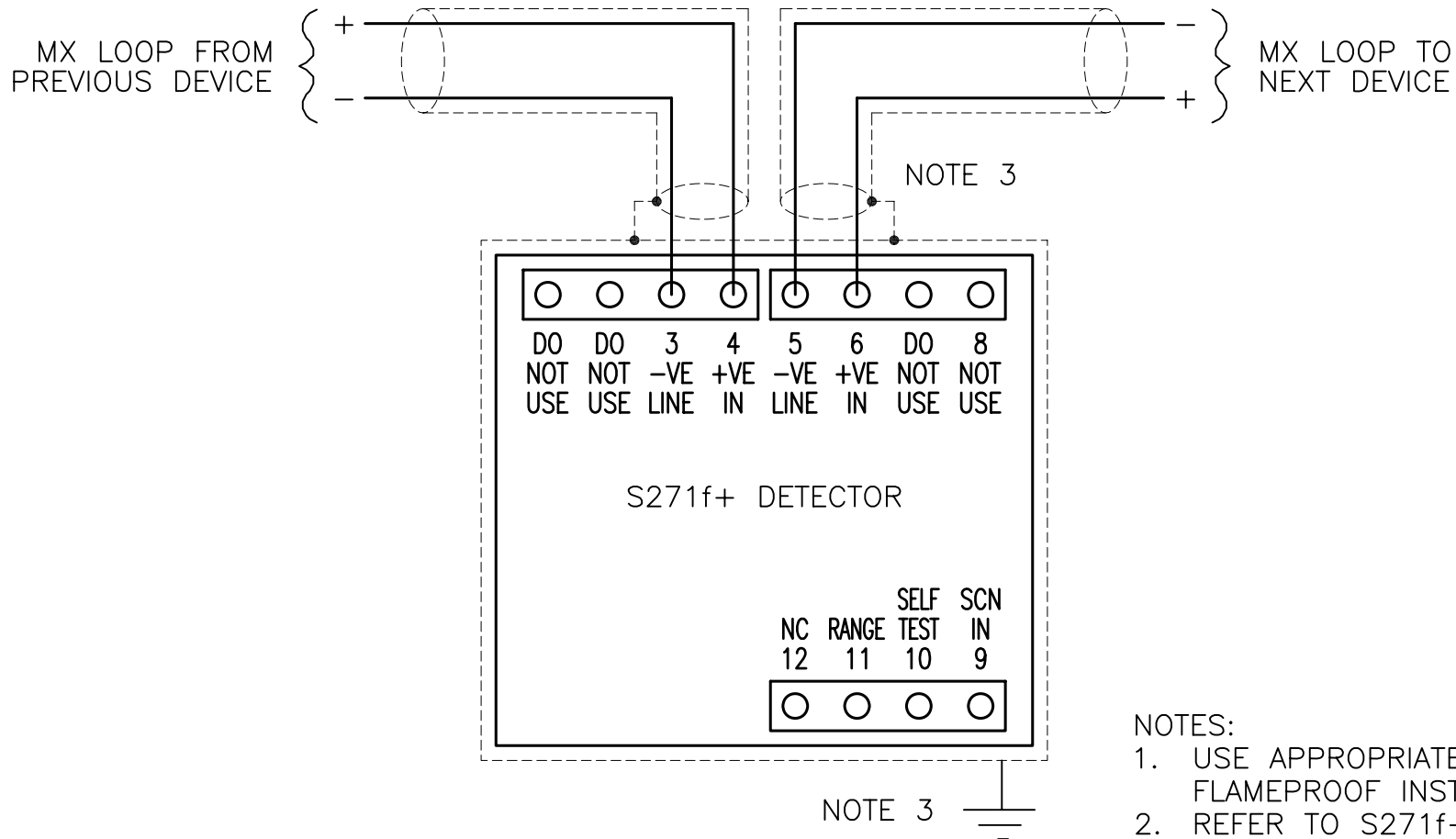

- NOTES:
1. USE APPROPRIATE CABLE PROTECTION FOR FLAMEPROOF INSTALLATIONS.
 2. REFER TO S271f+ INFORMATION FOR RANGE AND SELF TEST WIRING.
 3. REFER TO S271f+ USER MANUAL FOR CABLING AND EARTHING REQUIREMENTS.

CONFIDENTIAL: THIS DOCUMENT MUST NOT BE COPIED NOR THE CONTENTS PASSED ON TO ANY THIRD PARTY WITHOUT THE CONSENT OF THE COMPANY.

UNLESS OTHERWISE STATED: ALL DIMENSIONS IN MILLIMETRES. DO NOT SCALE. TOLERANCES ARE TO BE: 1 DECIMAL PLACE ±0.5, 2 DECIMAL PLACES ±0.3, 3 DECIMAL PLACES ±0.1

3rd ANGLE PROJECTION

ISS/REV	AMENDMENTS	ECO	DRN	CHKD	AUTH	APVD	DATE
A	ORIGINAL	-	KJS	RAC	RAC	DSCP	8-08-08

tyco / Safety Products
 TYCO SAFETY PRODUCTS
 17 MARY MULLER DRIVE
 P.O. BOX 19545
 CHRISTCHURCH, PH: +64 3 3895096
 NEW ZEALAND. FAX: +64 3 3895938

MX1
S271f+ FLAMEPROOF DETECTOR
WIRING DIAGRAM

DRAWING No: 1982-71 SHEET 117 of N

A3	ISS/REV A	PART No:	
----	-----------	----------	--

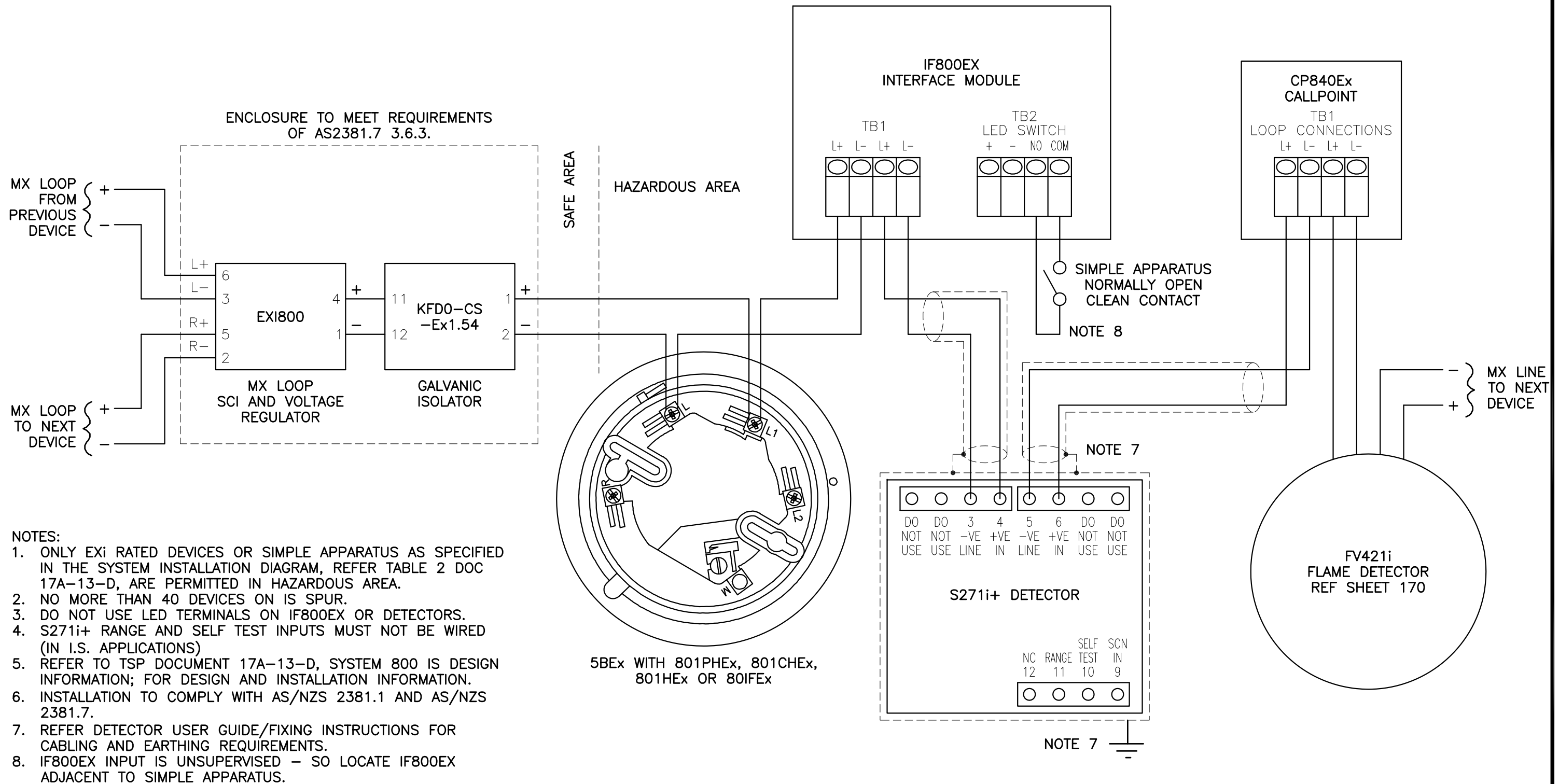

- NOTES:
1. ONLY EXi RATED DEVICES OR SIMPLE APPARATUS AS SPECIFIED IN THE SYSTEM INSTALLATION DIAGRAM, REFER TABLE 2 DOC 17A-13-D, ARE PERMITTED IN HAZARDOUS AREA.
 2. NO MORE THAN 40 DEVICES ON IS SPUR.
 3. DO NOT USE LED TERMINALS ON IF800EX OR DETECTORS.
 4. S271i+ RANGE AND SELF TEST INPUTS MUST NOT BE WIRED (IN I.S. APPLICATIONS)
 5. REFER TO TSP DOCUMENT 17A-13-D, SYSTEM 800 IS DESIGN INFORMATION; FOR DESIGN AND INSTALLATION INFORMATION.
 6. INSTALLATION TO COMPLY WITH AS/NZS 2381.1 AND AS/NZS 2381.7.
 7. REFER DETECTOR USER GUIDE/FIXING INSTRUCTIONS FOR CABLING AND EARTHING REQUIREMENTS.
 8. IF800EX INPUT IS UNSUPERVISED - SO LOCATE IF800EX ADJACENT TO SIMPLE APPARATUS.

CONFIDENTIAL: THIS DOCUMENT MUST NOT BE COPIED NOR THE CONTENTS PASSED ON TO ANY THIRD PARTY WITHOUT THE CONSENT OF THE COMPANY.

UNLESS OTHERWISE STATED: ALL DIMENSIONS IN MILLIMETRES. DO NOT SCALE. TOLERANCES ARE TO BE: 1 DECIMAL PLACE ±0.5, 2 DECIMAL PLACES ±0.3, 3 DECIMAL PLACES ±0.1

3rd ANGLE PROJECTION

ISS/REV	AMENDMENTS	ECO	DRN	CHKD	AUTH	APVD	DATE
A	ORIGINAL	-	KJS	RAC	RAC	DSCP	10-7-08
B	FV421i DETECTOR ADDED.	5207	KJS	RC	MH	DC	8-2-19

© 2019 Johnson Controls. All rights reserved. All specifications and other information shown were current as of document revision date and are subject to change without notice.

JOHNSON CONTROLS
 17 MARY MULLER DRIVE
 P.O. BOX 19545
 CHRISTCHURCH, PH: +64 3 3895096
 NEW ZEALAND. FAX: +64 3 3895938

MX1
MX INTRINSICALLY SAFE DEVICES
WIRING DIAGRAM

DRAWING No: 1982-71 SHEET 118 of N

A3	ISS/REV B	PART No:	
-----------	------------------	----------	--

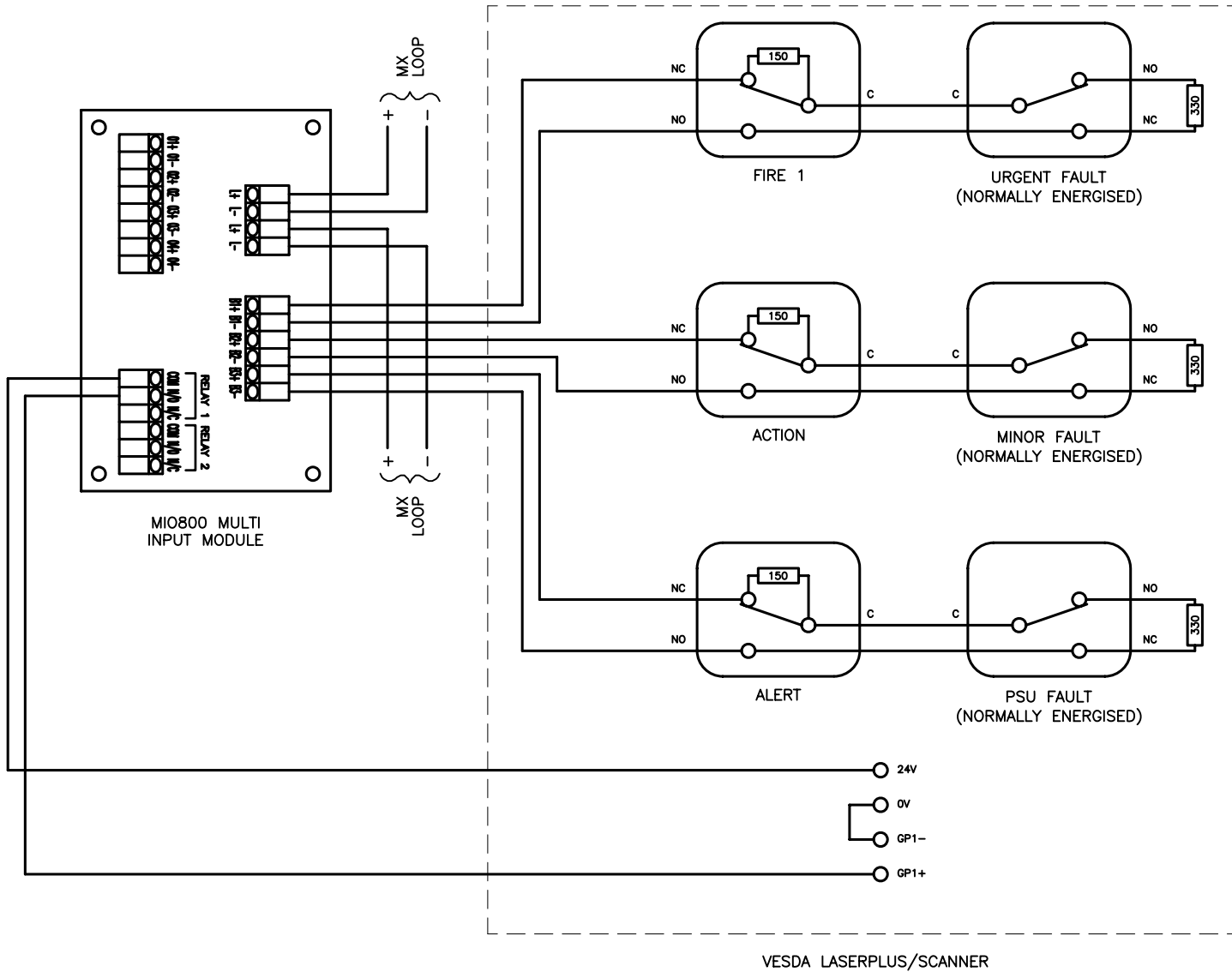

MIO800	VESDA STATES
I/P 1	FIRE 1 AND URGENT FAULT
I/P 2	ACTION AND MINOR FAULT
I/P 3	ALERT AND PSU FAULT
O/P 3	RESET (OPTIONAL)

NOTES:

- IT IS RECOMMENDED THE VESDA UNIT BE PROGRAMMED SO THAT RELAY 3 DROPS OUT ON URGENT FAULT OR ISOLATE. THUS ISOLATING THE VESDA WILL CREATE A FAULT ON THE MX1.

CONFIDENTIAL: THIS DOCUMENT MUST NOT BE COPIED NOR THE CONTENTS PASSED ON TO ANY THIRD PARTY WITHOUT THE CONSENT OF THE COMPANY.

UNLESS OTHERWISE STATED: ALL DIMENSIONS IN MILLIMETRES. DO NOT SCALE. TOLERANCES ARE TO BE: 1 DECIMAL PLACE ± 0.5 , 2 DECIMAL PLACES ± 0.3 , 3 DECIMAL PLACES ± 0.1

3rd ANGLE PROJECTION

ISS/REV	AMENDMENTS	ECO	DRN	CHKD	AUTH	APVD	DATE
A	ORIGINAL	-	KJS	RAC	RAC	DSCP	12-2-09

tyco / Safety Products

TYCO SAFETY PRODUCTS
17 MARY MULLER DRIVE
P.O. BOX 19545
CHRISTCHURCH, PH: +64 3 3895096
NEW ZEALAND. FAX: +64 3 3895938

MX1
MIO800 LASERPLUS / SCANNER
WIRING DIAGRAM

DRAWING No: 1982-71 SHEET 119 of N

A3	ISS/REV A	PART No:
----	-----------	----------

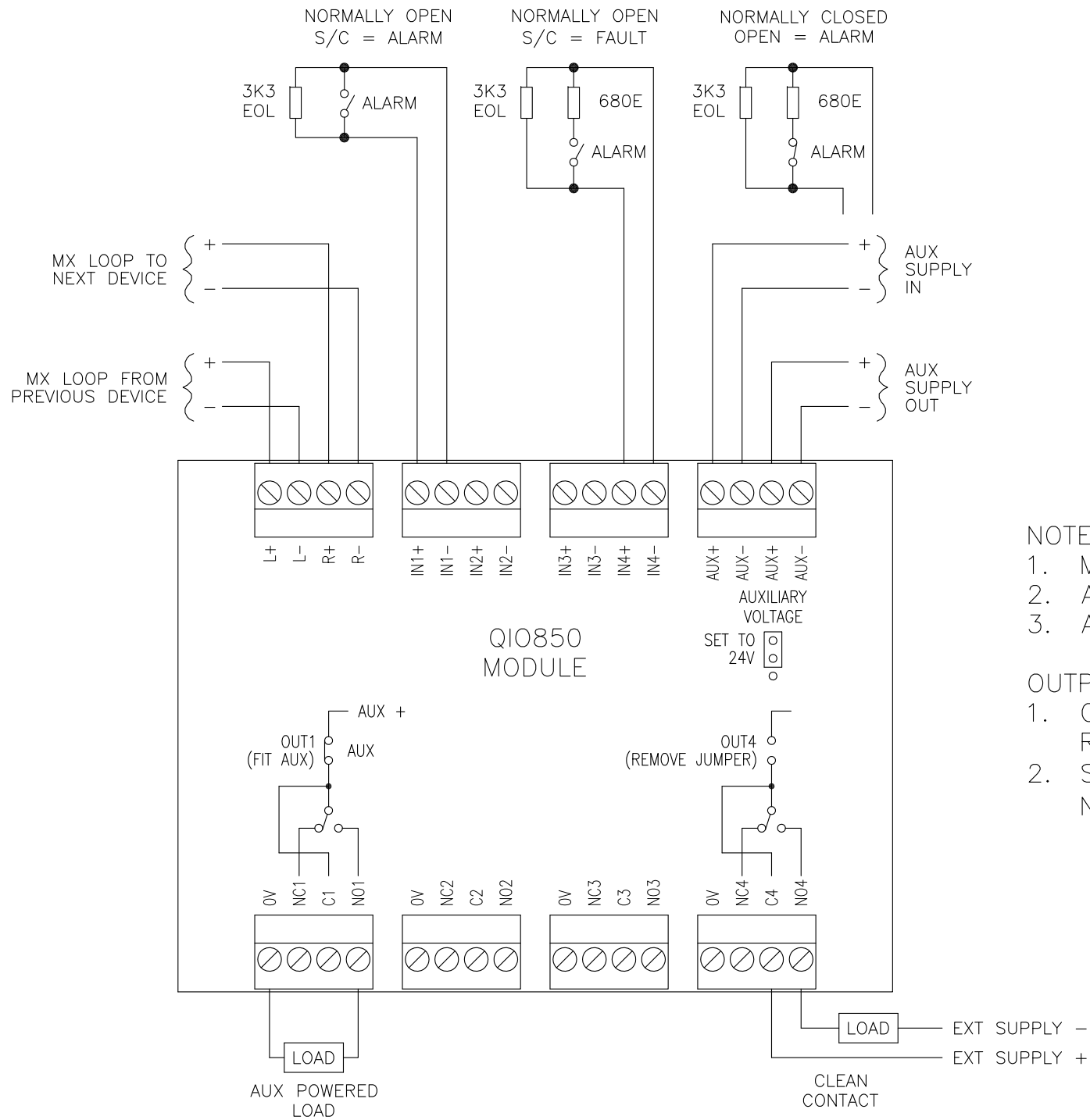

NOTES:

1. MAX INPUT CABLE RESISTANCE 50Ω.
2. AUX SUPPLY 24V DC NOMINAL TO SUIT LOADS.
3. AUX SUPPLY FAULT 18V DC ± 1V.

OUTPUT OPTIONS:

1. CLEAN CONTACT – REMOVE OUT X JUMPER – USE C, NO, NC RELAY AS REQUIRED.
2. SWITCHED AUX O/P – FIT OUT X JUMPER TO AUX POSITION (PIN 2–3). USE NO FOR SWITCHED AUX+ OUTPUT. WIRE TO LOAD AND BACK TO 0V (AUX–).

CONFIDENTIAL: THIS DOCUMENT MUST NOT BE COPIED NOR THE CONTENTS PASSED ON TO ANY THIRD PARTY WITHOUT THE CONSENT OF THE COMPANY.

UNLESS OTHERWISE STATED: ALL DIMENSIONS IN MILLIMETRES. DO NOT SCALE. TOLERANCES ARE TO BE: 1 DECIMAL PLACE ±0.5, 2 DECIMAL PLACES ±0.3, 3 DECIMAL PLACES ±0.1

3rd ANGLE PROJECTION

ISS/REV	AMENDMENTS	ECO	DRN	CHKD	AUTH	APVD	DATE
A	ORIGINAL	-	KJS	JG	RC	DP	17-12-14
B	NOTES UPDATED, LINKS SHOWN.	ECS1778	KJS	PV	RC	DC	16-10-18

© 2018 Johnson Controls. All rights reserved. All specifications and other information shown were current as of document revision date and are subject to change without notice.

JOHNSON CONTROLS
 17 MARY MULLER DRIVE
 P.O. BOX 19545
 CHRISTCHURCH, PH: +64 3 3895096
 NEW ZEALAND. FAX: +64 3 3895938

MX1
QIO850 QUAD I/O MODULE
WIRING DIAGRAM

DRAWING No: **1982-71** SHEET **161** of **N**

A3 | ISS/REV **B** | PART No:

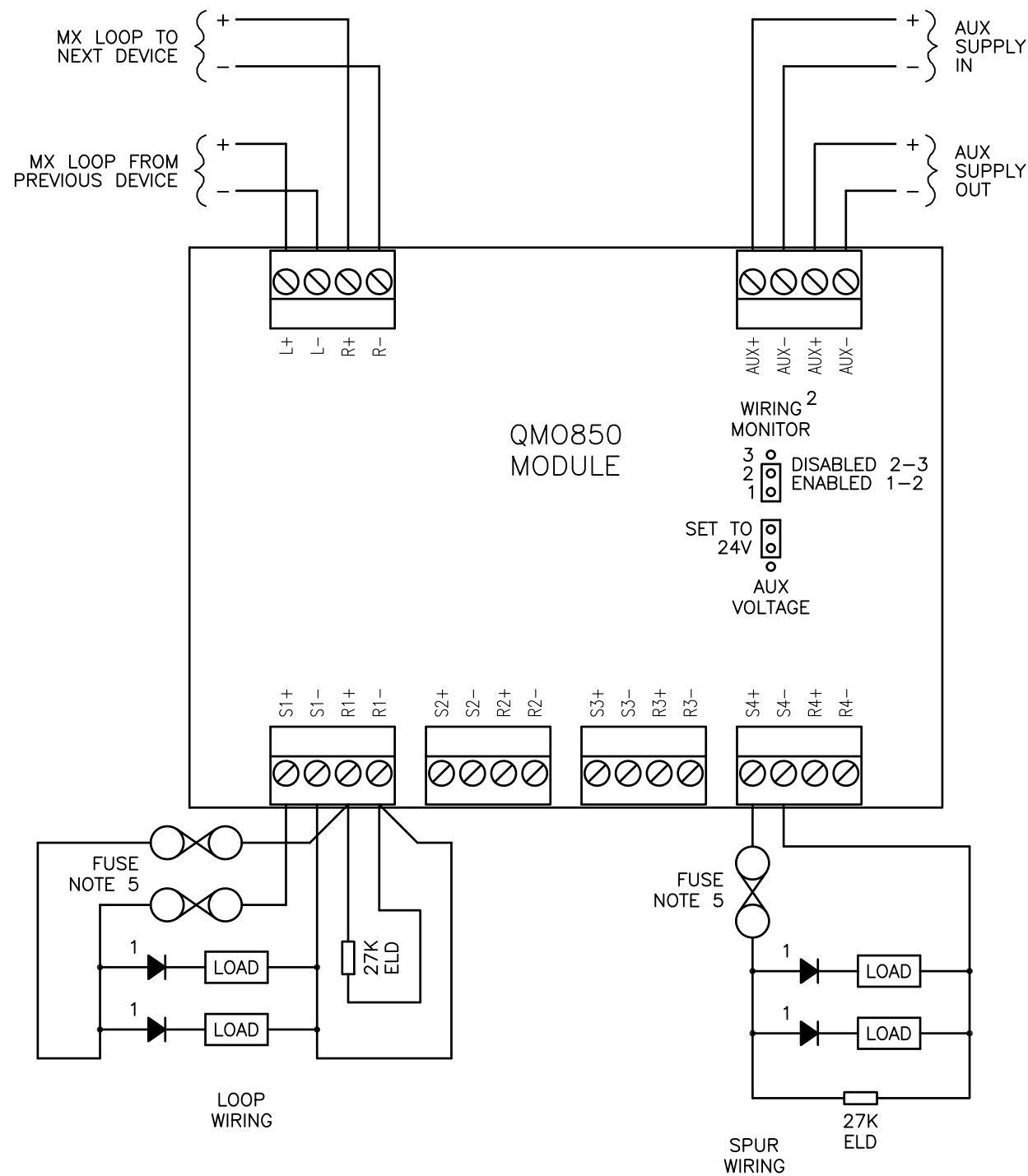

NOTES:

1. LOAD REQUIRES SERIES DIODE IF NOT FITTED INTERNALLY.
2. FIT WIRING MONITOR JUMPER TO ENABLED (1-2) TO ENABLE SUPERVISION OF WIRING RESISTANCE TO AUX SUPPLY. FIT TO DISABLED (2-3) TO DISABLE.
3. AUX SUPPLY 24V DC NOMINAL.
4. AUX SUPPLY FAULT 18V ± 1V.
5. WHERE A COMMON AUX SUPPLY IS USED FOR MULTIPLE OUTPUTS (E.G. FLOOR/AREAS OF ALARM DEVICES) EACH OUTPUT NEEDS TO BE FUSED, WITH A RATING JUST GREATER THAN THE MAXIMUM LOAD CURRENT.
6. EACH OUTPUT SUITABLE FOR 1 FLOOR OR AREA <2000m² OF ALARM DEVICES.

CONFIDENTIAL: THIS DOCUMENT MUST NOT BE COPIED NOR THE CONTENTS PASSED ON TO ANY THIRD PARTY WITHOUT THE CONSENT OF THE COMPANY.

UNLESS OTHERWISE STATED: ALL DIMENSIONS IN MILLIMETRES. DO NOT SCALE. TOLERANCES ARE TO BE: 1 DECIMAL PLACE ±0.5, 2 DECIMAL PLACES ±0.3, 3 DECIMAL PLACES ±0.1

3rd ANGLE PROJECTION

ISS/REV	AMENDMENTS	ECO	DRN	CHKD	AUTH	APVD	DATE
A	ORIGINAL	-	KJS	JG	RC	DP	17-12-14
B	NOTES 5, 6 & FUSE ADDED.	5276	KJS	RC	MH	DC	20-1-20

© 2019 Johnson Controls. All rights reserved. All specifications and other information shown were current as of document revision date and are subject to change without notice.

JOHNSON CONTROLS
 17 MARY MULLER DRIVE
 P.O. BOX 19545
 CHRISTCHURCH, PH: +64 3 3895096
 NEW ZEALAND. FAX: +64 3 3895938

MX1
QMO850 MONITORED OUTPUT MODULE
WIRING DIAGRAM

DRAWING No: **1982-71** SHEET **162** of **N**

A3	ISS/REV B	PART No:	
-----------	------------------	----------	--

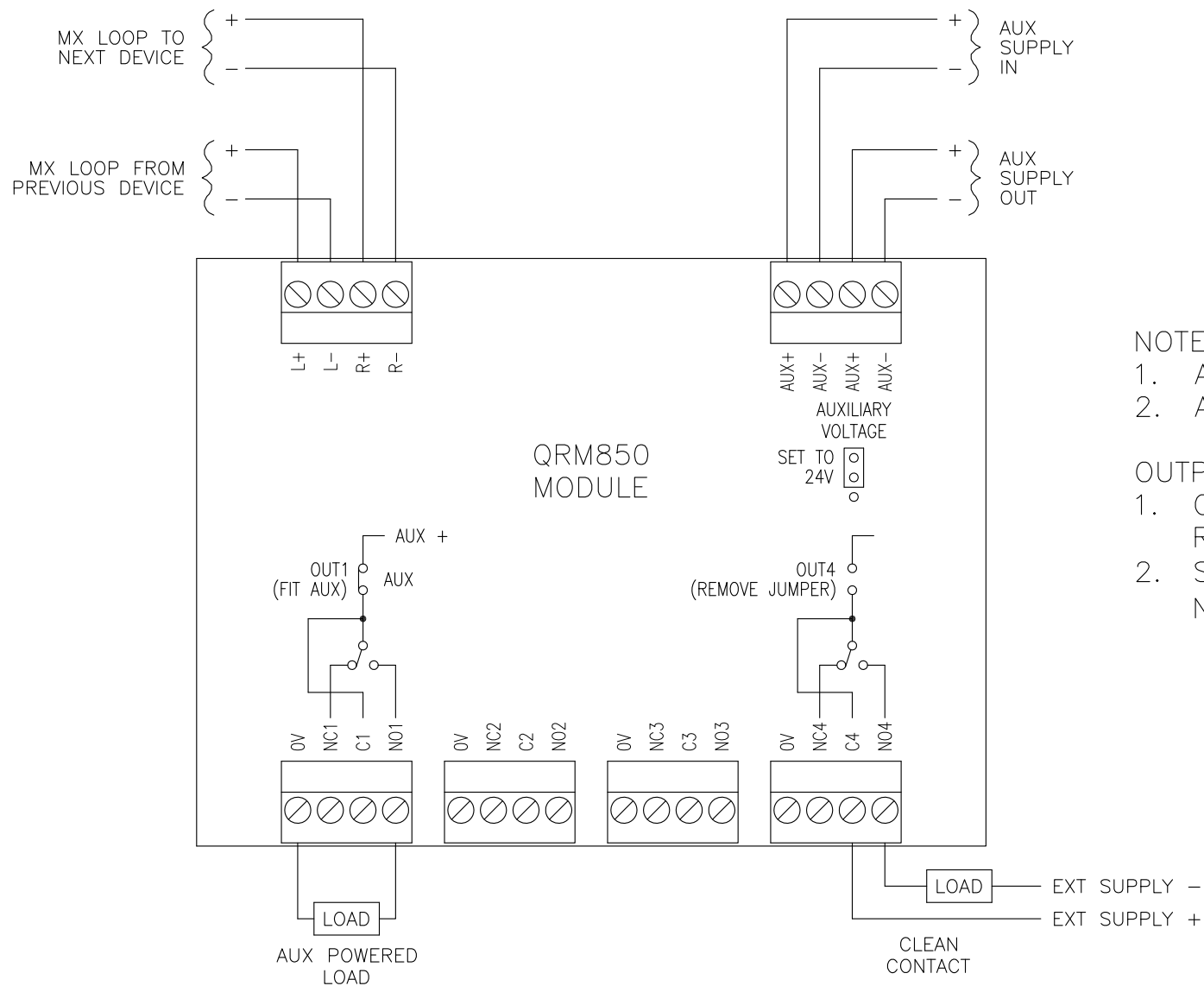

NOTES:

1. AUX SUPPLY 24V DC NOMINAL TO SUIT LOADS.
2. AUX SUPPLY FAULT 18V DC \pm 1V.

OUTPUT OPTIONS:

1. CLEAN CONTACT – REMOVE OUT X JUMPER – USE C, NO, NC RELAY AS REQUIRED.
2. SWITCHED AUX O/P – FIT OUT X JUMPER TO AUX POSITION (PIN 2–3). USE NO FOR SWITCHED AUX+ OUTPUT. WIRE TO LOAD AND BACK TO 0V (AUX–).

CONFIDENTIAL: THIS DOCUMENT MUST NOT BE COPIED NOR THE CONTENTS PASSED ON TO ANY THIRD PARTY WITHOUT THE CONSENT OF THE COMPANY.

UNLESS OTHERWISE STATED: ALL DIMENSIONS IN MILLIMETRES. DO NOT SCALE. TOLERANCES ARE TO BE: 1 DECIMAL PLACE \pm 0.5, 2 DECIMAL PLACES \pm 0.3, 3 DECIMAL PLACES \pm 0.1

3rd ANGLE PROJECTION

ISS/REV	AMENDMENTS	ECO	DRN	CHKD	AUTH	APVD	DATE
A	ORIGINAL	-	KJS	JG	RC	DP	17-12-14
B	NOTES UPDATED, LINKS SHOWN.	ECS1778	KJS	PV	RC	DC	16-10-18

© 2018 Johnson Controls. All rights reserved. All specifications and other information shown were current as of document revision date and are subject to change without notice.

JOHNSON CONTROLS
 17 MARY MULLER DRIVE
 P.O. BOX 19545
 CHRISTCHURCH, PH: +64 3 3895096
 NEW ZEALAND. FAX: +64 3 3895938

MX1
QRM850 QUAD RELAY MODULE
WIRING DIAGRAM

DRAWING No: **1982-71** SHEET **163** of **N**

A3	ISS/REV B	PART No:	
-----------	------------------	----------	--

MX LOOP FROM PREVIOUS DEVICE } +
 - } MX LOOP TO NEXT DEVICE

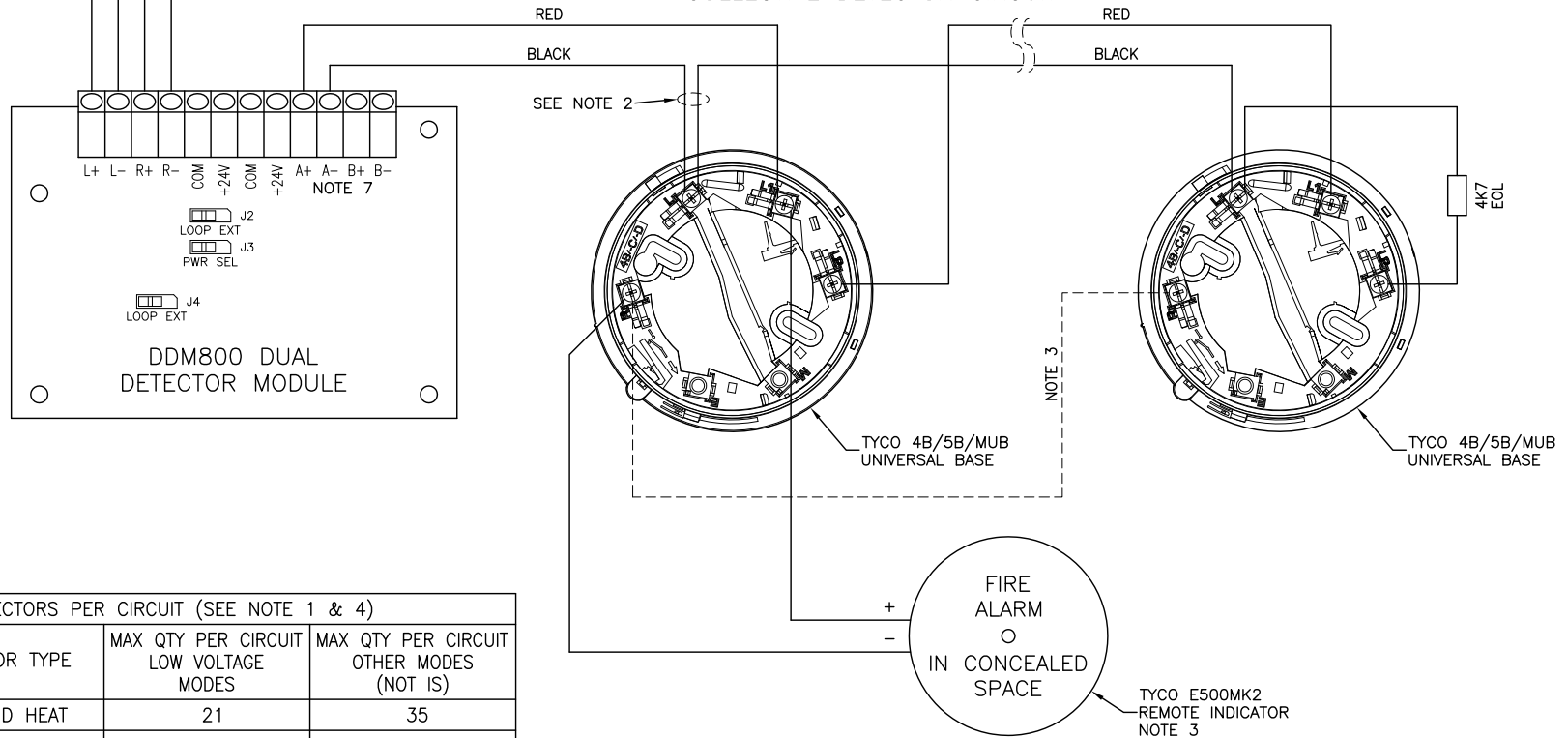

MAX QTY OF DETECTORS PER CIRCUIT (SEE NOTE 1 & 4)			
DETECTOR MODEL	DETECTOR TYPE	MAX QTY PER CIRCUIT LOW VOLTAGE MODES	MAX QTY PER CIRCUIT OTHER MODES (NOT IS)
614CH	CO AND HEAT	21	35
614I	IONISATION	25	40
614P	PHOTOELECTRIC	25	40
614T	HEAT	17	29
S/C	HARD CONTACT	40	40
USED IN 4B/5B/MUB BASES			

- NOTES:
- REFER LT0441 MX1 DESIGN MANUAL FOR OTHER DETECTOR COMPATIBILITY.
 - CUT WIRES BEFORE CONNECTING TO TERMINAL L TO MAINTAIN SUPERVISION. DO NOT LOOP WIRE UNDERNEATH TERMINAL L.
 - MULTIPLE BASES CAN DRIVE A COMMON REMOTE INDICATOR BY LINKING BASES AS SHOWN.
 - WHEN USING MULTIPLE DETECTOR TYPES ON ONE CIRCUIT, THE SUM OF EACH TYPE'S QUANTITY AS A PROPORTION OF ITS MAXIMUM MUST NOT EXCEED 1, E.G. 22 X 614I AND 16 X 614T ARE NOT PERMITTED AS $22/40 + 16/29$ IS GREATER THAN 1.
 - MAX DETECTOR CURRENT:
 1.5mA PER CIRCUIT - LOW VOLTAGE MODE.
 2.5mA PER CIRCUIT - OTHER MODES.
 1.0mA PER CIRCUIT - IS MODE.
 - MAX COLLECTIVE CIRCUIT RESISTANCE: 50 OHMS.
 - BOTH Cct A AND B CAN BE USED.

CONFIDENTIAL: THIS DOCUMENT MUST NOT BE COPIED NOR THE CONTENTS PASSED ON TO ANY THIRD PARTY WITHOUT THE CONSENT OF THE COMPANY.

UNLESS OTHERWISE STATED: ALL DIMENSIONS IN MILLIMETRES. DO NOT SCALE. TOLERANCES ARE TO BE: 1 DECIMAL PLACE ±0.5, 2 DECIMAL PLACES ±0.3, 3 DECIMAL PLACES ±0.1

3rd ANGLE PROJECTION

ISS/REV	AMENDMENTS	ECO	DRN	CHKD	AUTH	APVD	DATE
A	ORIGINAL	-	KJS	RC	RC	DP	22-1-15

tyco
 Fire Protection Products

TYCO FIRE PROTECTION PRODUCTS
 17 MARY MULLER DRIVE
 P.O. BOX 19545
 CHRISTCHURCH, PH: +64 3 3895096
 NEW ZEALAND. FAX: +64 3 3895938

**MX1, LOOP POWERED
 DDM800 DUAL DETECTOR MODULE
 WIRING DIAGRAM**

DRAWING No: 1982-71 SHEET 164 of N

A3	ISS/REV A	PART No:	
----	-----------	----------	--

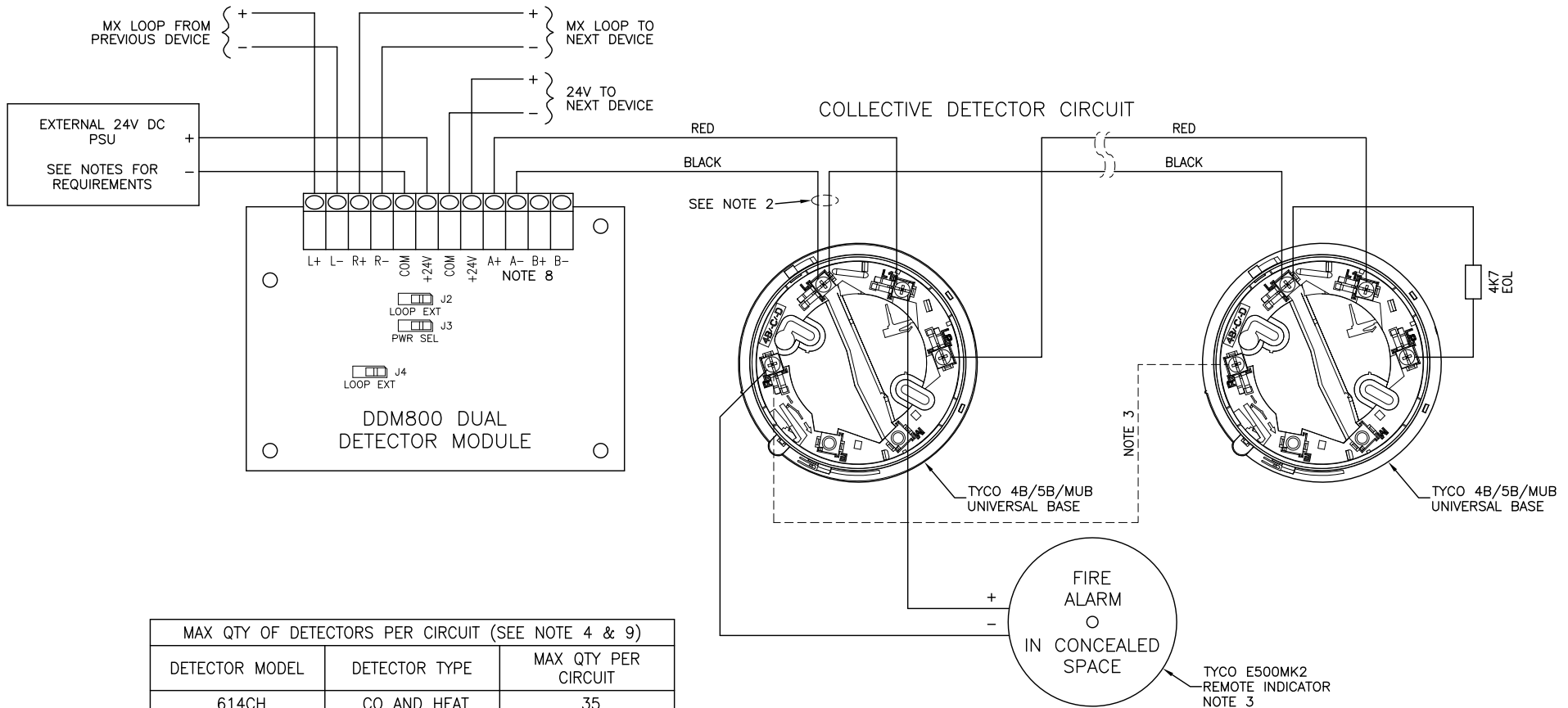

MAX QTY OF DETECTORS PER CIRCUIT (SEE NOTE 4 & 9)		
DETECTOR MODEL	DETECTOR TYPE	MAX QTY PER CIRCUIT
614CH	CO AND HEAT	35
614I	IONISATION	40
614P	PHOTOELECTRIC	40
614T	HEAT	29
S/C	HARD CONTACT	40
USED IN 4B/5B/MUB BASES		

- NOTES:
- IF EXTERNAL PSU IS REMOTE, DO NOT CONNECT MORE THAN 40 COLLECTIVE DETECTORS PER CABLE.
 - CUT WIRES BEFORE CONNECTING TO TERMINAL L TO MAINTAIN SUPERVISION. DO NOT LOOP WIRE UNDERNEATH TERMINAL L.
 - MULTIPLE BASES CAN DRIVE A COMMON REMOTE INDICATOR BY LINKING BASES AS SHOWN.
 - WHEN USING MULTIPLE DETECTOR TYPES ON ONE CIRCUIT, THE SUM OF EACH TYPE'S QUANTITY AS A PROPORTION OF ITS MAXIMUM MUST NOT EXCEED 1, E.G. 22 X 614I AND 16 X 614T ARE NOT PERMITTED AS 22/40 + 16/29 IS GREATER THAN 1.
 - MAX DETECTOR CURRENT: 2.5mA PER CIRCUIT, 1.0mA PER CIRCUIT (IS).
 - EXTERNAL SUPPLY: 21.9-29V DC.
CURRENT: 10mA + DETECTORS EACH CIRCUIT USED.
ALARM CURRENT: 52mA.
 - MAX COLLECTIVE CIRCUIT RESISTANCE: 50 OHMS.
 - BOTH Cct A AND B CAN BE USED.
 - REFER LT0441 MX1 DESIGN MANUAL FOR OTHER DETECTOR COMPATIBILITY INFORMATION AND IS WIRING.

CONFIDENTIAL: THIS DOCUMENT MUST NOT BE COPIED NOR THE CONTENTS PASSED ON TO ANY THIRD PARTY WITHOUT THE CONSENT OF THE COMPANY.

UNLESS OTHERWISE STATED: ALL DIMENSIONS IN MILLIMETRES. DO NOT SCALE. TOLERANCES ARE TO BE: 1 DECIMAL PLACE ±0.5, 2 DECIMAL PLACES ±0.3, 3 DECIMAL PLACES ±0.1

3rd ANGLE PROJECTION

ISS/REV	AMENDMENTS	ECO	DRN	CHKD	AUTH	APVD	DATE
A	ORIGINAL	-	KJS	RC	RC	DP	22-1-15

tyco
Fire Protection Products

TYCO FIRE PROTECTION PRODUCTS
17 MARY MULLER DRIVE
P.O. BOX 19545
CHRISTCHURCH, PH: +64 3 3895096
NEW ZEALAND. FAX: +64 3 3895938

**MX1, EXTERNALLY POWERED
DDM800 DUAL DETECTOR MODULE
WIRING DIAGRAM**

DRAWING No: 1982-71 SHEET 165 of N

A3	ISS/REV A	PART No:	
----	-----------	----------	--

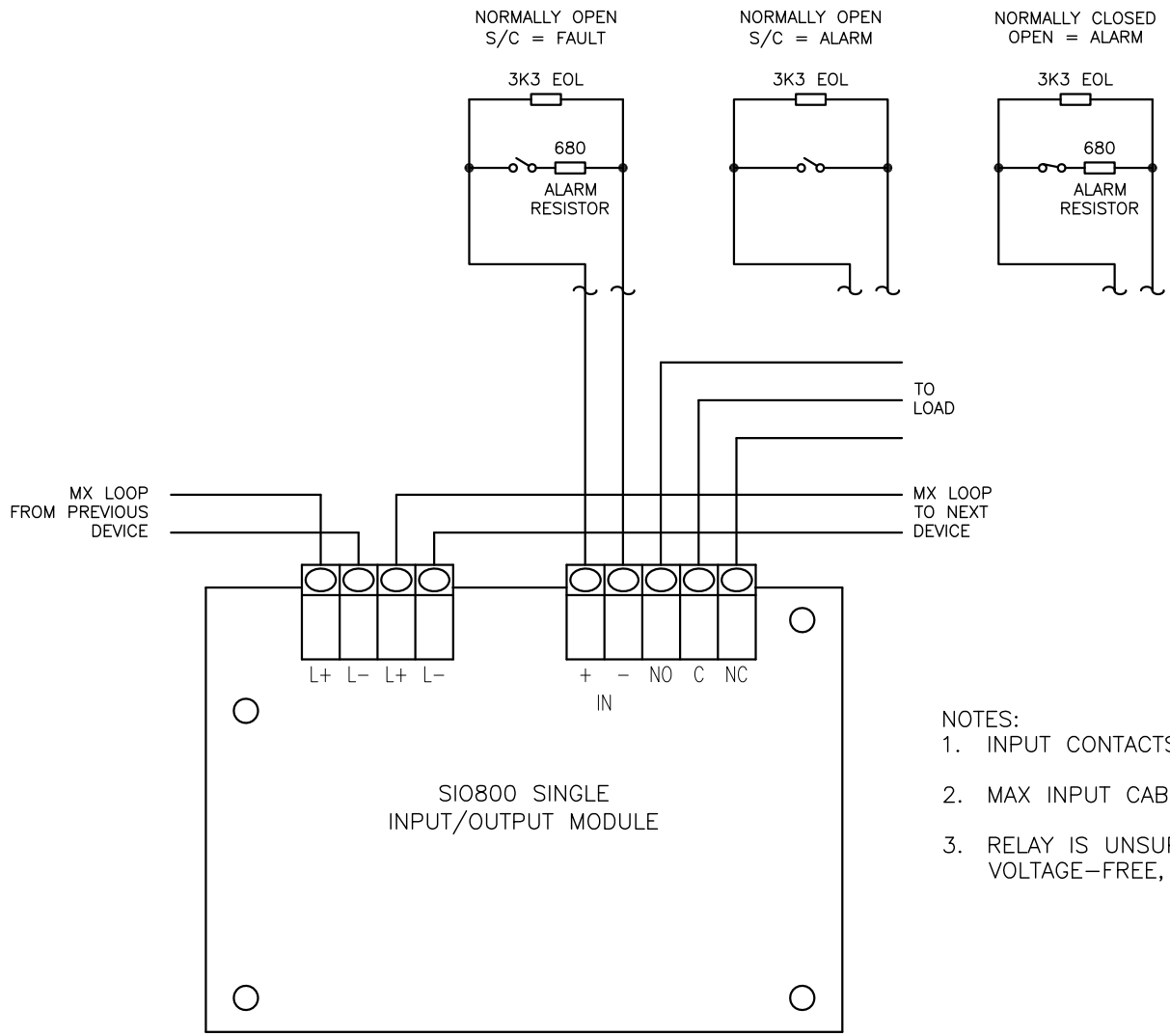

- NOTES:
1. INPUT CONTACTS MUST BE VOLTAGE-FREE.
 2. MAX INPUT CABLE RESISTANCE 50Ω.
 3. RELAY IS UNSUPERVISED, SINGLE POLE, CHANGE-OVER, VOLTAGE-FREE, RATED 2A @ 24V DC RESISTIVE.

CONFIDENTIAL: THIS DOCUMENT MUST NOT BE COPIED NOR THE CONTENTS PASSED ON TO ANY THIRD PARTY WITHOUT THE CONSENT OF THE COMPANY.

UNLESS OTHERWISE STATED: ALL DIMENSIONS IN MILLIMETRES. DO NOT SCALE. TOLERANCES ARE TO BE: 1 DECIMAL PLACE ±0.5, 2 DECIMAL PLACES ±0.3, 3 DECIMAL PLACES ±0.1

3rd ANGLE PROJECTION

ISS/REV	AMENDMENTS	ECO	DRN	CHKD	AUTH	APVD	DATE
A	ORIGINAL	-	KJS	JG	RC	LSC	18-5-17

tyco
Fire Protection Products
 TYCO FIRE PROTECTION PRODUCTS
 17 MARY MULLER DRIVE
 P.O. BOX 19545
 CHRISTCHURCH, PH: +64 3 3895096
 NEW ZEALAND. FAX: +64 3 3895938

MX1
SIO800 SINGLE I/O MODULE
WIRING DIAGRAM

DRAWING No: **1982-71** SHEET **166** of **N**

A3	ISS/REV A	PART No:
-----------	------------------	----------

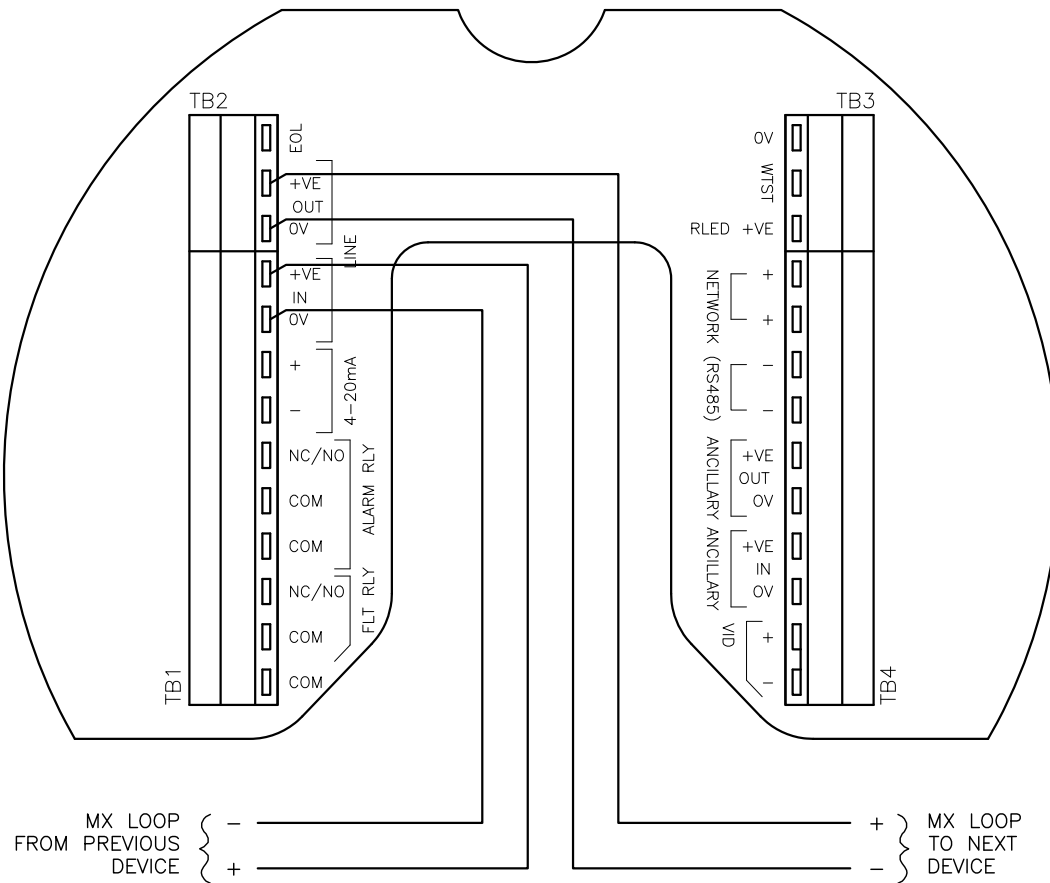

- NOTES:
1. USE APPROPRIATE CABLE PROTECTION FOR FLAMEPROOF INSTALLATIONS.
 2. REFER TO FV400 SERIES DETECTOR FIXING INSTRUCTIONS 120.515.124_FV-D-400-F FOR WALK TEST WIRING.
 3. REFER TO FV400 INSTRUCTIONS FOR CABLING AND EARTHING REQUIREMENTS.
 4. SEE TABLE FOR DIP SWITCH SETTINGS.

SWITCH	FUNCTION	DIP SWITCH SETTING
SW1-1	CONFIGURATION	ON
SW1-2	ALARM DELAY	OFF/OFF = SHORT (3s), OFF/ON = MED (6s),
SW1-3		ON/OFF = LONG (12s), ON/ON = SHORT (3s),
SW1-4	RANGE	OFF/OFF = NORMAL (33m), OFF/ON = HALF (15m),
SW1-5		ON/OFF = CLOSE (<6m), ON/ON = EXTENDED (65m),
SW1-6	ANCILLARY POWER	ON IF ANCILLARY SUPPLY IS USED (DO NOT FIT HDR3 OR HDR4)
SW1-7	ALARM LATCH	ON FOR NON-LATCHING ALARM
SW1-8	FAULT LATCH	OFF FOR NON-LATCHING FAULT
SW2-1	WINDOW HEATER	OFF = NO HEATER, ON = HEATER
SW2-2	OPM	OFF = AUTO OPTICAL PATH MONITORING (WINDOW CLEANLINES)
SW2-3	INTERFACE	ON
SW2-4	INTERFACE	ON
SW2-5	MX MODE	ON
SW2-6	MX MODE	OFF
SW2-7	MX MODE	SET ON TO PROGRAM MX LOOP ADDRESS, THEN SET OFF
SW2-8	<FUTURE>	OFF

CONFIDENTIAL: THIS DOCUMENT MUST NOT BE COPIED NOR THE CONTENTS PASSED ON TO ANY THIRD PARTY WITHOUT THE CONSENT OF THE COMPANY.

UNLESS OTHERWISE STATED: ALL DIMENSIONS IN MILLIMETRES. DO NOT SCALE. TOLERANCES ARE TO BE: 1 DECIMAL PLACE ±0.5, 2 DECIMAL PLACES ±0.3, 3 DECIMAL PLACES ±0.1

3rd ANGLE PROJECTION

ISS/REV	AMENDMENTS	ECO	DRN	CHKD	AUTH	APVD	DATE
A	ORIGINAL	-	KJS	JG	RC	DC	6-6-17

© 2017 Johnson Controls. All rights reserved. All specifications and other information shown were current as of document revision date and are subject to change without notice.

JOHNSON CONTROLS
 17 MARY MULLER DRIVE
 P.O. BOX 19545
 CHRISTCHURCH, PH: +64 3 3895096
 NEW ZEALAND. FAX: +64 3 3895938

MX1
FV4XX FLAMEPROOF DETECTOR
WIRING DIAGRAM

DRAWING No: 1982-71 SHEET 167 of N

A3	ISS/REV A	PART No:	
----	-----------	----------	--

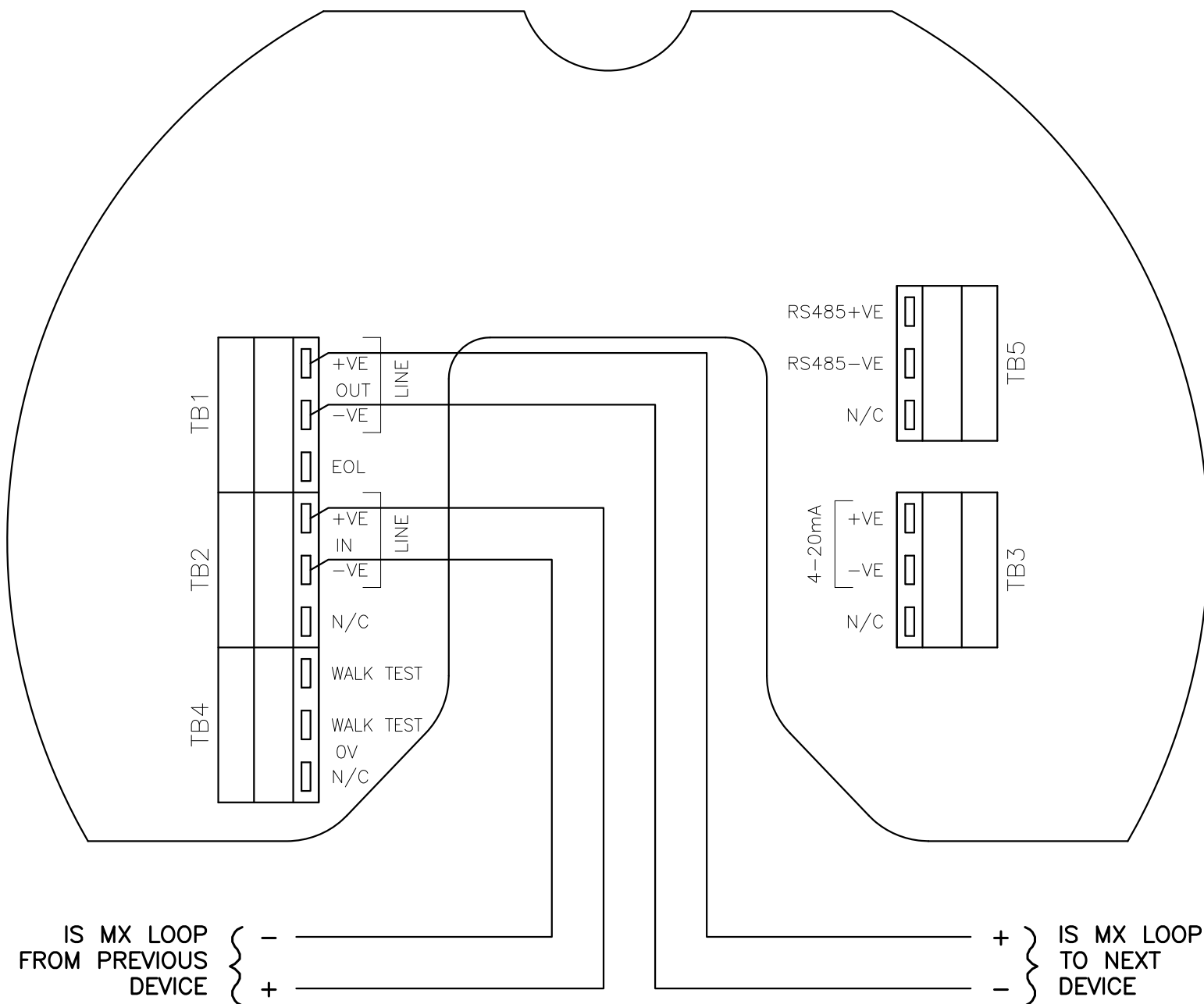

NOTES:

1. USE APPROPRIATE CABLE PROTECTION FOR INTRINSICALLY SAFE INSTALLATIONS.
2. REFER TO FV421i SERIES DETECTOR FIXING INSTRUCTIONS 120.515.204 FOR WALK TEST WIRING, CABLING AND EARTHING REQUIREMENTS.
3. SEE TABLE FOR DIP SWITCH SETTINGS.

SWITCH	FUNCTION	DIP SWITCH SETTING
SW1-1	CONFIGURATION	ON
SW1-2	ALARM DELAY	OFF/OFF = SHORT (3s), OFF/ON = MED (6s),
SW1-3		ON/OFF = LONG (12s), ON/ON = SHORT (3s),
SW1-4	RANGE	OFF/OFF = NORMAL (33m), OFF/ON = HALF (15m),
SW1-5		ON/OFF = CLOSE (<6m), ON/ON = EXTENDED (65m),
SW1-6	OPM MODE	REFER TO FIXING INSTRUCTIONS
SW1-7	ALARM LATCH	ON FOR NON-LATCHING ALARM
SW1-8	FAULT LATCH	OFF FOR NON-LATCHING FAULT
SW2-1	INTERFACE	ON = MX
SW2-2	INTERFACE	ON = MX
SW2-3	MODE	ON = DIP SWITCH
SW2-4	MODE	OFF

REFER TO 1982-71 SHEET 118
FOR INTERFACING TO MX LOOP

CONFIDENTIAL: THIS DOCUMENT MUST NOT BE COPIED NOR THE CONTENTS PASSED ON TO ANY THIRD PARTY WITHOUT THE CONSENT OF THE COMPANY.

UNLESS OTHERWISE STATED: ALL DIMENSIONS IN MILLIMETRES. DO NOT SCALE. TOLERANCES ARE TO BE: 1 DECIMAL PLACE ±0.5, 2 DECIMAL PLACES ±0.3, 3 DECIMAL PLACES ±0.1

3rd ANGLE PROJECTION

ISS/REV	AMENDMENTS	ECO	DRN	CHKD	AUTH	APVD	DATE
A	ORIGINAL	5207	KJS	RC	MH	DC	8-2-19

© 2019 Johnson Controls. All rights reserved.
All specifications and other information shown were current as of document revision date and are subject to change without notice.

JOHNSON CONTROLS
17 MARY MULLER DRIVE
P.O. BOX 19545
CHRISTCHURCH, PH: +64 3 3895096
NEW ZEALAND. FAX: +64 3 3895938

**MX1
FV421i IS DETECTOR
WIRING DIAGRAM**

DRAWING No: 1982-71 SHEET 170 of N

A3 ISS/REV A PART No:

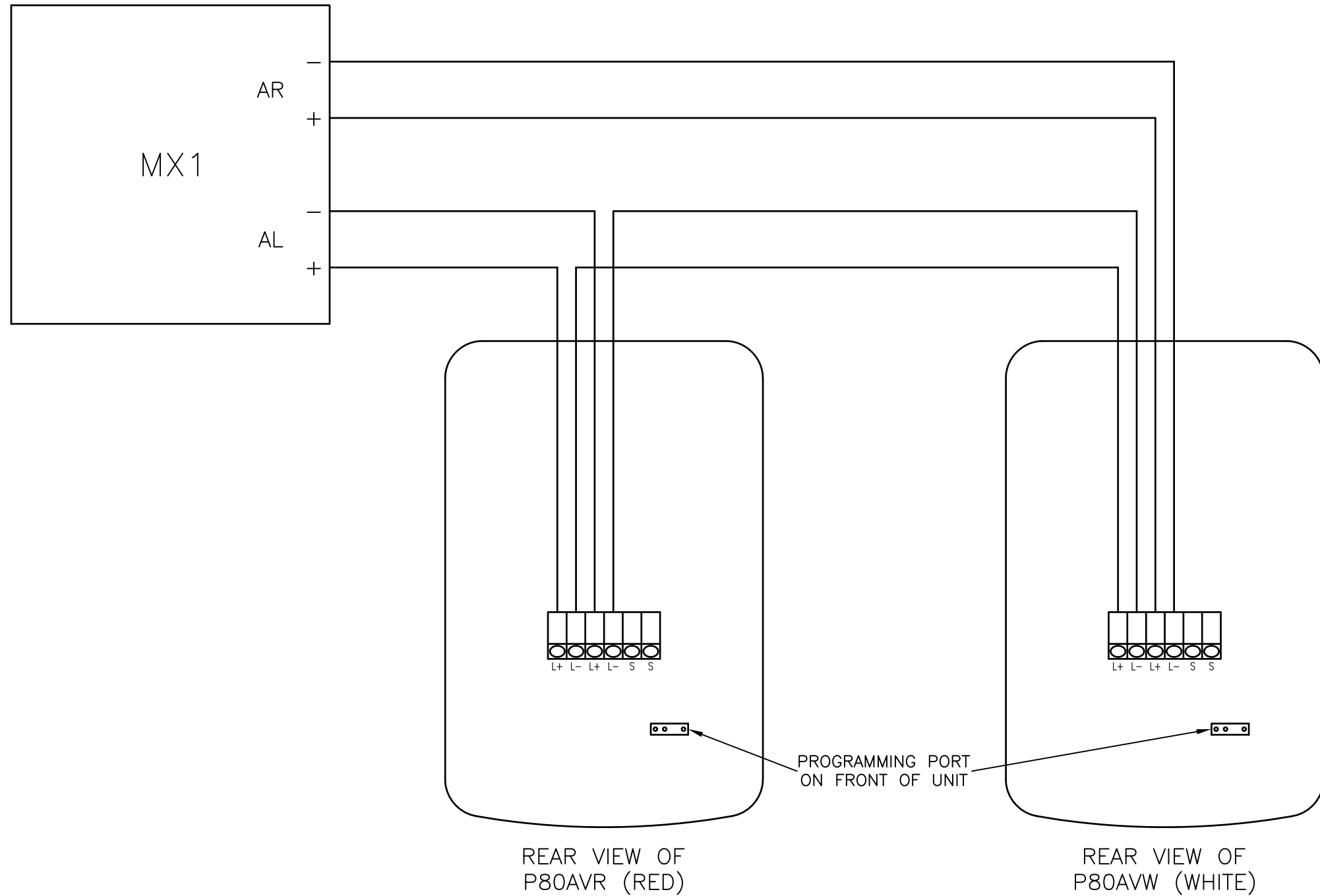

NOTES:

1. PROGRAM REQUIRED LOOP ADDRESS USING 850EMT.
2. CONFIGURE MX1 USING SMARTCONFIG,
HIGH VOL = 100dBA, LOW VOL = 90dBA.

CONFIDENTIAL: THIS DOCUMENT MUST NOT BE COPIED NOR THE CONTENTS PASSED ON TO ANY THIRD PARTY WITHOUT THE CONSENT OF THE COMPANY.

UNLESS OTHERWISE STATED: ALL DIMENSIONS IN MILLIMETRES. DO NOT SCALE. TOLERANCES ARE TO BE: 1 DECIMAL PLACE ± 0.5 , 2 DECIMAL PLACES ± 0.3 , 3 DECIMAL PLACES ± 0.1

3rd ANGLE PROJECTION

ISS/REV	AMENDMENTS	ECO	DRN	CHKD	AUTH	APVD	DATE
A	ORIGINAL	5276	KJS	RC	MH	DC	21-1-20

© 2020 Johnson Controls. All rights reserved.
All specifications and other information shown were current as of document revision date and are subject to change without notice.

JOHNSON CONTROLS
17 MARY MULLER DRIVE
P.O. BOX 19545
CHRISTCHURCH, PH: +64 3 3895096
NEW ZEALAND. FAX: +64 3 3895938

MX1
P80AVR / AVW SOUNDER / BEACON
WIRING DIAGRAM

DRAWING No: 1982-71 SHEET 173 of N

A3 | ISS/REV **A** | PART No:

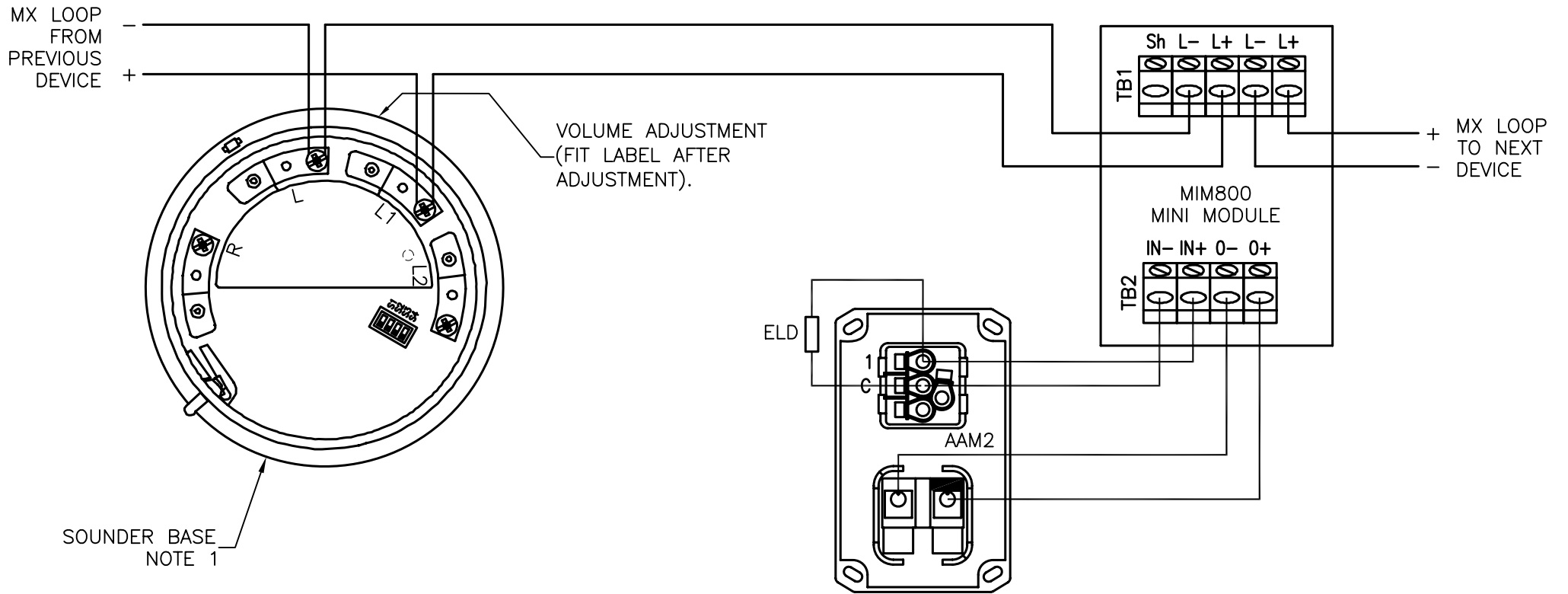

NOTES:

1. REFER SHEET 106 FOR SOUNDER BASE WIRING AND SHEET 108 FOR MIM800 DETAILS.
2. MIM800 LED O/P SHOULD BE MAPPED TO THE DETECTOR ZONE AND CONFIGURED FOR OUTPUT CONTROL = ZONE SECONDARY CONTROL.

CONFIDENTIAL: THIS DOCUMENT MUST NOT BE COPIED NOR THE CONTENTS PASSED ON TO ANY THIRD PARTY WITHOUT THE CONSENT OF THE COMPANY.

UNLESS OTHERWISE STATED:

ALL DIMENSIONS IN MILLIMETRES. DO NOT SCALE. TOLERANCES ARE TO BE:
 1 DECIMAL PLACE ± 0.5 , 2 DECIMAL PLACES ± 0.3 , 3 DECIMAL PLACES ± 0.1

3rd ANGLE PROJECTION

ISS/REV	AMENDMENTS	ECO	DRN	CHKD	AUTH	APVD	DATE
A	ORIGINAL	-	KJS	RAC	RAC	DSCP	8-08-08

tyco / Safety Products

TYCO SAFETY PRODUCTS
 17 MARY MULLER DRIVE
 P.O. BOX 19545
 CHRISTCHURCH, PH: +64 3 3895096
 NEW ZEALAND. FAX: +64 3 3895938

**MX1
AAM2
WIRING DIAGRAM**

DRAWING No: 1982-71 SHEET 120 of N

A3	ISS/REV A	PART No:	
----	-----------	----------	--

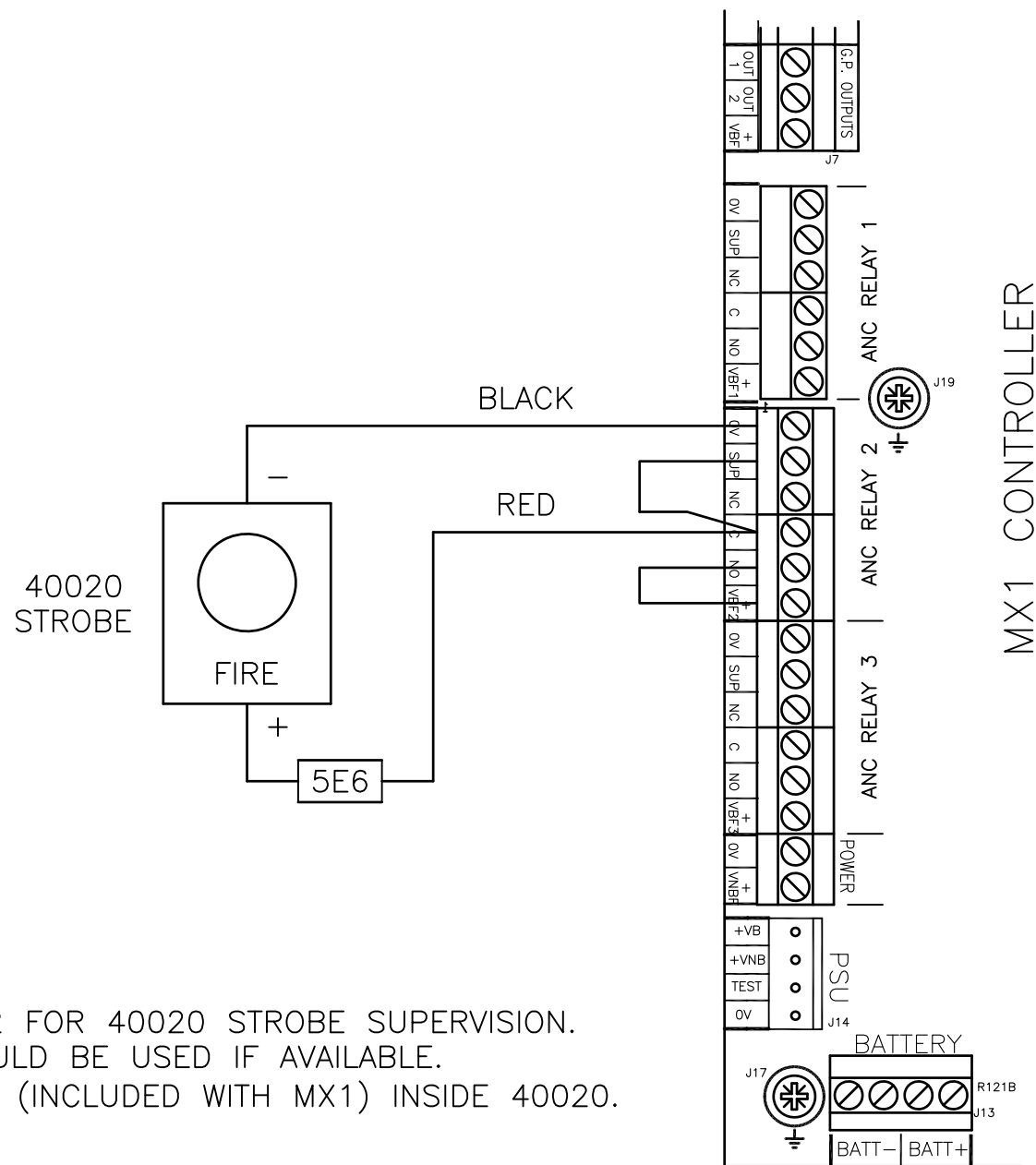

MX1 CONTROLLER

576.080.016
RED IP65 BEACON
SET BOTH DIP
SWITCHES ON
(1Hz, HIGH
POWER)

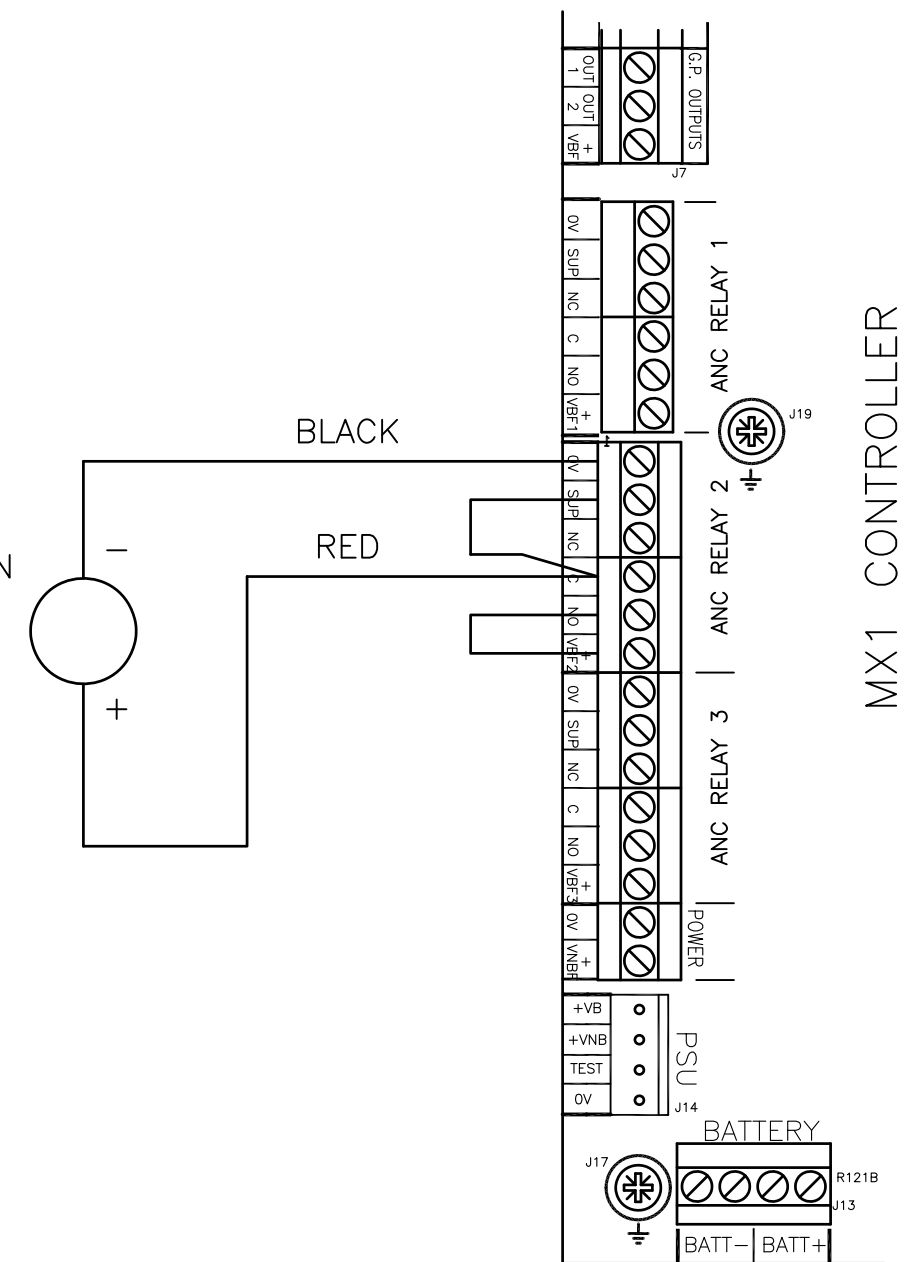

MX1 CONTROLLER

- NOTES:
1. CONFIGURE ANC 2 FOR 40020 STROBE SUPERVISION.
 2. ANC 1 RELAY COULD BE USED IF AVAILABLE.
 3. FIT 5E6 RESISTOR (INCLUDED WITH MX1) INSIDE 40020.

CONFIDENTIAL: THIS DOCUMENT MUST NOT BE COPIED NOR THE CONTENTS PASSED ON TO ANY THIRD PARTY WITHOUT THE CONSENT OF THE COMPANY.

UNLESS OTHERWISE STATED: ALL DIMENSIONS IN MILLIMETRES. DO NOT SCALE. TOLERANCES ARE TO BE: 1 DECIMAL PLACE ± 0.5 , 2 DECIMAL PLACES ± 0.3 , 3 DECIMAL PLACES ± 0.1

3rd ANGLE PROJECTION

ISS/REV	AMENDMENTS	ECO	DRN	CHKD	AUTH	APVD	DATE
A	ORIGINAL	-	KJS	RAC	RAC	DSCP	12-08-08
B	NOTE 3 ADDED. 5E6 RESISTOR ADDED TO STROBE WIRING.	4167	KJS	LSC	RC	DP	13-9-10
C	IP65 BEACON WIRING ADDED.	5276	KJS	RC	MH	DC	21-1-20

© 2019 Johnson Controls. All rights reserved.
All specifications and other information shown were current as of document revision date and are subject to change without notice.

JOHNSON CONTROLS
17 MARY MULLER DRIVE
P.O. BOX 19545
CHRISTCHURCH, PH: +64 3 3895096
NEW ZEALAND. FAX: +64 3 3895938

MX1
EXTERNAL ALARM ANC2
WIRING DIAGRAM

DRAWING No: 1982-71 SHEET 121 of N

A3	ISS/REV C	PART No:
-----------	------------------	----------

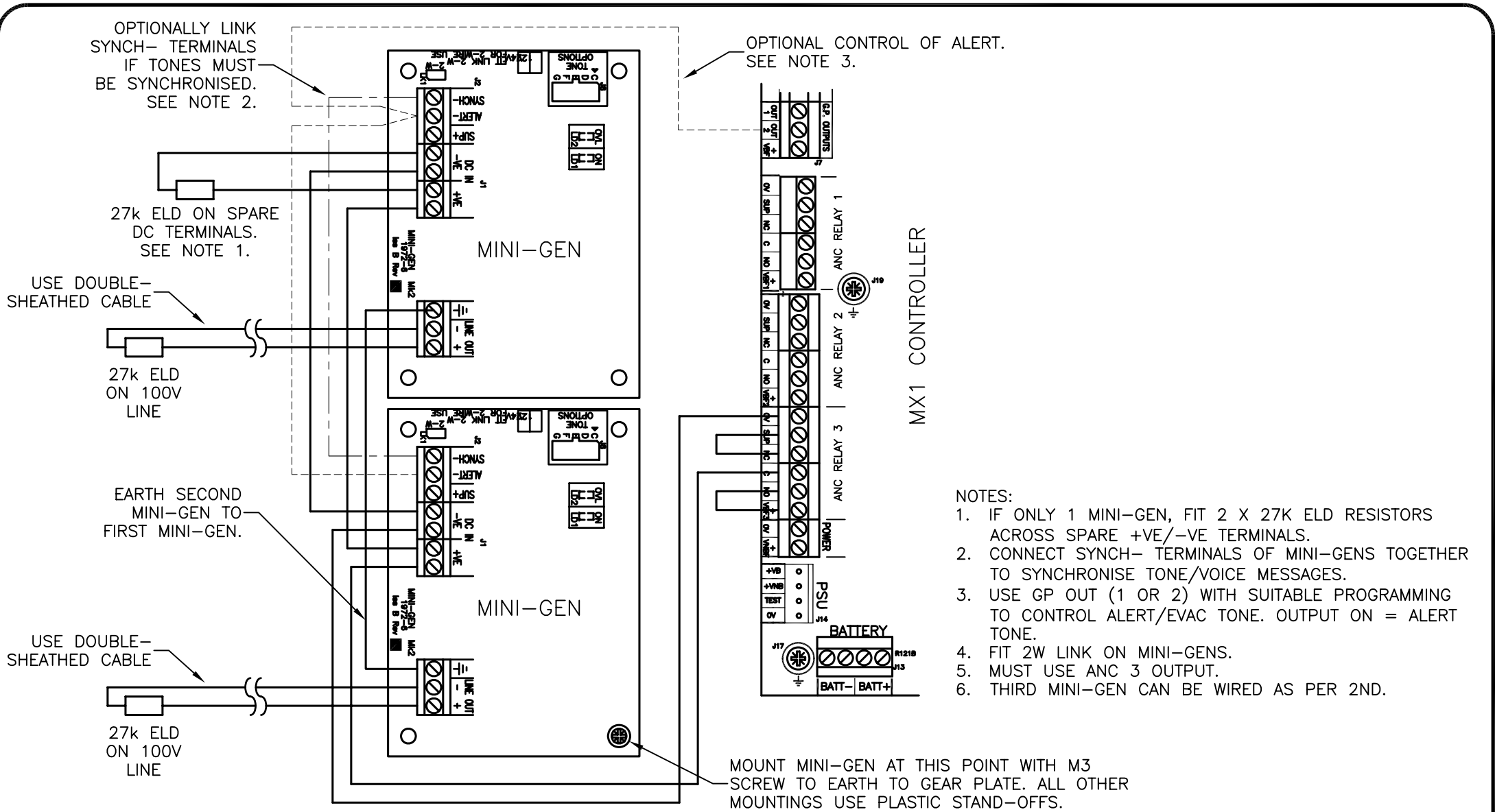

CONFIDENTIAL: THIS DOCUMENT MUST NOT BE COPIED NOR THE CONTENTS PASSED ON TO ANY THIRD PARTY WITHOUT THE CONSENT OF THE COMPANY.

UNLESS OTHERWISE STATED: ALL DIMENSIONS IN MILLIMETRES. DO NOT SCALE. TOLERANCES ARE TO BE: 1 DECIMAL PLACE ±0.5, 2 DECIMAL PLACES ±0.3, 3 DECIMAL PLACES ±0.1

3rd ANGLE PROJECTION

ISS/REV	AMENDMENTS	ECO	DRN	CHKD	AUTH	APVD	DATE
A	ORIGINAL	-	KJS	RAC	RAC	DSCP	11-08-08

tyco / Safety Products

TYCO SAFETY PRODUCTS
 17 MARY MULLER DRIVE
 P.O. BOX 19545
 CHRISTCHURCH, PH: +64 3 3895096
 NEW ZEALAND. FAX: +64 3 3895938

**MX1
MINI-GEN
WIRING DIAGRAM**

DRAWING No: 1982-71 SHEET 122 of N

A3	ISS/REV A	PART No:
----	-----------	----------

OPTIONAL CONNECTION FOR MX1
CONTROL OF ALERT AND EVAC TONES
SEE NOTE 2

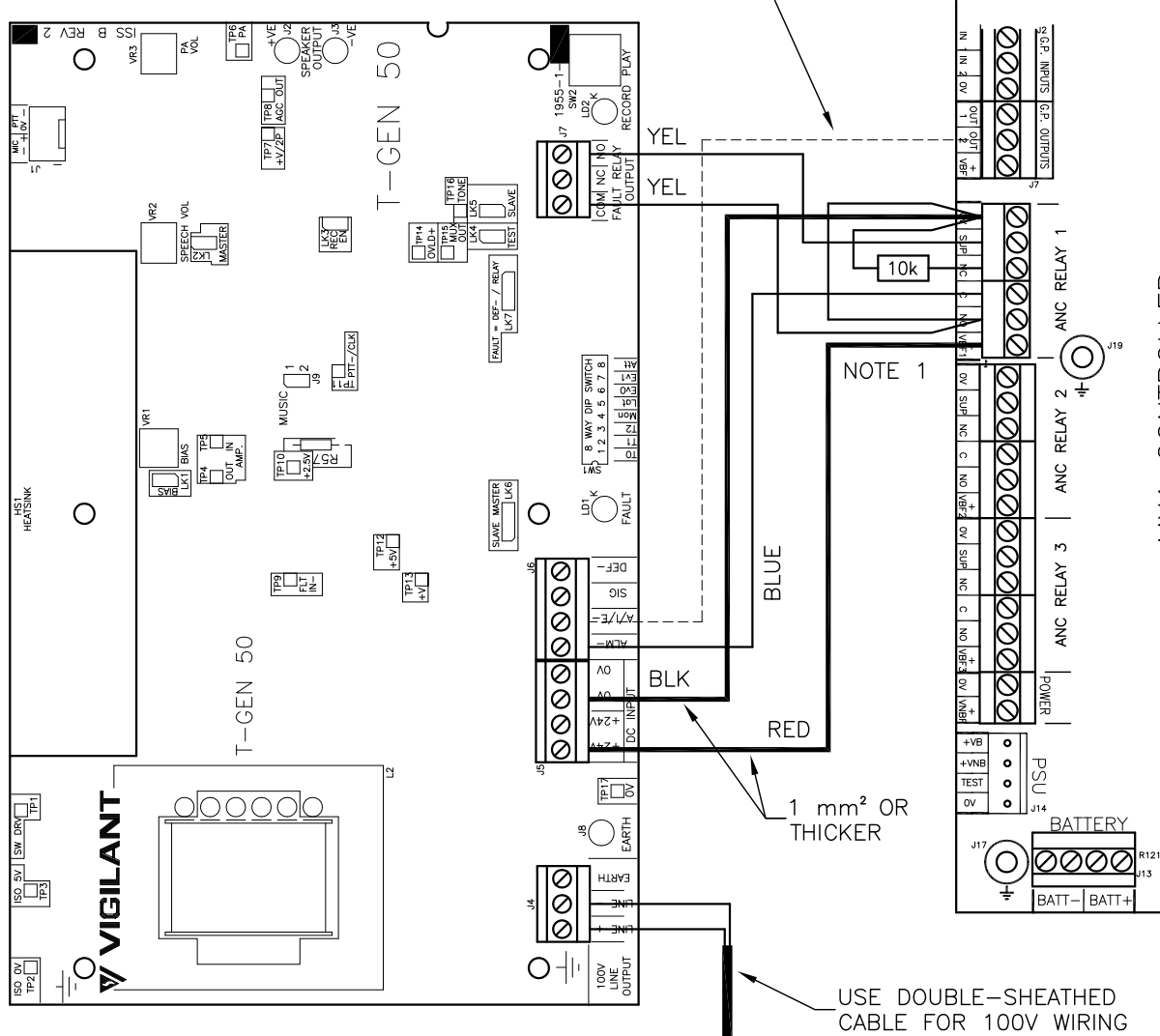

MX1 CONTROLLER

NOTES:

1. USE LM0319 CABLE INCLUDED WITH MX1 FOR WIRING TO T-GEN MOUNTED ON THE GEAR PLATE. USE THE PREFITTED LOOM WHEN FITTING A FP0698 3U T-GEN DOOR.
2. FIT OPTIONAL WIRING FROM GP OUT (1 OR 2) TO CONTROL ALERT/EVAC TONE. OUTPUT ON IS EVAC, WITH T-GEN SET FOR ALERT ONLY TONE (SW1-3 ON). SUPERVISE GP OUTPUT WITH SUITABLE PROFILE, E.G. "TGEN-50 EVAC ACTIVATE"
3. SET T-GEN FOR:
SW1-3 DELAY AS REQUIRED.
SW4 ON
SW5 OFF
SW6-7 TONE AS REQUIRED
SW8 OFF
LK7 IN RELAY POSITION.
4. ANC 2 COULD BE USED WITH T-GEN WITH SAME WIRING (ANC 3 IS NOT DIRECTLY COMPATIBLE WITH T-GEN).

CONFIDENTIAL: THIS DOCUMENT MUST NOT BE COPIED NOR THE CONTENTS PASSED ON TO ANY THIRD PARTY WITHOUT THE CONSENT OF THE COMPANY.

UNLESS OTHERWISE STATED: ALL DIMENSIONS IN MILLIMETRES. DO NOT SCALE. TOLERANCES ARE TO BE: 1 DECIMAL PLACE ±0.5, 2 DECIMAL PLACES ±0.3, 3 DECIMAL PLACES ±0.1

3rd ANGLE PROJECTION

ISS/REV	AMENDMENTS	ECO	DRN	CHKD	AUTH	APVD	DATE
A	ORIGINAL	-	KJS	RAC	RAC	DSCP	8-08-08
B	WIRE COLOURS ADDED, NOTE 1 UPDATED.	4041	KJS	GEL	LSC	DP	29-7-09

tyco / Safety Products
 TYCO SAFETY PRODUCTS
 17 MARY MULLER DRIVE
 P.O. BOX 19545
 CHRISTCHURCH, PH: +64 3 3895096
 NEW ZEALAND. FAX: +64 3 3895938

**MX1
T-GEN 50
WIRING DIAGRAM**

DRAWING No: 1982-71 SHEET 123 of N

A3	ISS/REV B	PART No:	
----	-----------	----------	--

OPTIONALLY LINK SYNCH- TERMINALS
IF STROBES MUST BE SYNCHRONISED.
SEE NOTE 2.

27k ELD ON SPARE
DC TERMINALS.
SEE NOTE 1.

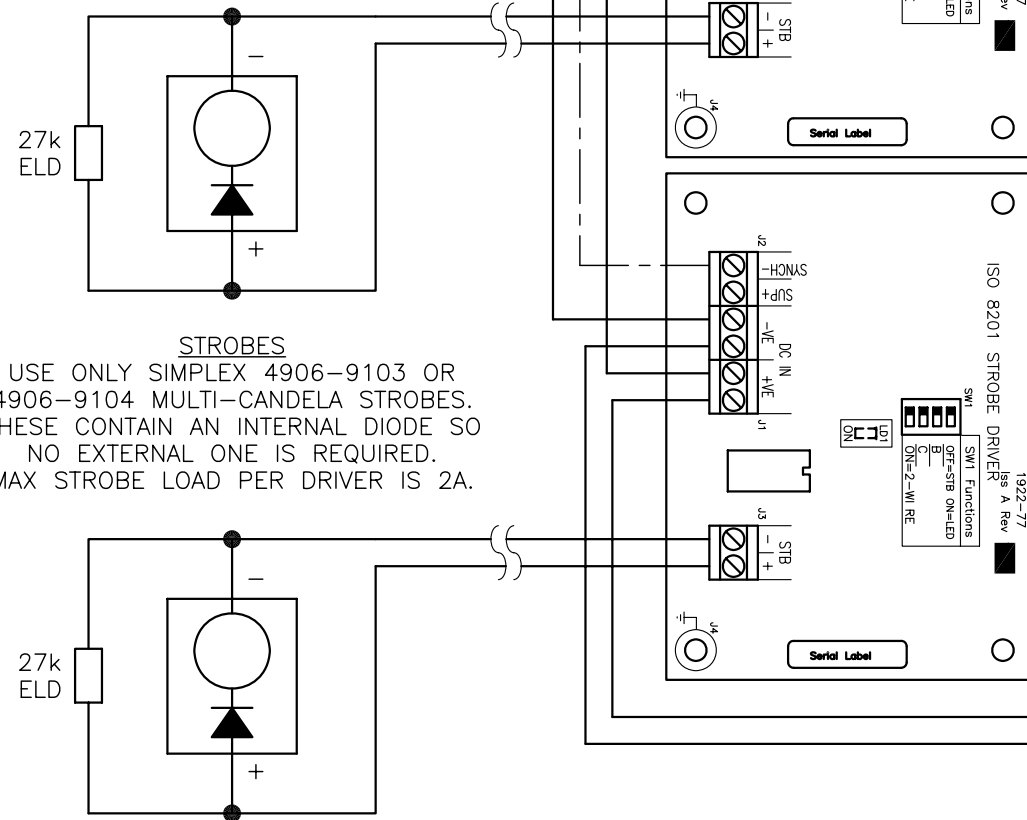

STROBES

USE ONLY SIMPLEX 4906-9103 OR
4906-9104 MULTI-CANDELA STROBES.
THESE CONTAIN AN INTERNAL DIODE SO
NO EXTERNAL ONE IS REQUIRED.
MAX STROBE LOAD PER DRIVER IS 2A.

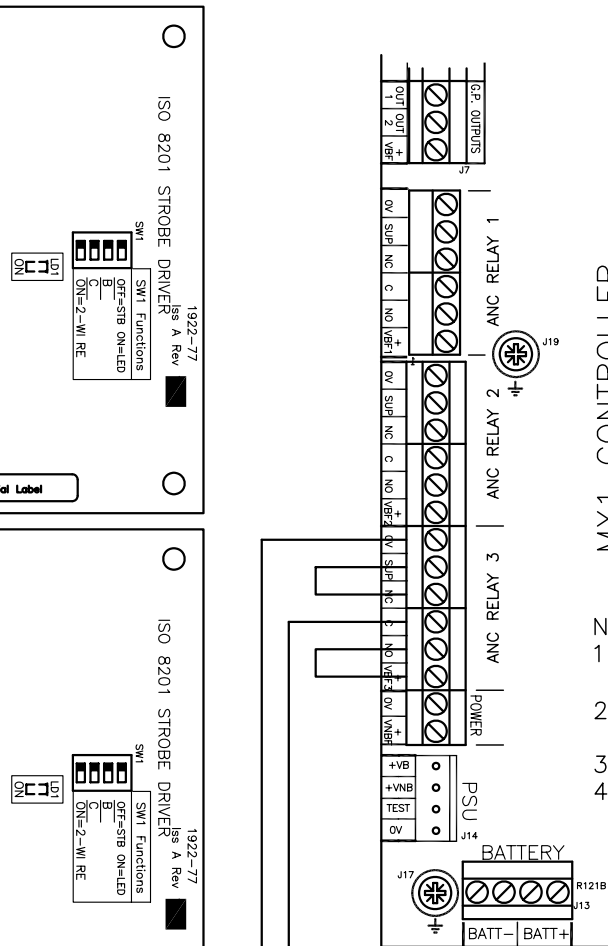

MX1 CONTROLLER

NOTES:

1. IF ONLY 1 STROBE DRIVER, FIT 2 X 27K ELD RESISTORS ACROSS SPARE +VE/-VE TERMINALS.
2. CONNECT SYNCH- TERMINALS OF STROBE DRIVERS TOGETHER TO SYNCHRONISE FLASHING.
3. TURN ON 2 WIRE SWITCH ON STROBE DRIVER.
4. MUST USE ANC 3 OUTPUT.

CONFIDENTIAL: THIS DOCUMENT MUST NOT BE COPIED NOR THE CONTENTS PASSED ON TO ANY THIRD PARTY WITHOUT THE CONSENT OF THE COMPANY.

UNLESS OTHERWISE STATED: ALL DIMENSIONS IN MILLIMETRES. DO NOT SCALE. TOLERANCES ARE TO BE: 1 DECIMAL PLACE ±0.5, 2 DECIMAL PLACES ±0.3, 3 DECIMAL PLACES ±0.1

3rd ANGLE PROJECTION

ISS/REV	AMENDMENTS	ECO	DRN	CHKD	AUTH	APVD	DATE
A	ORIGINAL	-	KJS	RAC	RAC	DSCP	12-08-08
B	EARTHING NOTE DELETED.	4167	KJS	LSC	RC	DP	13-9-10

tyco / Safety Products
 TYCO SAFETY PRODUCTS
 17 MARY MULLER DRIVE
 P.O. BOX 19545
 CHRISTCHURCH, PH: +64 3 3895096
 NEW ZEALAND. FAX: +64 3 3895938

MX1
ISO 8201 STROBE DRIVER
WIRING DIAGRAM

DRAWING No: 1982-71 SHEET 124 of N

A3	ISS/REV B	PART No:	
----	-----------	----------	--

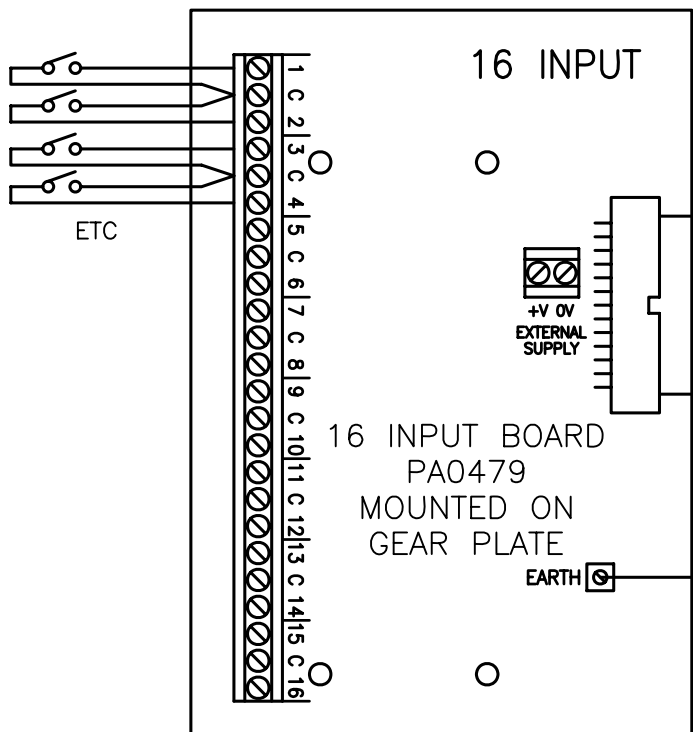
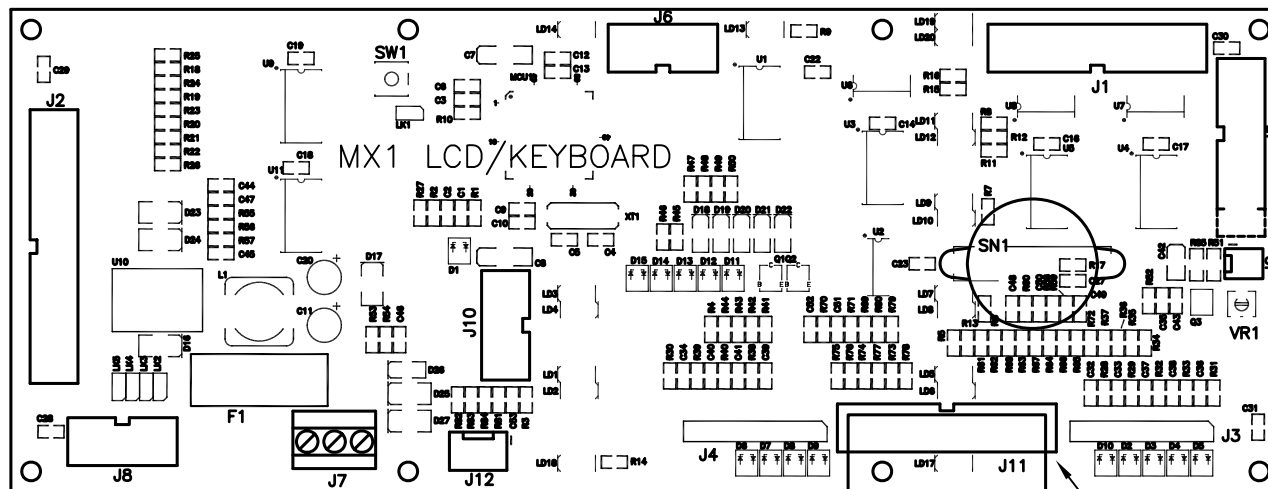

26 WAY FRC

GP SWITCH INPUTS

NOTES:

1. INPUTS:
CLEAN CONTACT, NO EOL.
OR COMMON WITH MX1 0V.
2. PA0483 UNPROTECTED TERMINATION BOARD CAN ALTERNATIVELY BE USED FOR PANEL INTERNAL WIRING. WIRE CLEAN CONTACT BETWEEN INPUT AND COMMON 0V.

CONFIDENTIAL: THIS DOCUMENT MUST NOT BE COPIED NOR THE CONTENTS PASSED ON TO ANY THIRD PARTY WITHOUT THE CONSENT OF THE COMPANY.

UNLESS OTHERWISE STATED: ALL DIMENSIONS IN MILLIMETRES. DO NOT SCALE. TOLERANCES ARE TO BE: 1 DECIMAL PLACE ±0.5, 2 DECIMAL PLACES ±0.3, 3 DECIMAL PLACES ±0.1

3rd ANGLE PROJECTION

ISS/REV	AMENDMENTS	ECO	DRN	CHKD	AUTH	APVD	DATE
A	ORIGINAL	-	KJS	RAC	RAC	DSCP	12-08-08

tyco / Safety Products

TYCO SAFETY PRODUCTS
17 MARY MULLER DRIVE
P.O. BOX 19545
CHRISTCHURCH, PH: +64 3 3895096
NEW ZEALAND. FAX: +64 3 3895938

MX1
16 WAY PROTECTED I/P BOARD
WIRING DIAGRAM

DRAWING No: 1982-71 SHEET 125 of N

A3	ISS/REV A	PART No:
----	-----------	----------

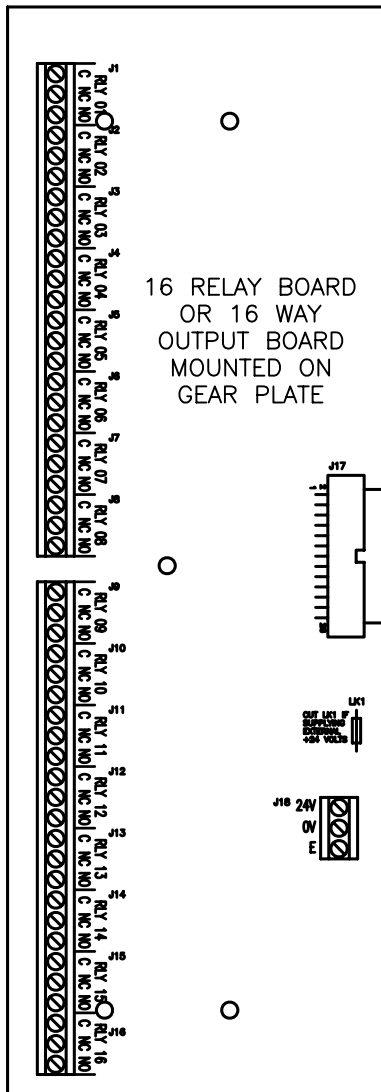

16 RELAY BOARD
OR 16 WAY
OUTPUT BOARD
MOUNTED ON
GEAR PLATE

NOTES:

- 16 RELAY OUTPUTS:
RELAY = SINGLE POLE CHANGE-OVER
2A 30VDC. USE PA0470.
- ALTERNATIVELY 16 OPEN COLLECTOR OUTPUTS:
OPEN COLLECTOR = 50mA OPEN COLLECTOR
PULL DOWN TO <1V. MX1 +VB VOLTAGE MAX.
WIRING MUST NOT EXIT CABINET. USE PA0483
UNPROTECTED TERMINATION BOARD OR PA0480
16 WAY PROTECTED OUTPUT BOARD.

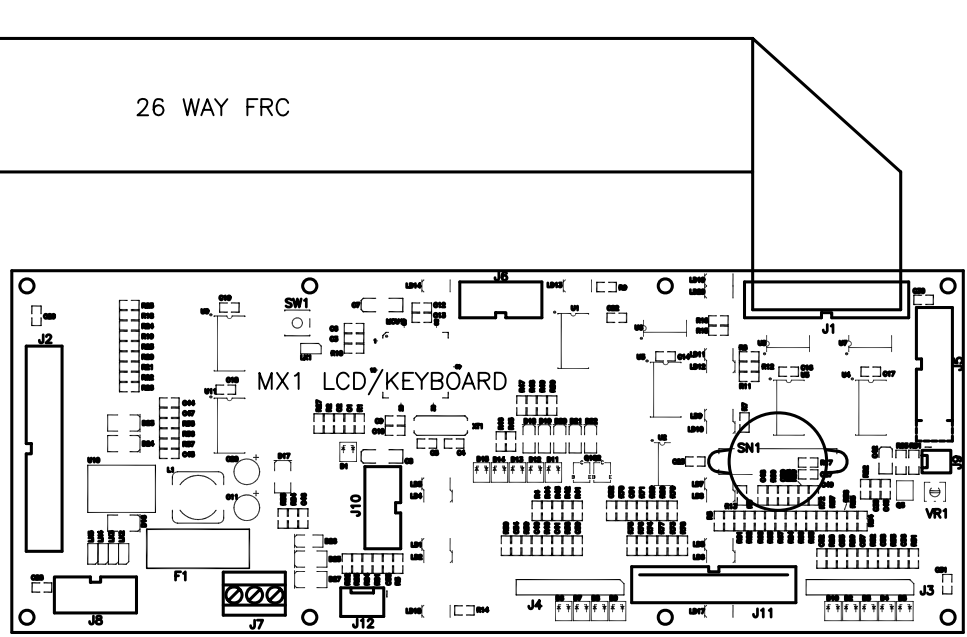

CONFIDENTIAL: THIS DOCUMENT MUST NOT BE COPIED NOR THE CONTENTS PASSED ON TO ANY THIRD PARTY WITHOUT THE CONSENT OF THE COMPANY.

UNLESS OTHERWISE STATED: ALL DIMENSIONS IN MILLIMETRES. DO NOT SCALE. TOLERANCES ARE TO BE: 1 DECIMAL PLACE ±0.5, 2 DECIMAL PLACES ±0.3, 3 DECIMAL PLACES ±0.1

3rd ANGLE PROJECTION

ISS/REV	AMENDMENTS	ECO	DRN	CHKD	AUTH	APVD	DATE
A	ORIGINAL	-	KJS	RAC	RAC	DSCP	12-08-08

tyco / Safety Products
 TYCO SAFETY PRODUCTS
 17 MARY MULLER DRIVE
 P.O. BOX 19545
 CHRISTCHURCH, PH: +64 3 3895096
 NEW ZEALAND. FAX: +64 3 3895938

MX1
16 WAY RELAY OR O/C BOARD
WIRING DIAGRAM

DRAWING No: 1982-71 SHEET 126 of N

A3	ISS/REV A	PART No:
----	-----------	----------

QE90

MX1

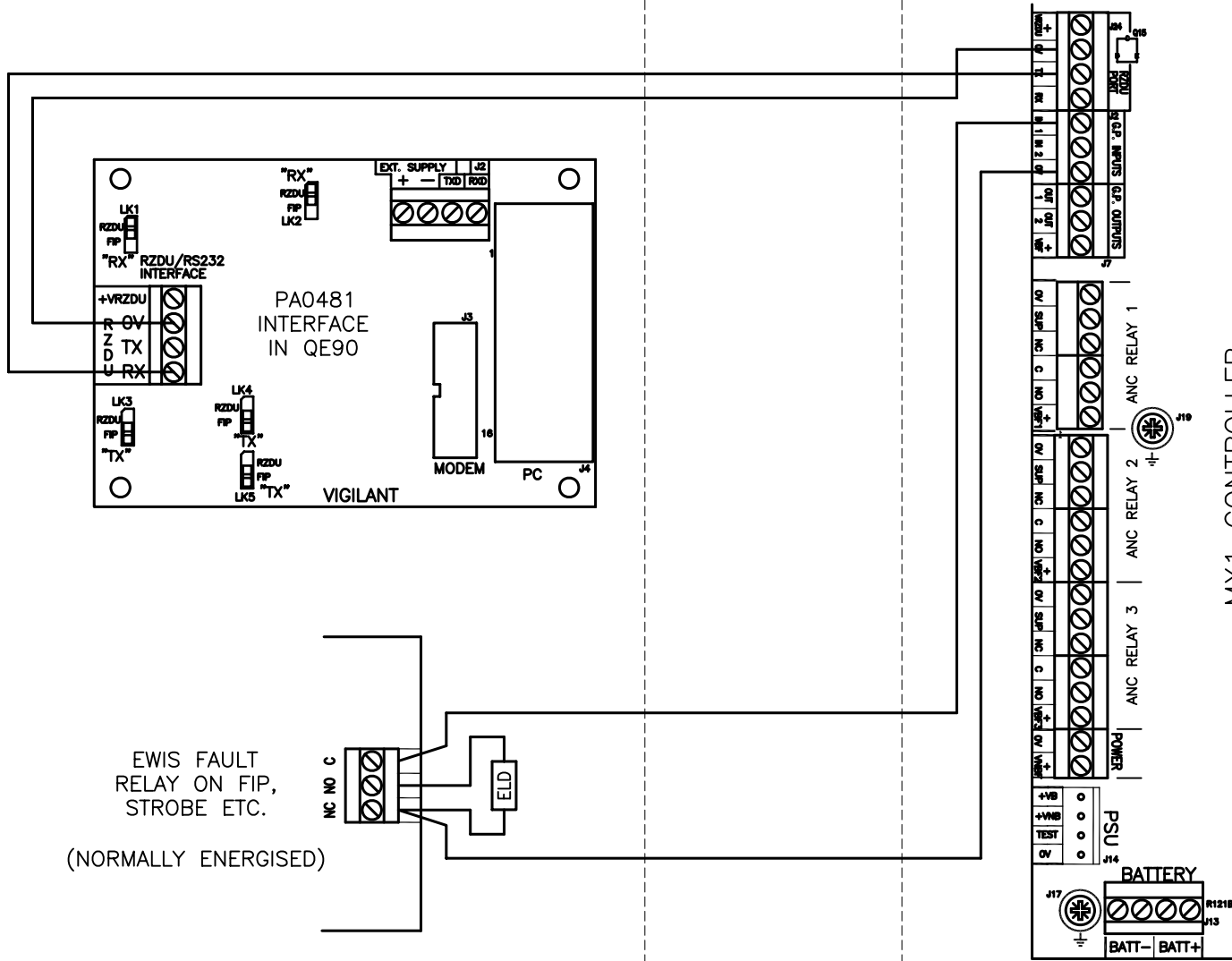

MX1 CONTROLLER

NOTES:

1. REFER TO LT0088 QE90 INSTALLATION MANUAL FOR QE90 WIRING.
2. USE GP1 OR 2 INPUT.

CONFIDENTIAL: THIS DOCUMENT MUST NOT BE COPIED NOR THE CONTENTS PASSED ON TO ANY THIRD PARTY WITHOUT THE CONSENT OF THE COMPANY.

UNLESS OTHERWISE STATED: ALL DIMENSIONS IN MILLIMETRES. DO NOT SCALE. TOLERANCES ARE TO BE: 1 DECIMAL PLACE ±0.5, 2 DECIMAL PLACES ±0.3, 3 DECIMAL PLACES ±0.1

3rd ANGLE PROJECTION

ISS/REV	AMENDMENTS	ECO	DRN	CHKD	AUTH	APVD	DATE
A	ORIGINAL	-	KJS	RAC	RAC	DSCP	12-08-08

tyco / Safety Products
 TYCO SAFETY PRODUCTS
 17 MARY MULLER DRIVE
 P.O. BOX 19545
 CHRISTCHURCH, PH: +64 3 3895096
 NEW ZEALAND. FAX: +64 3 3895938

MX1
QE90 'RZDU' I / F
WIRING DIAGRAM

DRAWING No: 1982-71 SHEET 127 of N

A3	ISS/REV A	PART No:
----	-----------	----------

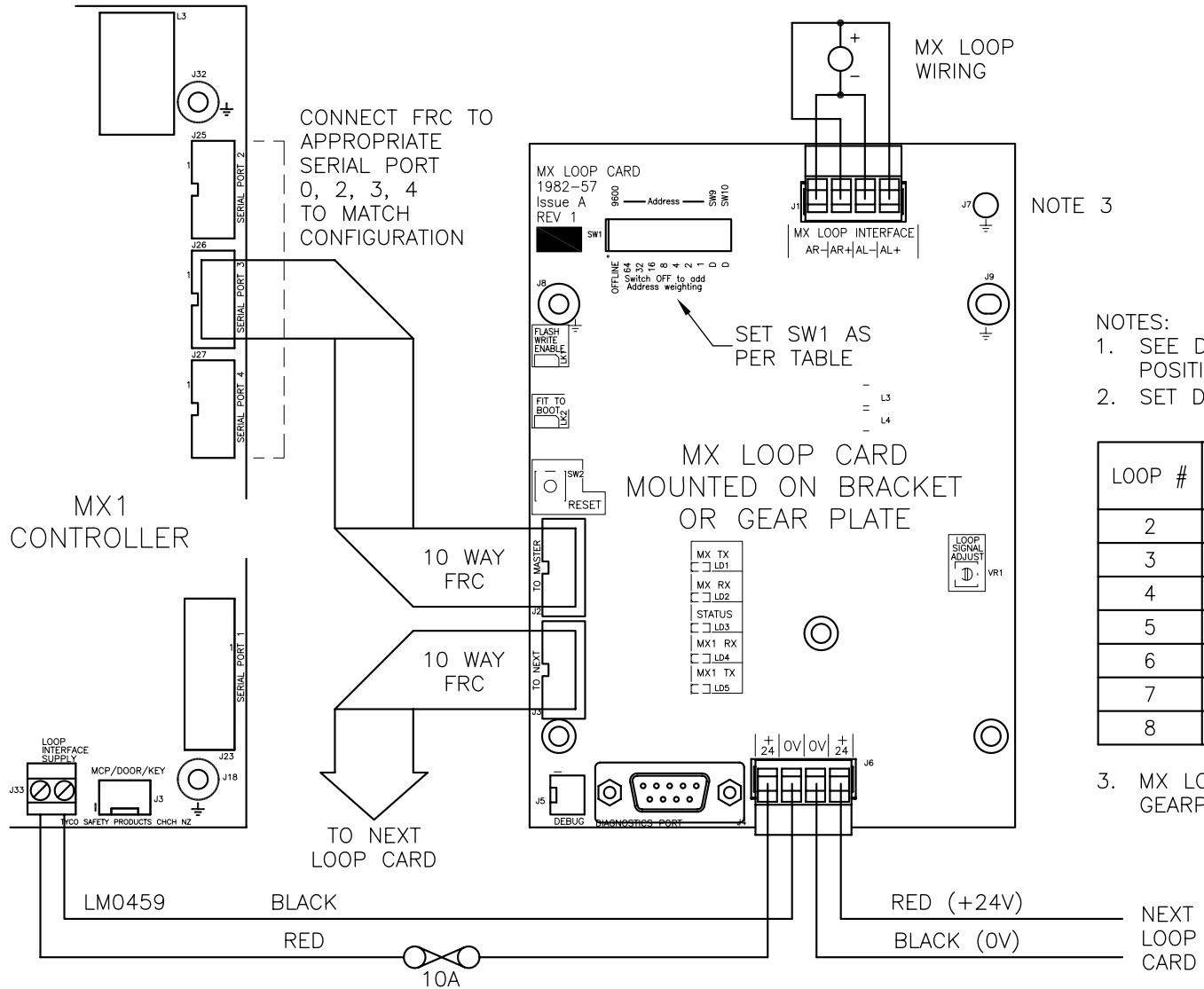

- NOTES:
- SEE DRAWINGS 1982-71 SHEET 140, 142 OR 143 FOR AVAILABLE POSITIONS ON GEARPLATE.
 - SET DIP SWITCH FOR LOOP #.

LOOP #	OFFLINE /9600	64	32	16	8	4	2	1	SW9	SW10
2	ON	ON	ON	ON	ON	ON	OFF	ON	ON	ON
3	ON	ON	ON	ON	ON	ON	OFF	OFF	ON	ON
4	ON	ON	ON	ON	ON	OFF	ON	ON	ON	ON
5	ON	ON	ON	ON	ON	OFF	ON	OFF	ON	ON
6	ON	ON	ON	ON	ON	OFF	OFF	ON	ON	ON
7	ON	ON	ON	ON	ON	OFF	OFF	OFF	ON	ON
8	ON	ON	ON	ON	OFF	ON	ON	ON	ON	ON

- MX LOOP CARD MUST BE EARTHED VIA MOUNTING OR J7 TO GEARPLATE.

CONFIDENTIAL: THIS DOCUMENT MUST NOT BE COPIED NOR THE CONTENTS PASSED ON TO ANY THIRD PARTY WITHOUT THE CONSENT OF THE COMPANY.

UNLESS OTHERWISE STATED: ALL DIMENSIONS IN MILLIMETRES. DO NOT SCALE. TOLERANCES ARE TO BE: 1 DECIMAL PLACE ±0.5, 2 DECIMAL PLACES ±0.3, 3 DECIMAL PLACES ±0.1

3rd ANGLE PROJECTION

ISS/REV	AMENDMENTS	ECO	DRN	CHKD	AUTH	APVD	DATE
A	ORIGINAL	-	KJS	RAC	RAC	DSCP	12-08-08
B	NOTES UPDATED. TABLE ADDED. DETAIL ADDED.	4167	KJS	LSC	DP	RC	13-9-10
C	NOTE 1 CHANGED.	ECS1604	KJS	RC	RC	DP	22-11-11

tyco
Fire Protection Products

TYCO FIRE PROTECTION PRODUCTS
17 MARY MULLER DRIVE
P.O. BOX 19545
CHRISTCHURCH, PH: +64 3 3895096
NEW ZEALAND. FAX: +64 3 3895938

MX1
LOOP CARD
WIRING DIAGRAM

DRAWING No: 1982-71 SHEET 128 of N

A3 ISS/REV C PART No:

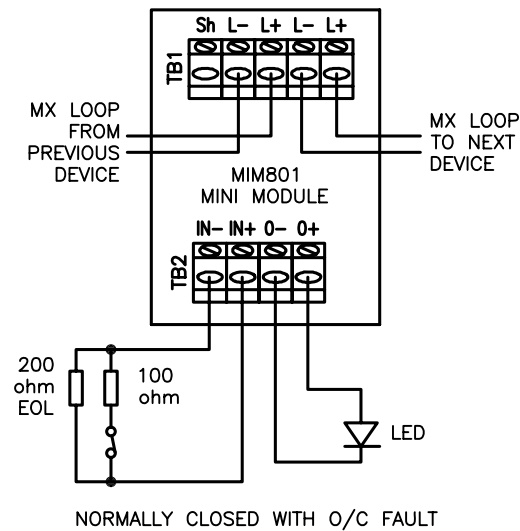
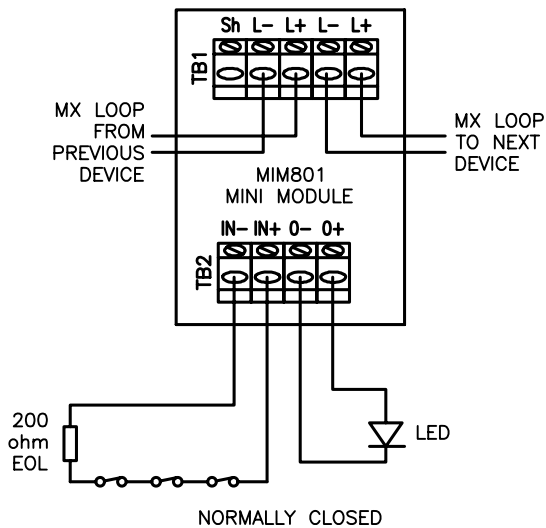
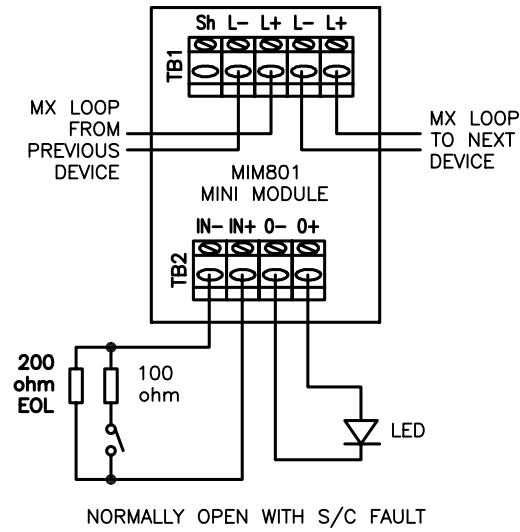
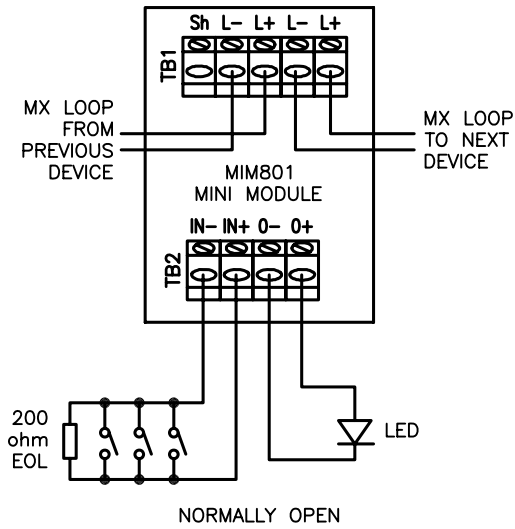

NOTES:

1. INPUT CONTACTS MUST BE VOLTAGE FREE.
2. CIRCUIT RESISTANCE: 10 OHM MAX.
3. CIRCUIT LENGTH: 10m MAX.
4. LED CURRENT: 2.5mA.
5. NORMALLY OPEN MODES DO NOT SUPPORT INTERRUPT.
6. MIM801 USED IN NZ ONLY.

CONFIDENTIAL: THIS DOCUMENT MUST NOT BE COPIED NOR THE CONTENTS PASSED ON TO ANY THIRD PARTY WITHOUT THE CONSENT OF THE COMPANY.

UNLESS OTHERWISE STATED: ALL DIMENSIONS IN MILLIMETRES. DO NOT SCALE. TOLERANCES ARE TO BE: 1 DECIMAL PLACE ± 0.5 , 2 DECIMAL PLACES ± 0.3 , 3 DECIMAL PLACES ± 0.1

3rd ANGLE PROJECTION

ISS/REV	AMENDMENTS	ECO	DRN	CHKD	AUTH	APVD	DATE
A	ORIGINAL	-	KJS	RAC	RAC	DSCP	8-8-08

tyco / Safety Products

TYCO SAFETY PRODUCTS
 17 MARY MULLER DRIVE
 P.O. BOX 19545
 CHRISTCHURCH, PH: +64 3 3895096
 NEW ZEALAND. FAX: +64 3 3895938

MX1
MIM801 MINI INPUT MODULE
WIRING DIAGRAM

DRAWING No: 1982-71 SHEET 129 of N

A3	ISS/REV A	PART No:	
----	-----------	----------	--

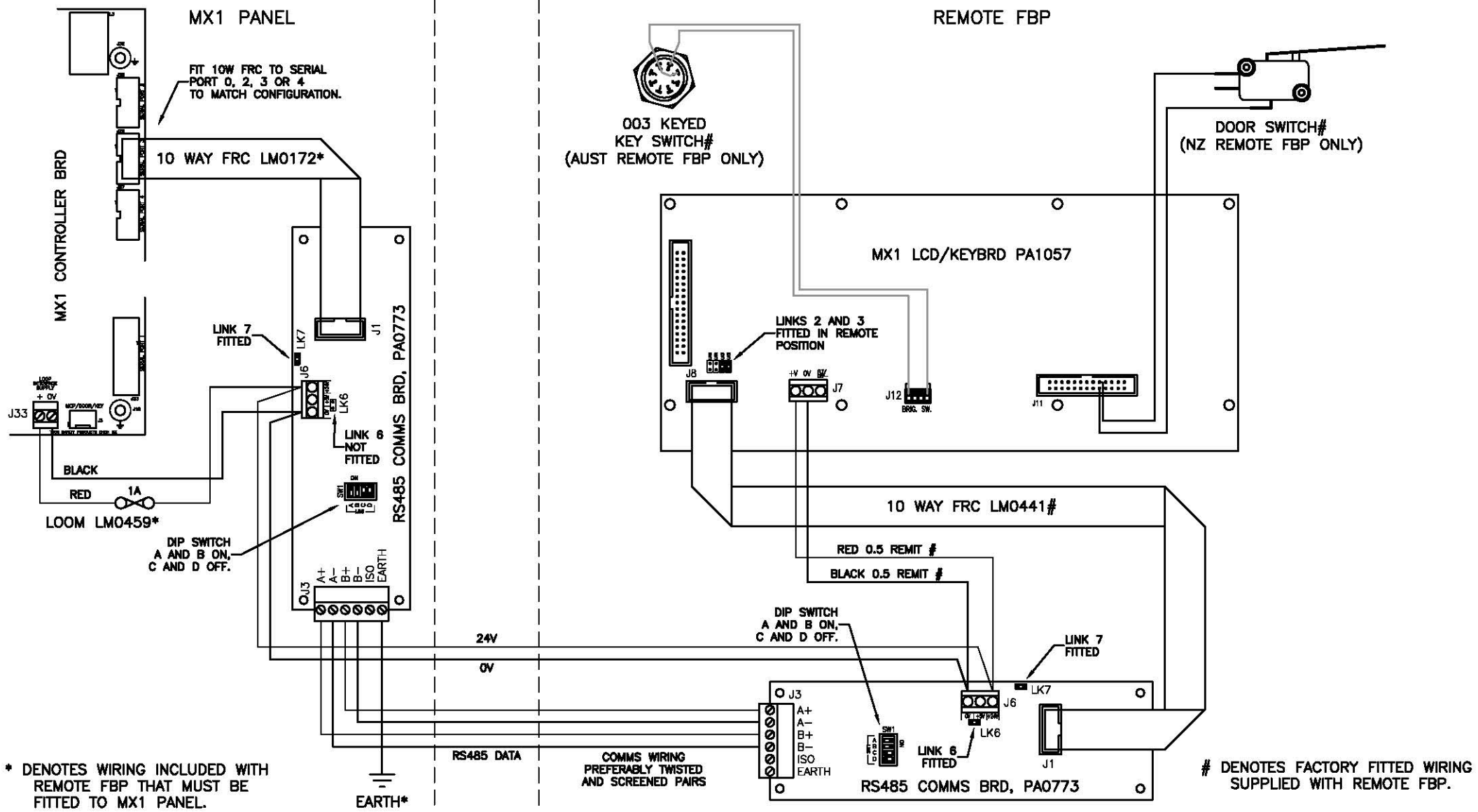

* DENOTES WIRING INCLUDED WITH REMOTE FBP THAT MUST BE FITTED TO MX1 PANEL.

CONFIDENTIAL: THIS DOCUMENT MUST NOT BE COPIED NOR THE CONTENTS PASSED ON TO ANY THIRD PARTY WITHOUT THE CONSENT OF THE COMPANY.

UNLESS OTHERWISE STATED: ALL DIMENSIONS IN MILLIMETRES. DO NOT SCALE. TOLERANCES ARE TO BE: 1 DECIMAL PLACE ±0.5, 2 DECIMAL PLACES ±0.3, 3 DECIMAL PLACES ±0.1

3rd ANGLE PROJECTION

ISS/REV	AMENDMENTS	ECO	DRN	CHKD	AUTH	APVD	DATE
A	ORIGNAL	-	KJS	YZH	RC	DP	18-8-10
B	KEY SWITCH WIRING UPDATED.	4222	KJS	YZH	RC	DP	8-12-10
C	NZ DOOR SWITCH WIRING ADDED FOR FP1008.	4532	KJS	RC	RC	DP	18-7-11

tyco
 Fire Protection Products
 TYCO FIRE PROTECTION PRODUCTS
 17 MARY MULLER DRIVE
 P.O. BOX 19545
 CHRISTCHURCH, PH: +64 3 3895096
 NEW ZEALAND. FAX: +64 3 3895938

**MX1
 REMOTE FBP
 WIRING DIAGRAM**

DRAWING No: 1982-71 SHEET 130 of N

A3	ISS/REV	C	PART No:
----	---------	---	----------

MX1 CONTROLLER

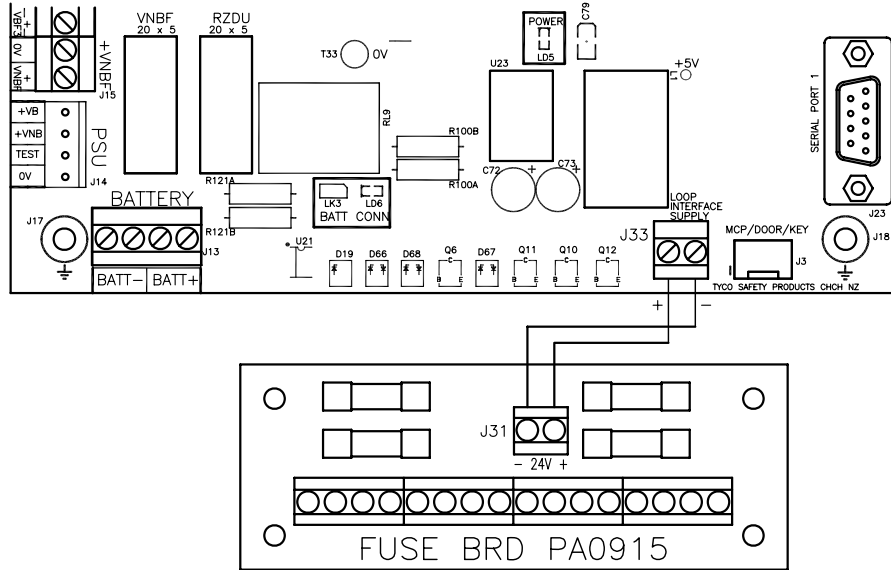

NOTES:

1. MOUNT FUSE BOARD USING 4 PLASTIC DOUBLE BARB PCB STAND-OFFS (HW0052) FITTED FROM FRONT OF GEAR PLATE.
2. FUSE 1A WIRING AS STANDARD. CAN BE REPLACED UP TO 3A.
3. MAX COMBINED LOAD DETERMINED BY PSU/BATTERY RATING.

CONFIDENTIAL: THIS DOCUMENT MUST NOT BE COPIED NOR THE CONTENTS PASSED ON TO ANY THIRD PARTY WITHOUT THE CONSENT OF THE COMPANY.

UNLESS OTHERWISE STATED: ALL DIMENSIONS IN MILLIMETRES. DO NOT SCALE. TOLERANCES ARE TO BE: 1 DECIMAL PLACE ± 0.5 , 2 DECIMAL PLACES ± 0.3 , 3 DECIMAL PLACES ± 0.1

3rd ANGLE PROJECTION

ISS/REV	AMENDMENTS	ECO	DRN	CHKD	AUTH	APVD	DATE
A	ORIGINAL	4167	KJS	LSC	RC	DP	13-9-10

tyco / Safety Products

TYCO SAFETY PRODUCTS
17 MARY MULLER DRIVE
P.O. BOX 19545
CHRISTCHURCH, PH: +64 3 3895096
NEW ZEALAND. FAX: +64 3 3895938

**MX1
PA0915 FUSE BOARD
WIRING DIAGRAM**

DRAWING No: 1982-71 SHEET 131 of N

A3 | ISS/REV A | PART No: 4100 - KT0448

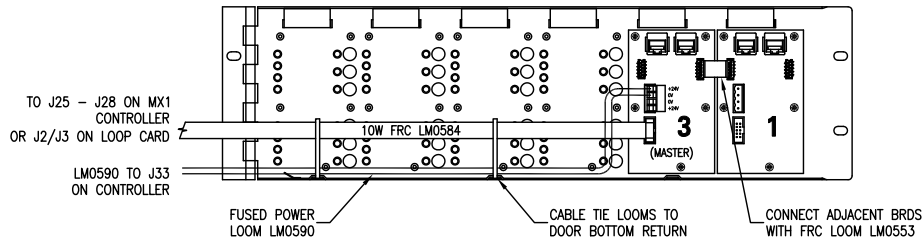

EXAMPLE 2
DOOR WITH 2 CONTROL BOARDS FITTED

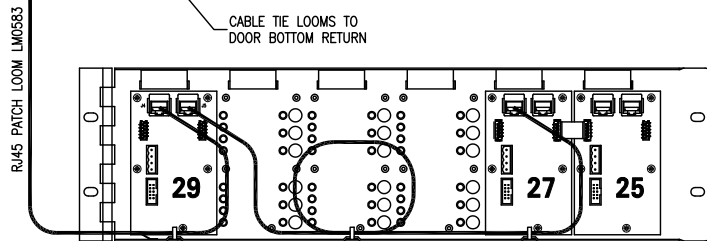
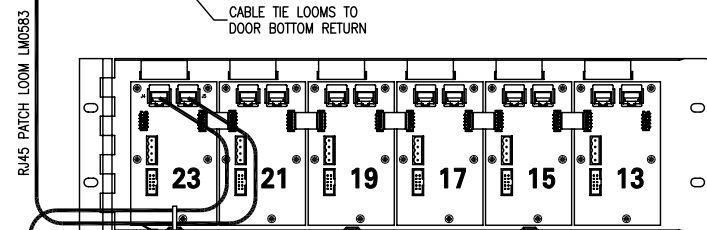
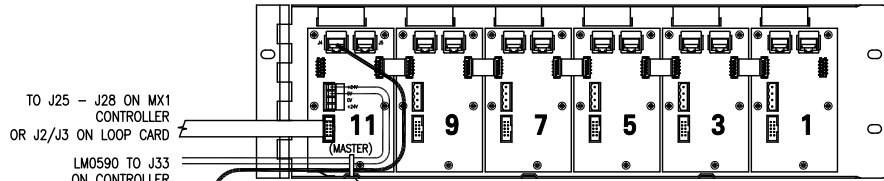

EXAMPLE 3
3 DOORS WITH 15 CONTROL BOARDS FITTED

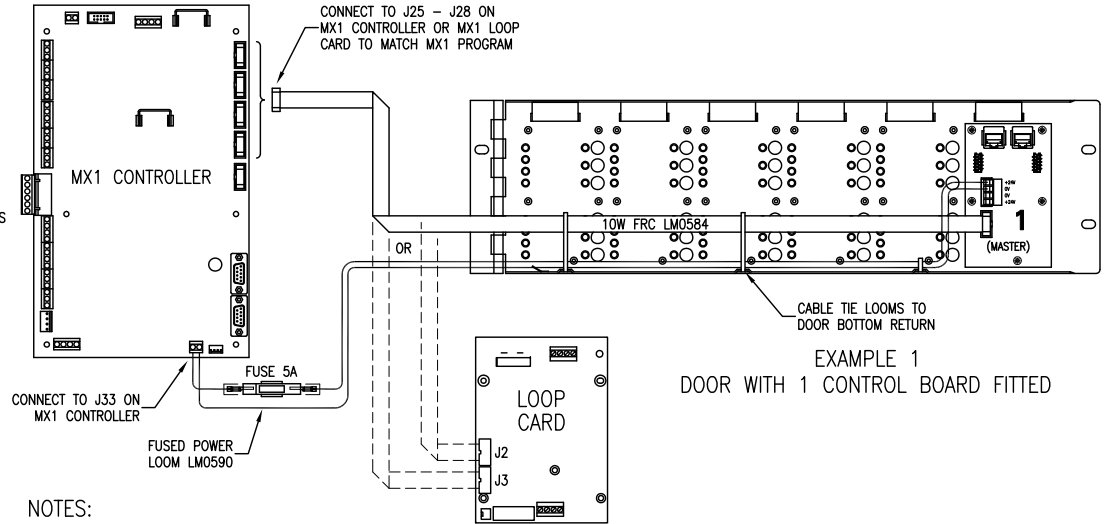

EXAMPLE 1
DOOR WITH 1 CONTROL BOARD FITTED

NOTES:

1. DIAGRAMS SHOW CONNECTIONS AND SUGGESTED LOOMS FOR THREE EXAMPLE ARRANGEMENTS OF MX1 3U AS1668 FAN CONTROL DOORS AND BOARDS.
2. USE THESE DIAGRAMS AS A GUIDE FOR OTHER QUANTITIES AND ARRANGEMENTS OF AS1668 FAN CONTROL DOORS AND CONTROL BOARDS.
3. EACH CONTROL BOARD NEEDS UNIQUE ODD NUMBER SET ON DIP SWITCH TO ASSIGN TOP FAN CONTROL NUMBER TO MATCH CONFIGURATION.
4. USE 10 WAY FRC LOOM LM0553 TO CONNECT ADJACENT BOARDS ON THE SAME DOOR, OR RJ45 LEAD LM0585 TO CONNECT NON-ADJACENT BOARDS.
5. IF USING ONE OR MORE ADDITIONAL AS1668 FAN CONTROL DOORS: RJ45 PATCH LOOM LM0583 CONNECTS J4/J5 ON A BOARD ON ONE DOOR TO J4/J5 ON A BOARD ON THE NEXT DOOR.
6. 10W FRC LOOM LM0584 CONNECTS THE TOP MOST CONTROL BOARD, CLOSEST TO THE DOOR HINGE, TO J25, J26, J27 OR J28 ON THE MX1 CONTROLLER, OR J2, J3 ON AN MX LOOP CARD TO MATCH MX1 PROGRAMMING. THIS BOARD HAS DIP SWITCH CONFIGURED AS MASTER (ALL OTHERS CONFIGURED AS SLAVE).
7. TO POWER THE CONTROL BOARDS, USE LM0590 TO CONNECT J33 ON THE MX1 CONTROLLER TO J3 ON ONE FAN CONTROL BOARD.

CONFIDENTIAL: THIS DOCUMENT MUST NOT BE COPIED NOR THE CONTENTS PASSED ON TO ANY THIRD PARTY WITHOUT THE CONSENT OF THE COMPANY.

UNLESS OTHERWISE STATED: ALL DIMENSIONS IN MILLIMETRES. DO NOT SCALE. TOLERANCES ARE TO BE: 1 DECIMAL PLACE ±0.5, 2 DECIMAL PLACES ±0.3, 3 DECIMAL PLACES ±0.1

3rd ANGLE PROJECTION

ISS/REV	AMENDMENTS	ECO	DRN	CHKD	AUTH	APVD	DATE
A	ORIGINAL	-	KJS	MH	RC	DP	4-8-14

tyco
Fire Protection Products

TYCO FIRE PROTECTION PRODUCTS
17 MARY MULLER DRIVE
P.O. BOX 19545
CHRISTCHURCH, PH: +64 3 3895096
NEW ZEALAND. FAX: +64 3 3895938

MX1
AS1668 FAN CONTROLS
WIRING DIAGRAM

DRAWING No: 1982-71 SHEET 132 of N

A3 ISS/REV A PART No:

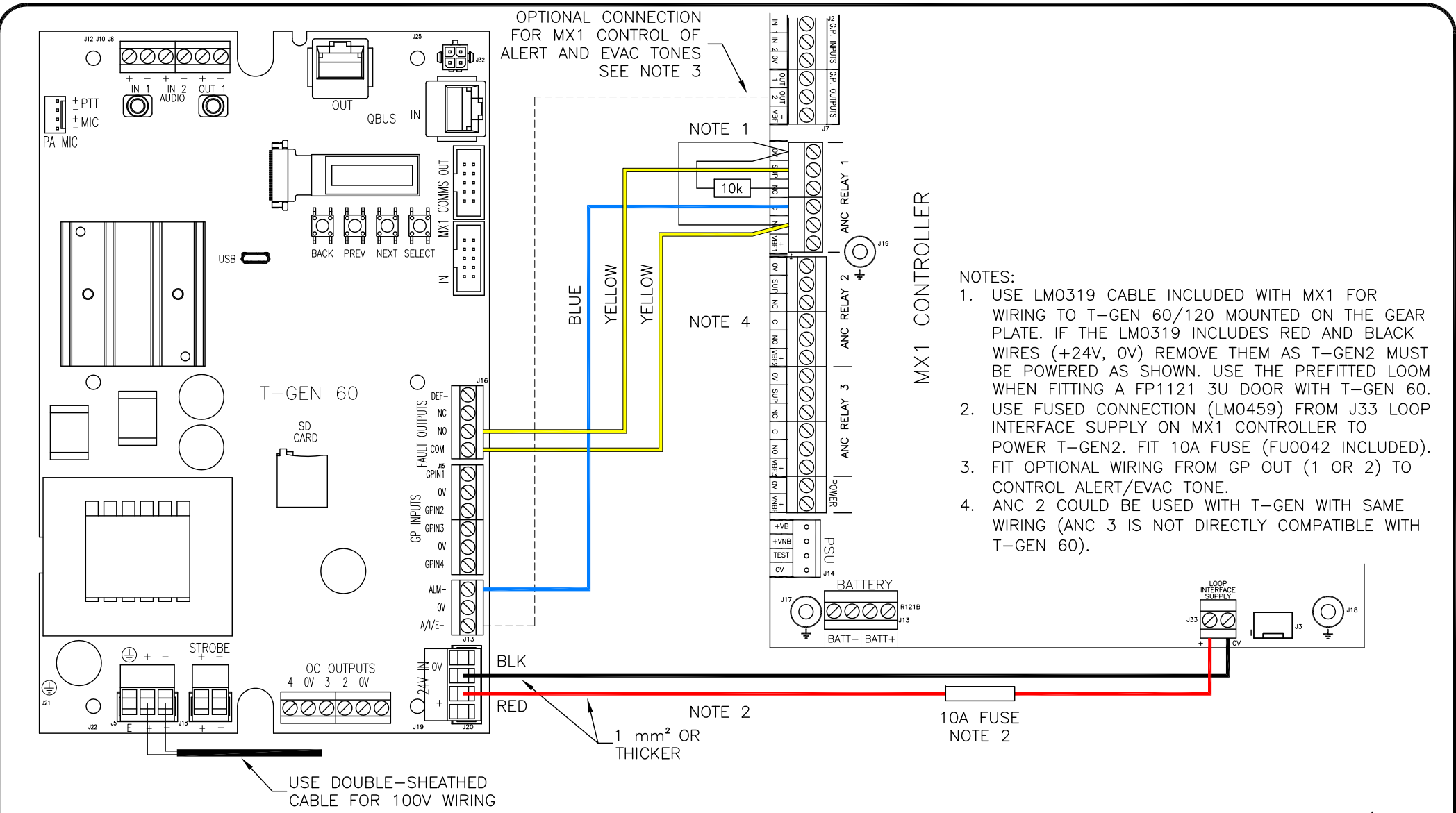

- NOTES:
1. USE LM0319 CABLE INCLUDED WITH MX1 FOR WIRING TO T-GEN 60/120 MOUNTED ON THE GEAR PLATE. IF THE LM0319 INCLUDES RED AND BLACK WIRES (+24V, 0V) REMOVE THEM AS T-GEN2 MUST BE POWERED AS SHOWN. USE THE PREFITTED LOOM WHEN FITTING A FP1121 3U DOOR WITH T-GEN 60.
 2. USE FUSED CONNECTION (LMO459) FROM J33 LOOP INTERFACE SUPPLY ON MX1 CONTROLLER TO POWER T-GEN2. FIT 10A FUSE (FU0042 INCLUDED).
 3. FIT OPTIONAL WIRING FROM GP OUT (1 OR 2) TO CONTROL ALERT/EVAC TONE.
 4. ANC 2 COULD BE USED WITH T-GEN WITH SAME WIRING (ANC 3 IS NOT DIRECTLY COMPATIBLE WITH T-GEN 60).

ISS/REV	AMENDMENTS	ECO	DRN	CHKD	AUTH	APVD	DATE
A	ORIGINAL	5053	KJS	LSC	RC	DC	9-8-17

© 2017 Johnson Controls. All rights reserved. All specifications and other information shown were current as of document revision date and are subject to change without notice.

JOHNSON CONTROLS
 17 MARY MULLER DRIVE
 P.O. BOX 19545
 CHRISTCHURCH, PH: +64 3 3895096
 NEW ZEALAND. FAX: +64 3 3895938

**MX1
T-GEN 60 / 120
WIRING DIAGRAM**

DRAWING No: 1982-71 SHEET 133 of N

A3	ISS/REV A	PART No:
-----------	------------------	----------

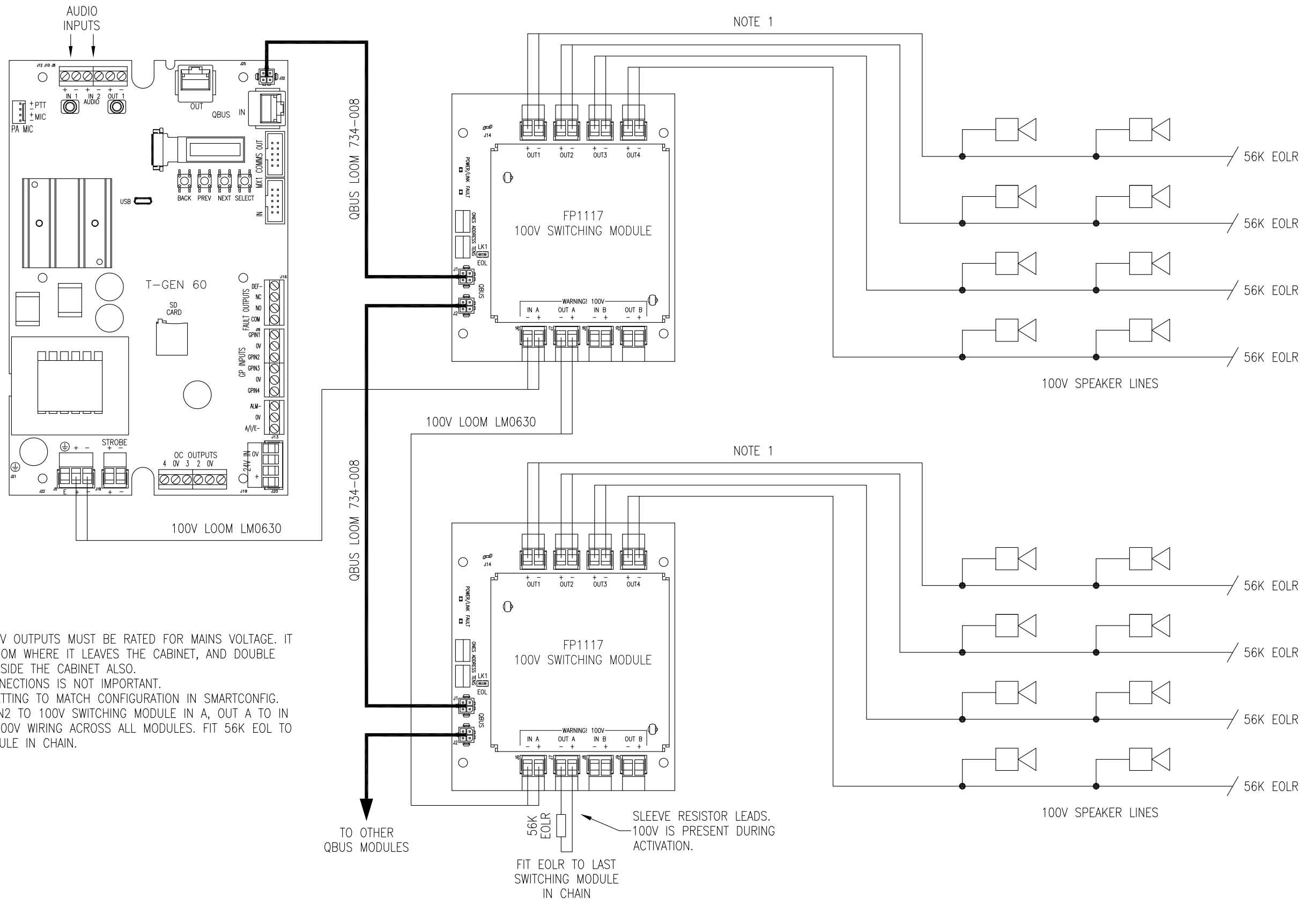

- NOTES:
1. WIRING CONNECTED TO THE 100V OUTPUTS MUST BE RATED FOR MAINS VOLTAGE. IT MUST BE DOUBLE INSULATED FROM WHERE IT LEAVES THE CABINET, AND DOUBLE INSULATION IS RECOMMENDED INSIDE THE CABINET ALSO.
 2. THE ORDER OF QBUS INTERCONNECTIONS IS NOT IMPORTANT.
 3. SWITCHING MODULE ADDRESS SETTING TO MATCH CONFIGURATION IN SMARTCONFIG.
 4. DAISY CHAIN AUDIO FROM T-GEN2 TO 100V SWITCHING MODULE IN A, OUT A TO IN A ETC. MAINTAIN POLARITY OF 100V WIRING ACROSS ALL MODULES. FIT 56K EOLR TO OUT A OF LAST SWITCHING MODULE IN CHAIN.

CONFIDENTIAL: THIS DOCUMENT MUST NOT BE COPIED NOR THE CONTENTS PASSED ON TO ANY THIRD PARTY WITHOUT THE CONSENT OF THE COMPANY.

UNLESS OTHERWISE STATED: ALL DIMENSIONS IN MILLIMETRES. DO NOT SCALE. TOLERANCES ARE TO BE: 1 DECIMAL PLACE ± 0.5 , 2 DECIMAL PLACES ± 0.3 , 3 DECIMAL PLACES ± 0.1

3rd ANGLE PROJECTION

ISS/REV	AMENDMENTS	ECO	DRN	CHKD	AUTH	APVD	DATE
A	ORIGINAL	5022	KJS	LSC	RC	DC	29-8-17
B	UPDATED FOR T-GEN2 GRADE 2.	5142	KJS	PV	RC	DC	15-10-18

© 2017 Johnson Controls. All rights reserved. All specifications and other information shown were current as of document revision date and are subject to change without notice.

JOHNSON CONTROLS
 17 MARY MULLER DRIVE
 P.O. BOX 19545
 CHRISTCHURCH, PH: +64 3 3895096
 NEW ZEALAND. FAX: +64 3 3895938

T-GEN2 SINGLE 100V SWITCHING MODULE WIRING DIAGRAM

DRAWING No: **1982-71** SHEET **134** of **N**

A3 | ISS/REV **B** | PART No:

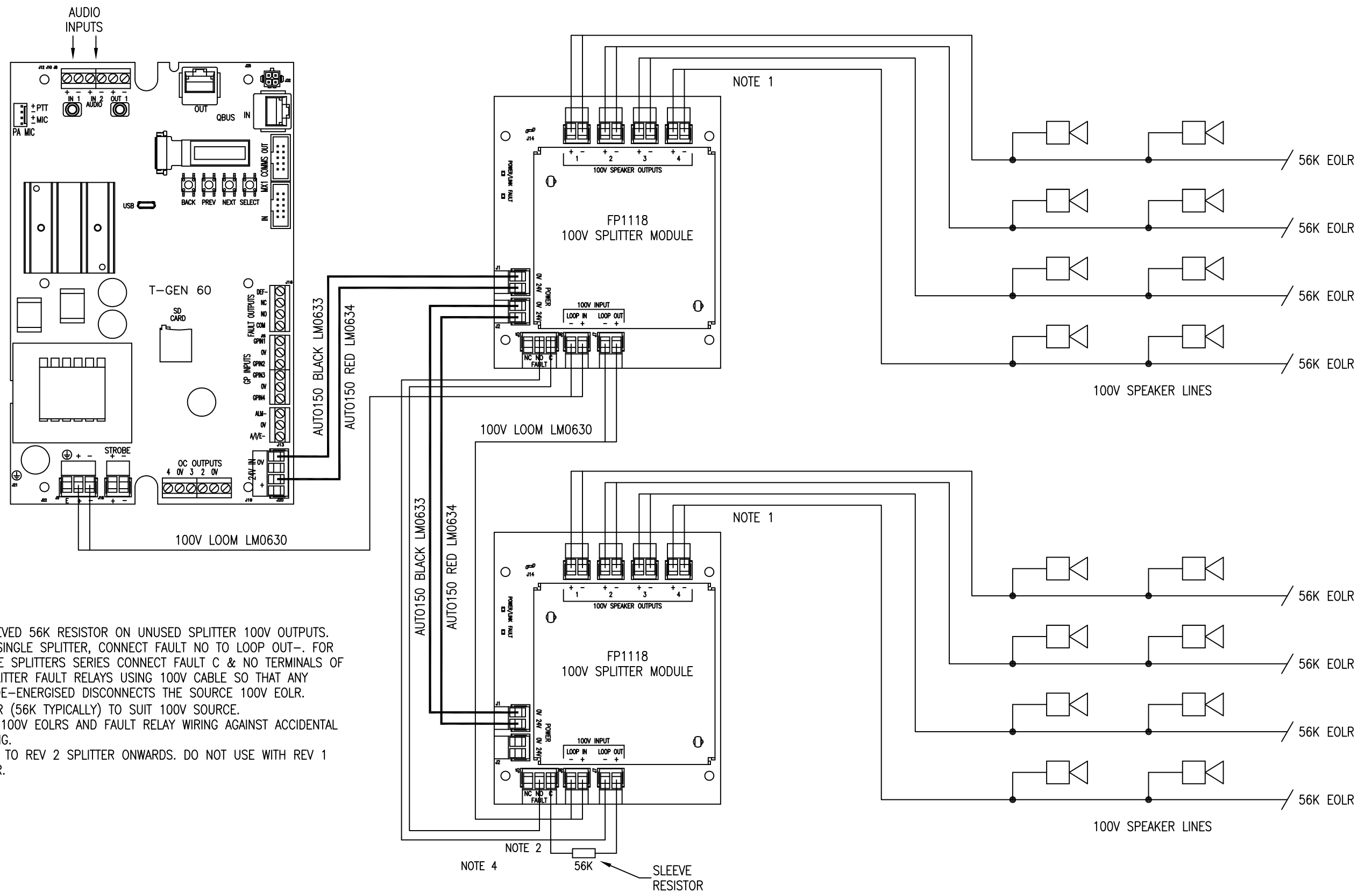

NOTES:

1. FIT SLEEVED 56K RESISTOR ON UNUSED SPLITTER 100V OUTPUTS.
2. FOR A SINGLE SPLITTER, CONNECT FAULT NO TO LOOP OUT-. FOR MULTIPLE SPLITTERS SERIES CONNECT FAULT C & NO TERMINALS OF ALL SPLITTER FAULT RELAYS USING 100V CABLE SO THAT ANY RELAY DE-ENERGISED DISCONNECTS THE SOURCE 100V EOLR.
3. FIT EOLR (56K TYPICALLY) TO SUIT 100V SOURCE.
4. SLEEVE 100V EOLRS AND FAULT RELAY WIRING AGAINST ACCIDENTAL TOUCHING.
5. APPLIES TO REV 2 SPLITTER ONWARDS. DO NOT USE WITH REV 1 SPLITTER.

CONFIDENTIAL: THIS DOCUMENT MUST NOT BE COPIED NOR THE CONTENTS PASSED ON TO ANY THIRD PARTY WITHOUT THE CONSENT OF THE COMPANY.

UNLESS OTHERWISE STATED: ALL DIMENSIONS IN MILLIMETRES. DO NOT SCALE. TOLERANCES ARE TO BE: 1 DECIMAL PLACE ±0.5, 2 DECIMAL PLACES ±0.3, 3 DECIMAL PLACES ±0.1

3rd ANGLE PROJECTION

ISS/REV	AMENDMENTS	ECO	DRN	CHKD	AUTH	APVD	DATE
A	ORIGINAL	5022	KJS	RC	RC	DC	4-9-17
B	100V FAULT WIRING CHANGED FOR REV 2 SPLITTER	5233	SS	RAC	MH	DC	17-7-19

© 2019 Johnson Controls. All rights reserved. All specifications and other information shown were current as of document revision date and are subject to change without notice.

JOHNSON CONTROLS
 17 MARY MULLER DRIVE
 P.O. BOX 19545
 CHRISTCHURCH, PH: +64 3 3895096
 NEW ZEALAND. FAX: +64 3 3895938

T-GEN2
100V SPLITTER MODULE
WIRING DIAGRAM

DRAWING No: **1982-71** SHEET **135** of **N**

A3	ISS/REV B	PART No:	
-----------	------------------	----------	--

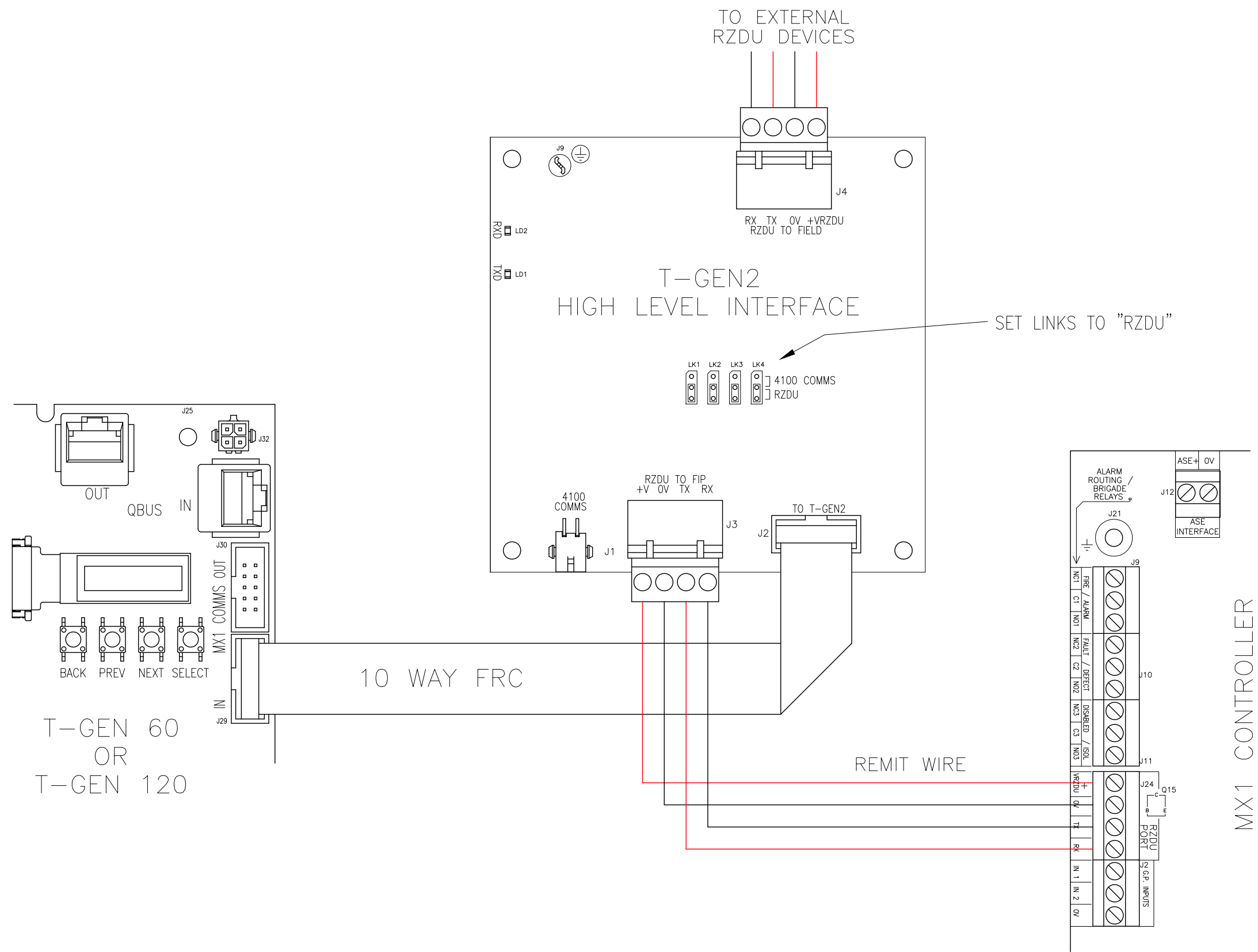

CONFIDENTIAL: THIS DOCUMENT MUST NOT BE COPIED NOR THE CONTENTS PASSED ON TO ANY THIRD PARTY WITHOUT THE CONSENT OF THE COMPANY.

UNLESS OTHERWISE STATED: ALL DIMENSIONS IN MILLIMETRES. DO NOT SCALE. TOLERANCES ARE TO BE: 1 DECIMAL PLACE ±0.5, 2 DECIMAL PLACES ±0.3, 3 DECIMAL PLACES ±0.1

3rd ANGLE PROJECTION

ISS/REV	AMENDMENTS	ECO	DRN	CHKD	AUTH	APVD	DATE
A	ORIGINAL	5140	KJS	RC	RC	DC	30-4-18

© 2018 Johnson Controls. All rights reserved. All specifications and other information shown were current as of document revision date and are subject to change without notice.

JOHNSON CONTROLS
 17 MARY MULLER DRIVE
 P.O. BOX 19545
 CHRISTCHURCH, PH: +64 3 3895096
 NEW ZEALAND. FAX: +64 3 3895938

MX1 T-GEN2 HLI MODULE WIRING DIAGRAM

DRAWING No: **1982-71** SHEET **136** of **N**

A3	ISS/REV A	PART No:	
-----------	------------------	----------	--

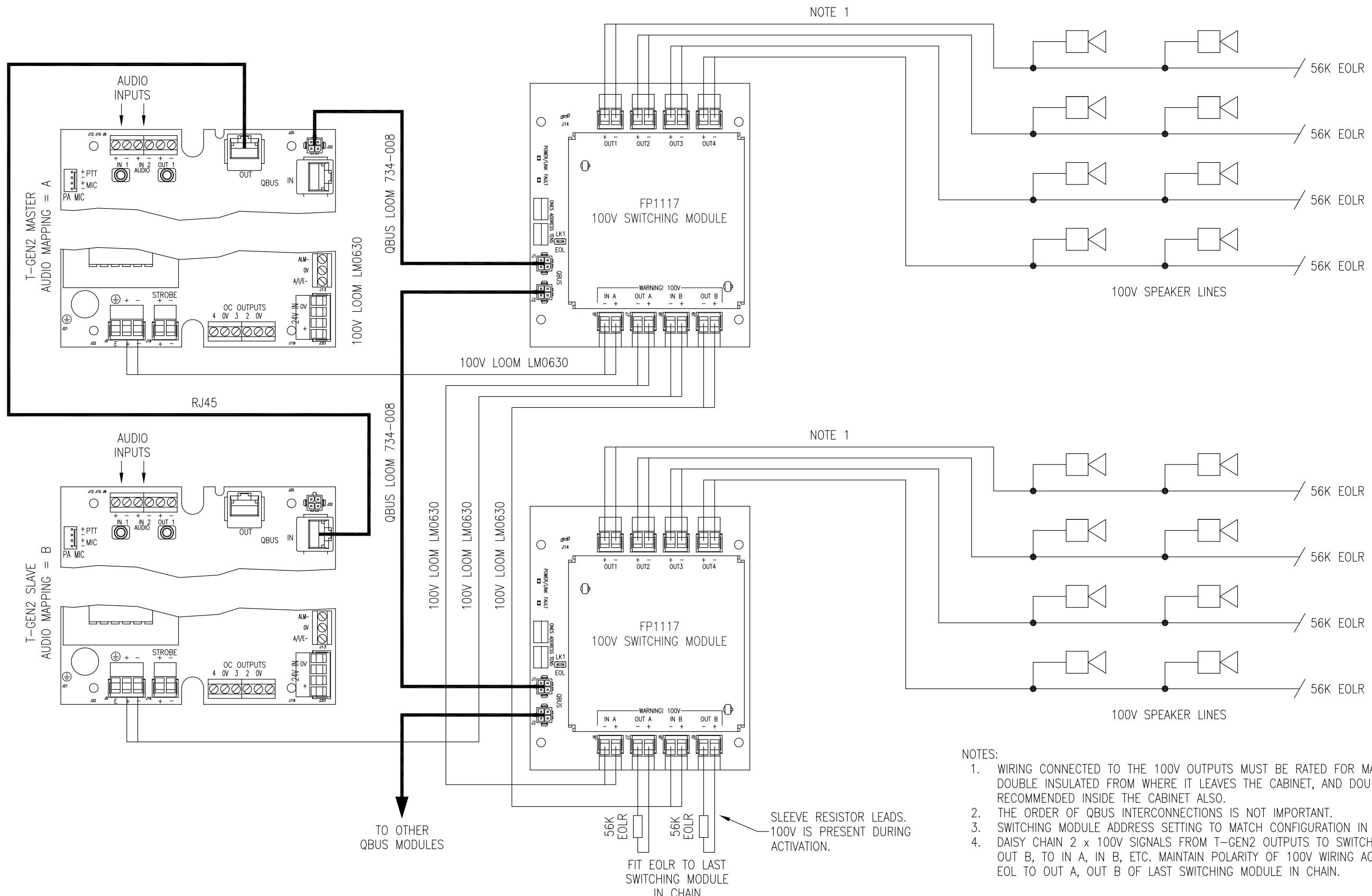

NOTE 1

NOTE 1

NOTES:

1. WIRING CONNECTED TO THE 100V OUTPUTS MUST BE RATED FOR MAINS VOLTAGE. IT MUST BE DOUBLE INSULATED FROM WHERE IT LEAVES THE CABINET, AND DOUBLE INSULATION IS RECOMMENDED INSIDE THE CABINET ALSO.
2. THE ORDER OF QBUS INTERCONNECTIONS IS NOT IMPORTANT.
3. SWITCHING MODULE ADDRESS SETTING TO MATCH CONFIGURATION IN SMARTCONFIG.
4. DAISY CHAIN 2 x 100V SIGNALS FROM T-GEN2 OUTPUTS TO SWITCHING MODULE IN A, IN B, OUT A OUT B, TO IN A, IN B, ETC. MAINTAIN POLARITY OF 100V WIRING ACROSS ALL MODULES. FIT 56K EOL TO OUT A, OUT B OF LAST SWITCHING MODULE IN CHAIN.

TO OTHER QBUS MODULES

56K EOLR
56K EOLR
SLEEVE RESISTOR LEADS. 100V IS PRESENT DURING ACTIVATION.
FIT EOLR TO LAST SWITCHING MODULE IN CHAIN

CONFIDENTIAL: THIS DOCUMENT MUST NOT BE COPIED NOR THE CONTENTS PASSED ON TO ANY THIRD PARTY WITHOUT THE CONSENT OF THE COMPANY.

UNLESS OTHERWISE STATED: ALL DIMENSIONS IN MILLIMETRES. DO NOT SCALE. TOLERANCES ARE TO BE: 1 DECIMAL PLACE ±0.5, 2 DECIMAL PLACES ±0.3, 3 DECIMAL PLACES ±0.1

3rd ANGLE PROJECTION

ISS/REV	AMENDMENTS	ECO	DRN	CHKD	AUTH	APVD	DATE
A	ORIGINAL	5142	KJS	PV	RC	DC	15-10-18

© 2017 Johnson Controls. All rights reserved. All specifications and other information shown were current as of document revision date and are subject to change without notice.

JOHNSON CONTROLS
17 MARY MULLER DRIVE
P.O. BOX 19545
CHRISTCHURCH, PH: +64 3 3895096
NEW ZEALAND. FAX: +64 3 3895938

**T-GEN2
DUAL 100V SWITCHING MODULE
WIRING DIAGRAM**

DRAWING No: **1982-71** SHEET **137** of **N**

A3	ISS/REV A	PART No:
-----------	------------------	----------

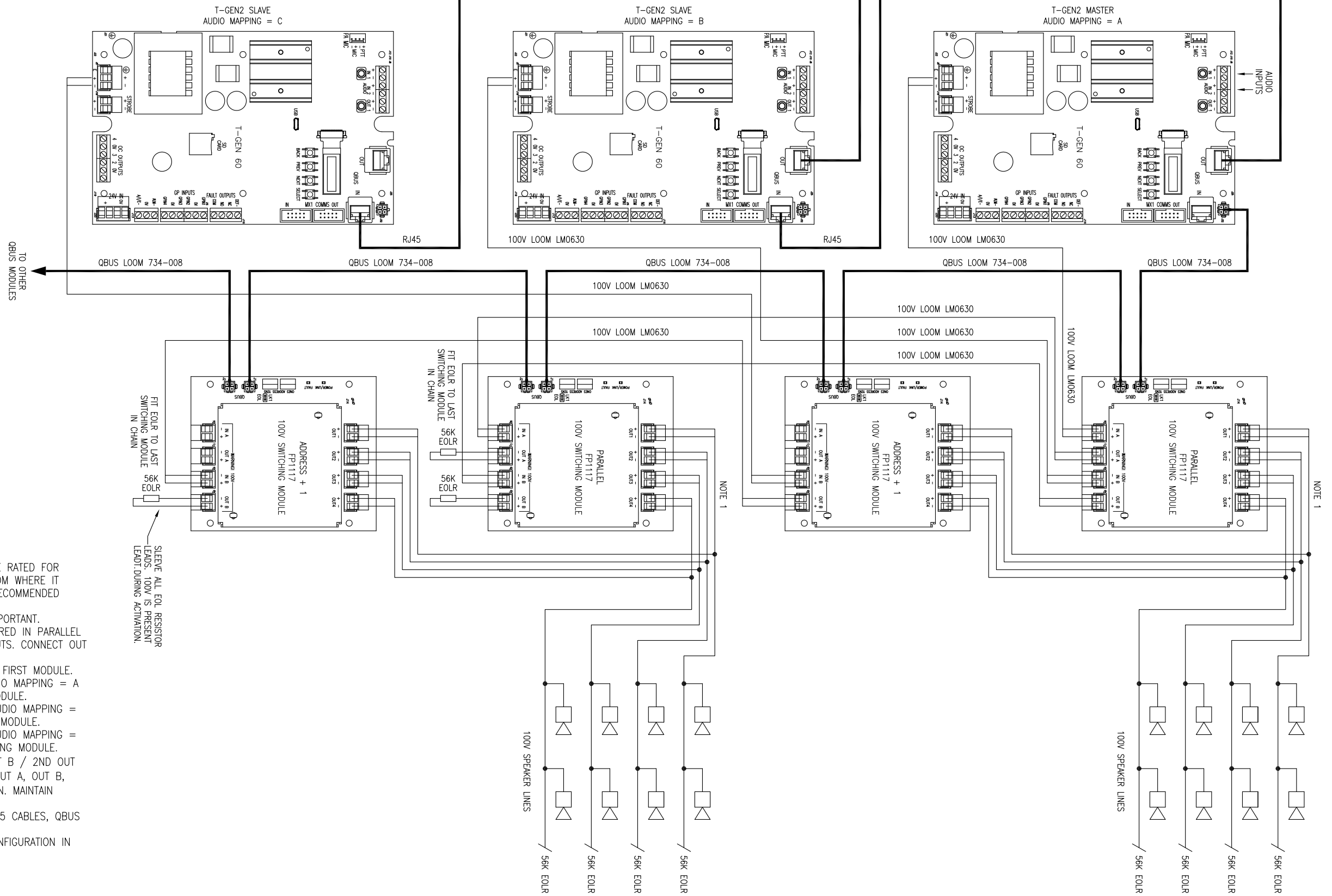

- NOTES:
1. WIRING CONNECTED TO THE 100V OUTPUTS MUST BE RATED FOR MAINS VOLTAGE. IT MUST BE DOUBLE INSULATED FROM WHERE IT LEAVES THE CABINET, AND DOUBLE INSULATION IS RECOMMENDED INSIDE THE CABINET ALSO.
 2. THE ORDER OF QBUS INTERCONNECTIONS IS NOT IMPORTANT.
 3. 100V OUTPUTS OF TWO SWITCHING MODULES ARE WIRED IN PARALLEL TO PROVIDE 4 OUTPUTS WITH 3 X 100V AUDIO INPUTS. CONNECT OUT 1+ TO OUT 1+, OUT 1- TO OUT 1-, ETC.
 4. 2ND MODULE IS CONFIGURED WITH ADDRESS +1 OF FIRST MODULE.
 5. THE 100V OUTPUT OF T-GEN2 CONFIGURED AS AUDIO MAPPING = A IS WIRED TO 100V IN A OF PARALLEL SWITCHING MODULE.
 6. THE 100V OUTPUT OF T-GEN2 CONFIGURED WITH AUDIO MAPPING = B IS WIRED TO 100V IN B OF PARALLEL SWITCHING MODULE.
 7. THE 100V OUTPUT OF T-GEN2 CONFIGURED WITH AUDIO MAPPING = C IS WIRED TO 100V IN B OF ADDRESS +1 SWITCHING MODULE.
 8. DAISY CHAIN 3 x 100V SIGNALS FROM OUT A / OUT B / 2ND OUT B TO IN A / IN B / 2ND IN B; ETC. FIT EOLR TO OUT A, OUT B, 2ND OUT B OF LAST SWITCHING MODULE(S) IN CHAIN. MAINTAIN POLARITY OF 100V WIRING ACROSS MODULES
 9. T-GEN2 MODULES CONNECTED TOGETHER USING RJ45 CABLES, QBUS OUT TO QBUS IN.
 10. SWITCHING MODULE ADDRESS SETTING TO MATCH CONFIGURATION IN SMARTCONFIG.

CONFIDENTIAL: THIS DOCUMENT MUST NOT BE COPIED NOR THE CONTENTS PASSED ON TO ANY THIRD PARTY WITHOUT THE CONSENT OF THE COMPANY.

UNLESS OTHERWISE STATED: ALL DIMENSIONS IN MILLIMETRES. DO NOT SCALE. TOLERANCES ARE TO BE: 1 DECIMAL PLACE ±0.5, 2 DECIMAL PLACES ±0.3, 3 DECIMAL PLACES ±0.1

3rd ANGLE PROJECTION

ISS/REV	AMENDMENTS	ECO	DRN	CHKD	AUTH	APVD	DATE
A	ORIGINAL	5142	KJS	PV	RC	DC	15-10-18

© 2017 Johnson Controls. All rights reserved. All specifications and other information shown were current as of document revision date and are subject to change without notice.

JOHNSON CONTROLS
 17 MARY MULLER DRIVE
 P.O. BOX 19545
 CHRISTCHURCH, PH: +64 3 3895096
 NEW ZEALAND. FAX: +64 3 3895938

T-GEN2
TRIPLE 100V SWITCHING MODULE
WIRING DIAGRAM

DRAWING No: **1982-71** SHEET **138** of **N**

A3 | ISS/REV **A** | PART No:

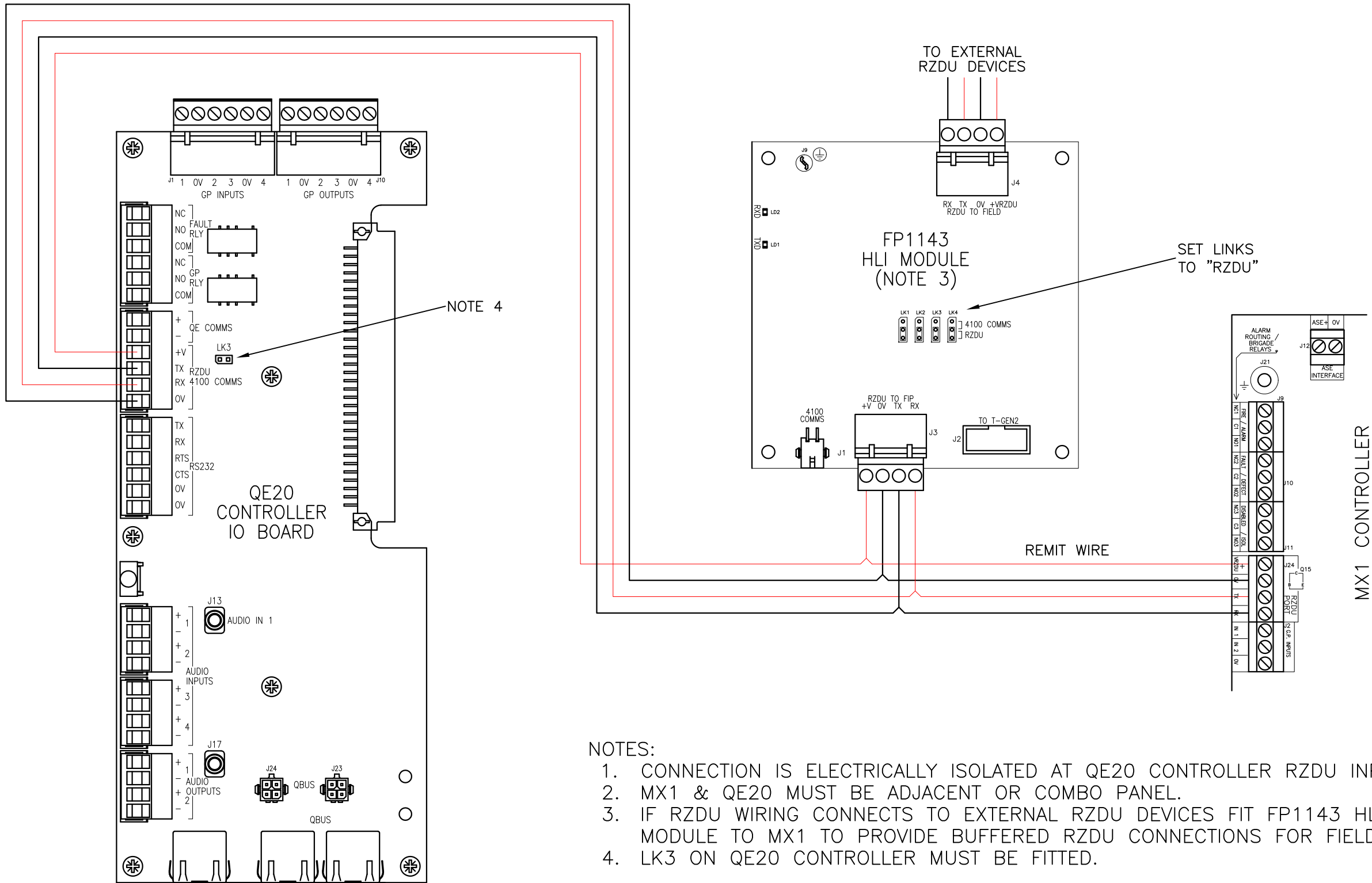

- NOTES:
1. CONNECTION IS ELECTRICALLY ISOLATED AT QE20 CONTROLLER RZDU INPUT.
 2. MX1 & QE20 MUST BE ADJACENT OR COMBO PANEL.
 3. IF RZDU WIRING CONNECTS TO EXTERNAL RZDU DEVICES FIT FP1143 HLI MODULE TO MX1 TO PROVIDE BUFFERED RZDU CONNECTIONS FOR FIELD WIRING.
 4. LK3 ON QE20 CONTROLLER MUST BE FITTED.

CONFIDENTIAL: THIS DOCUMENT MUST NOT BE COPIED NOR THE CONTENTS PASSED ON TO ANY THIRD PARTY WITHOUT THE CONSENT OF THE COMPANY.

UNLESS OTHERWISE STATED: ALL DIMENSIONS IN MILLIMETRES. DO NOT SCALE. TOLERANCES ARE TO BE: 1 DECIMAL PLACE ±0.5, 2 DECIMAL PLACES ±0.3, 3 DECIMAL PLACES ±0.1

3rd ANGLE PROJECTION

ISS/REV	AMENDMENTS	ECO	DRN	CHKD	AUTH	APVD	DATE
A	ORIGINAL	5378	KJS	RC	MH	DC	1-12-20

© 2023 Johnson Controls. All rights reserved. All specifications and other information shown were current as of document revision date and are subject to change without notice.

JOHNSON CONTROLS
 17 MARY MULLER DRIVE
 P.O. BOX 19545
 CHRISTCHURCH, PH: +64 3 3895096
 NEW ZEALAND. FAX: +64 3 3895938

MX1 QE20 RZDU INTERFACE WIRING DIAGRAM

DRAWING No: 1982-71 SHEET 139 of N

A3	ISS/REV A	PART No:
-----------	------------------	----------

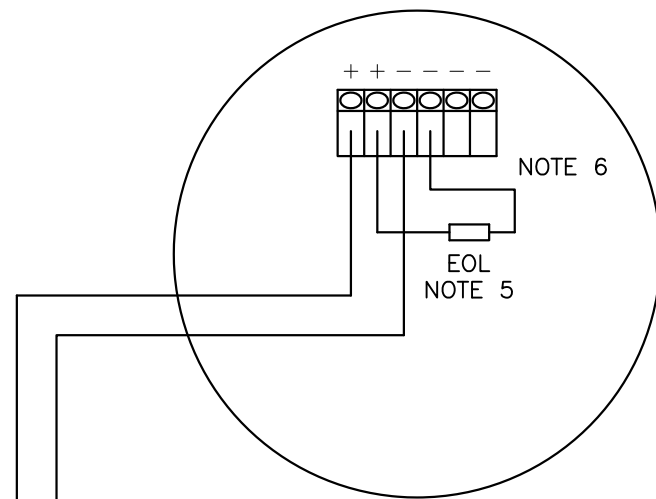

NOTES:

1. SET SOUNDER TONE = 25 (ISO 8201 970Hz)
SI : S5 = OFF : OFF : ON : ON : ON
VOL = ON (HIGH VOLUME)
2. SET BEACON FLASH RATE & POWER AS REQUIRED.
1: ON = 1Hz, OFF = 0.5Hz
2: ON = HIGH, OFF = LOW
3. THESE BEACONS ARE WHITE BODY.
4. ANC3 OUTPUT SUITABLE FOR 1 FLOOR OR AREA < 2000m² OF ALARM DEVICES.
5. EOL = 27K PER BRANCH (X3), FIT EXTRA 27K AT MX1.
6. DO NOT WIRE TO -VE(2) TERMINALS OTHERWISE INCORRECT TONES ARE PRODUCED.

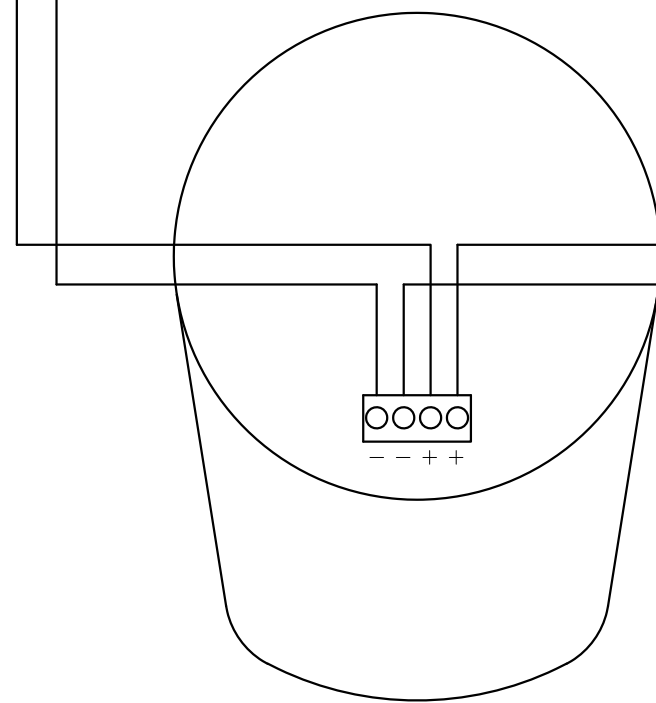

COMBINED SOUNDER & BEACON (VAD)
576.080.019 (WALL, RED FLASH, RED BODY)
576.080.024 (WALL, RED FLASH, WHITE BODY)
NOTE 1, 2

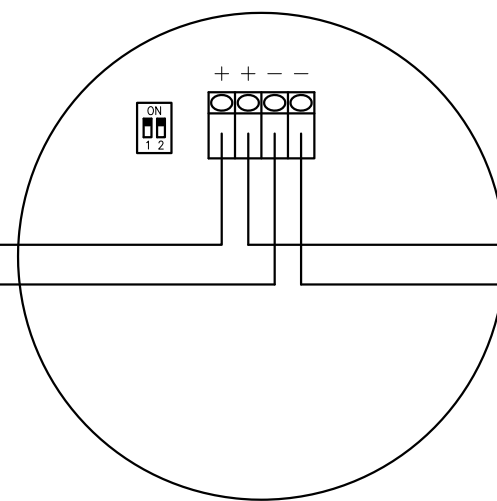

BEACON (VAD)
576.080.017 (CEILING, WHITE FLASH)
576.080.018 (WALL, WHITE FLASH)
576.080.022 (WALL, RED FLASH)
576.080.023 (CEILING, RED FLASH)
NOTE 2, 3

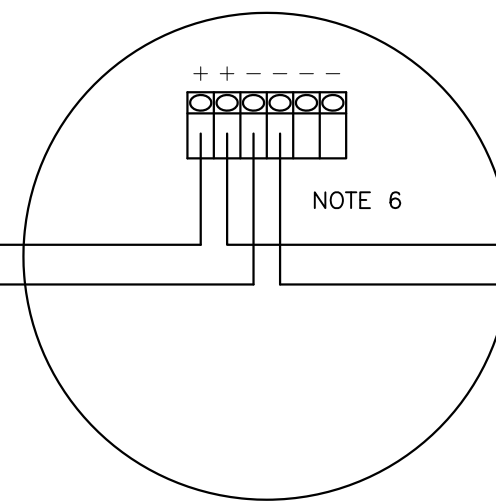

SOUNDERS (AAD)
576.080.020 (RED BODY)
576.080.025 (WHITE BODY)
NOTE 1

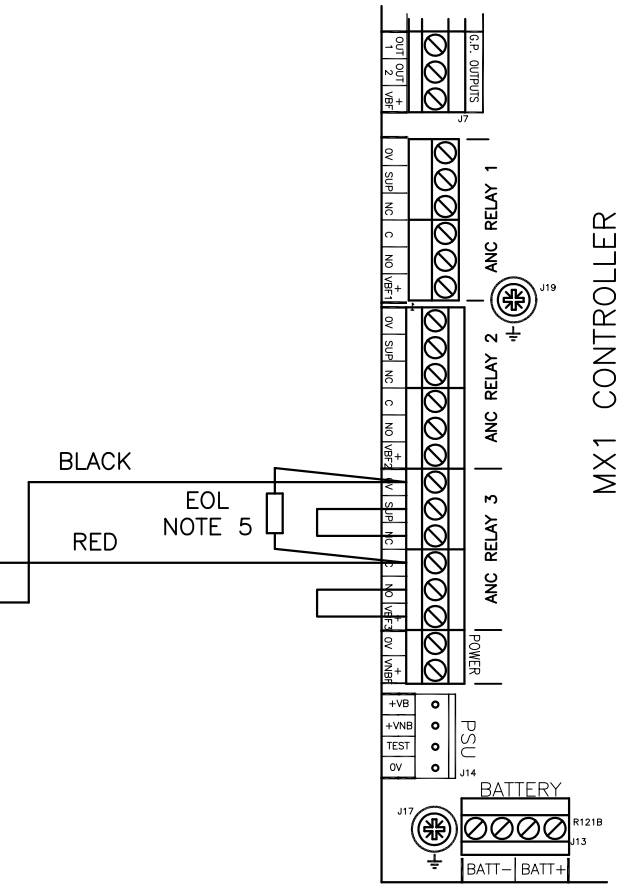

MX1 CONTROLLER

CONFIDENTIAL: THIS DOCUMENT MUST NOT BE COPIED NOR THE CONTENTS PASSED ON TO ANY THIRD PARTY WITHOUT THE CONSENT OF THE COMPANY.

UNLESS OTHERWISE STATED: ALL DIMENSIONS IN MILLIMETRES. DO NOT SCALE. TOLERANCES ARE TO BE: 1 DECIMAL PLACE ±0.5, 2 DECIMAL PLACES ±0.3, 3 DECIMAL PLACES ±0.1

3rd ANGLE PROJECTION

ISS/REV	AMENDMENTS	ECO	DRN	CHKD	AUTH	APVD	DATE
A	ORIGINAL	5276	KJS	RC	MH	DC	21-1-20

© 2020 Johnson Controls. All rights reserved. All specifications and other information shown were current as of document revision date and are subject to change without notice.

JOHNSON CONTROLS
17 MARY MULLER DRIVE
P.O. BOX 19545
CHRISTCHURCH, PH: +64 3 3895096
NEW ZEALAND. FAX: +64 3 3895938

MX1
ANC 3 TO CONV SOUNDERS / VADS
WIRING DIAGRAM

DRAWING No: 1982-71 SHEET 174 of N

A3	ISS/REV A	PART No:	
-----------	------------------	----------	--

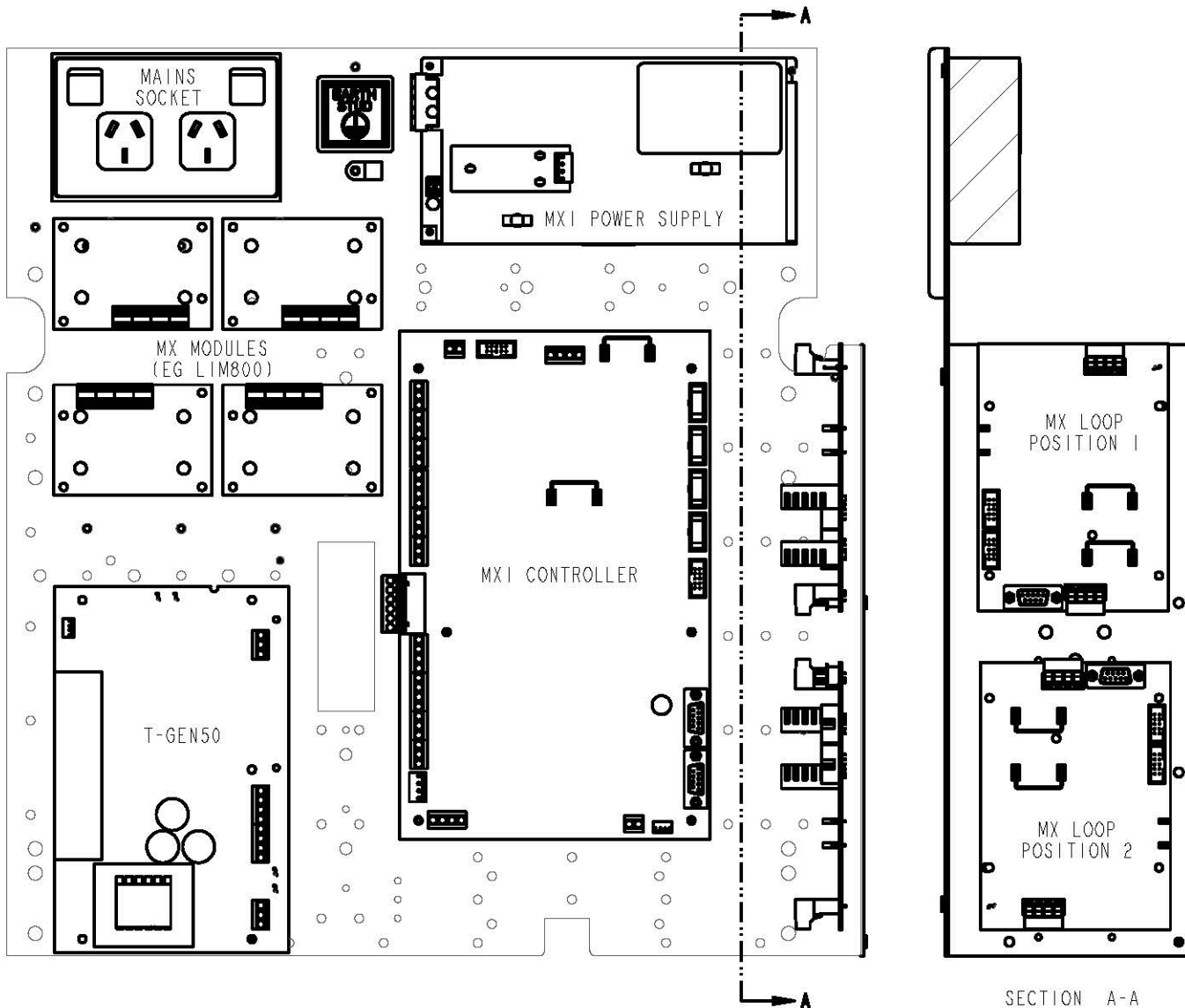

NOTES:

1. MOUNT T-GEN 50 USING 5 PLASTIC STAND-OFFS (HW0130) AND 1 OFF M3 X12 SCREW (SC0177). CENTRE LEFT PLASTIC STAND-OFF WILL NEED ITS RETAINING CLIP REMOVED. STAND-OFFS FACTORY FITTED FROM GEAR PLATE REAR.
2. MOUNT MX LOOP CARD USING 4 PLASTIC DOUBLE BARB STAND-OFFS (HW0052) SUPPLIED IN KIT. STAND-OFFS FITTED FROM GEAR PLATE FRONT.
3. MOUNT MX MODULES USING 4 PLASTIC DOUBLE BARB PCB STAND-OFFS (HW0052) FITTED FROM FRONT OF GEAR PLATE.

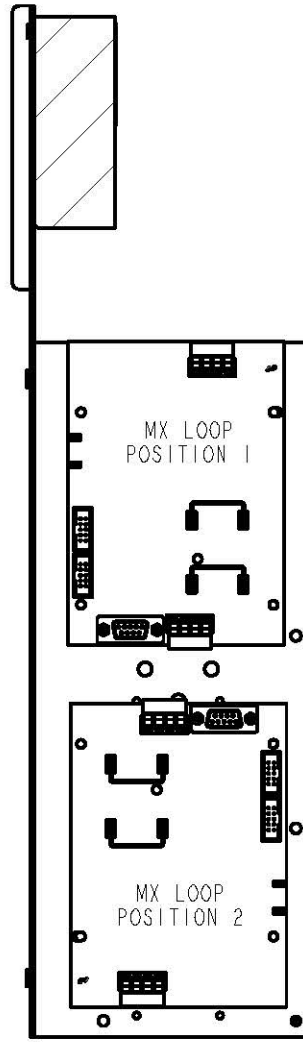

SECTION A-A

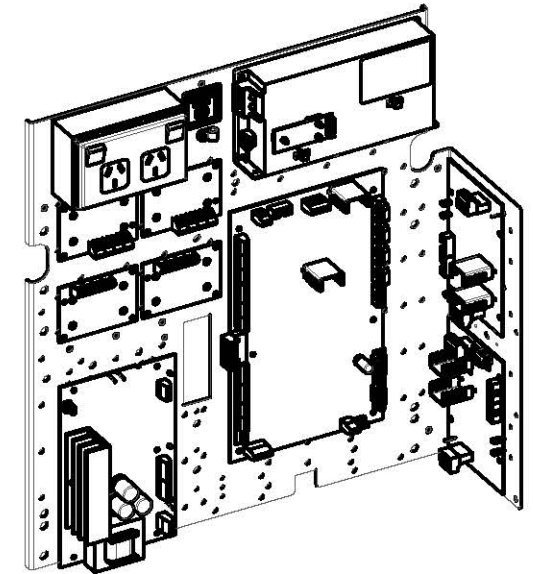

ISOMETRIC VIEW
SCALE 0.200

CONFIDENTIAL: THIS DOCUMENT MUST NOT BE COPIED NOR THE CONTENTS PASSED ON TO ANY THIRD PARTY WITHOUT THE CONSENT OF THE COMPANY.

UNLESS OTHERWISE STATED: ALL DIMENSIONS IN MILLIMETRES. DO NOT SCALE. TOLERANCES ARE TO BE: 1 DECIMAL PLACE ± 0.5 , 2 DECIMAL PLACES ± 0.3 , 3 DECIMAL PLACES ± 0.1

3rd ANGLE PROJECTION

ISS/REV	AMENDMENTS	ECO	DRN	CHKD	AUTH	APVD	DATE
B	UPDATED FOR NEW REV GEAR PLATE.	4167	KJS	LSC	RC	DP	20-08-10

tyco
Fire Protection Products

TYCO FIRE PROTECTION PRODUCTS
17 MARY MULLER DRIVE
P.O. BOX 19545
CHRISTCHURCH, PH: +64 3 3895096
NEW ZEALAND. FAX: +64 3 3895938

MX1		
T-GEN50, MX MODULES, MX LOOP		
GEARPLATE POSITIONS		
DRAWING No: 1982-71		SHEET 140 of N
A3	ISS/REV B	PART No:

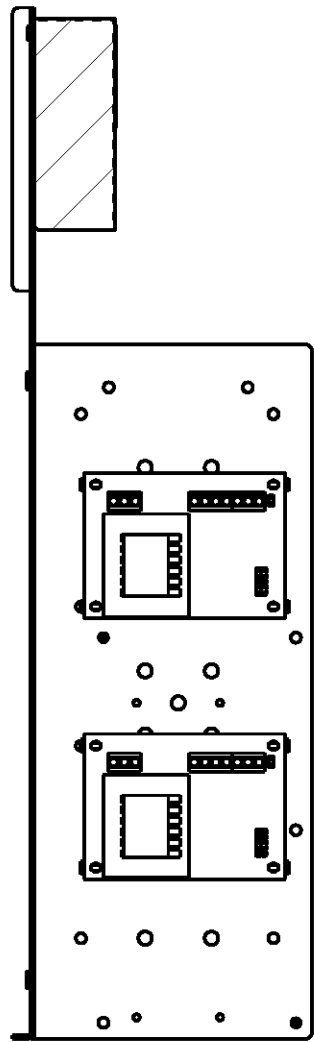
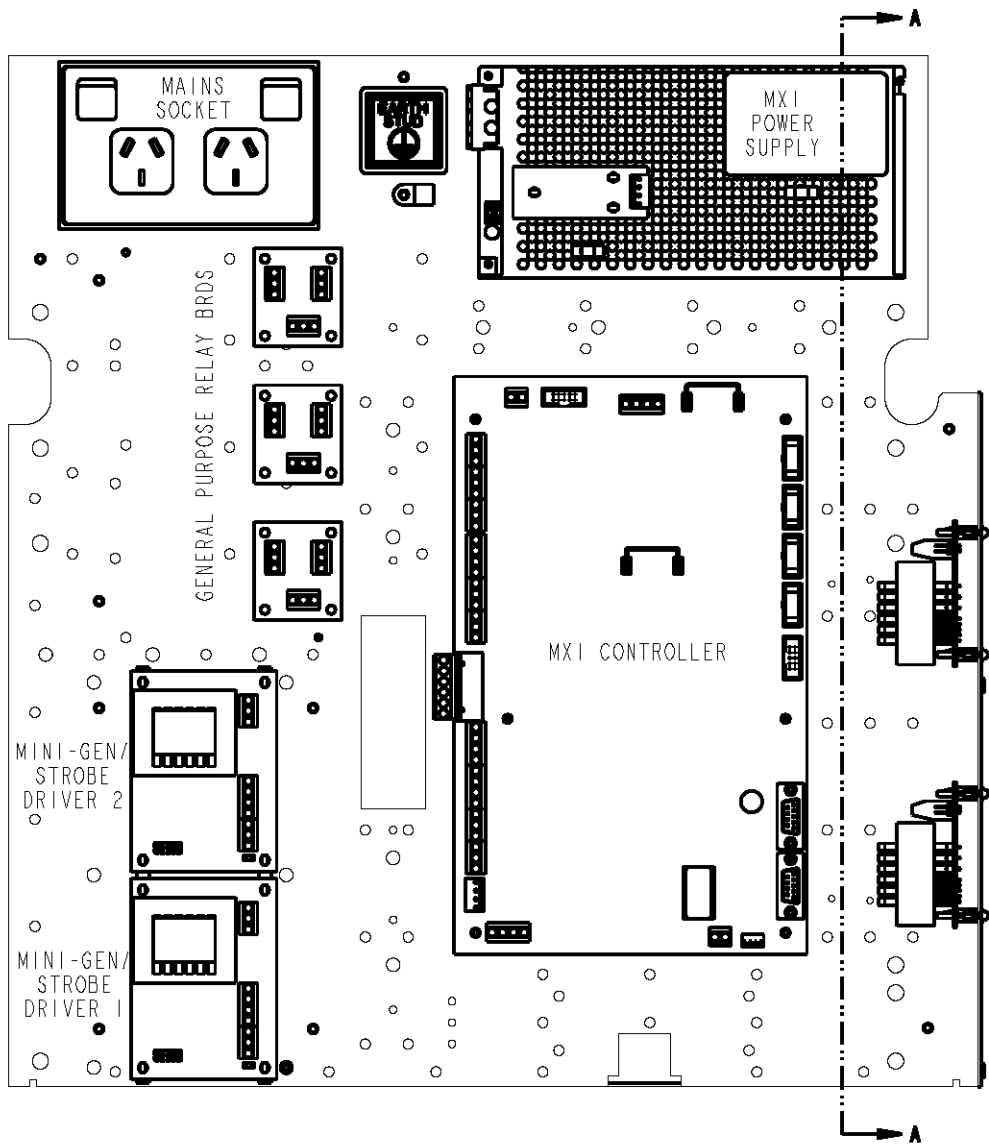

SECTION A-A

NOTES:

1. MOUNT MINI-GEN OR STROBE DRIVER USING 4 PLASTIC DOUBLE BARB PCB STAND-OFFS (HW0052) FITTED FROM FRONT OF GEAR PLATE.
2. MOUNT GENERAL PURPOSE RELAY BOARDS USING 4 PLASTIC DOUBLE BARB PCB STAND-OFFS (HW0052) PER BOARD, FITTED FROM FRONT OF GEAR PLATE.

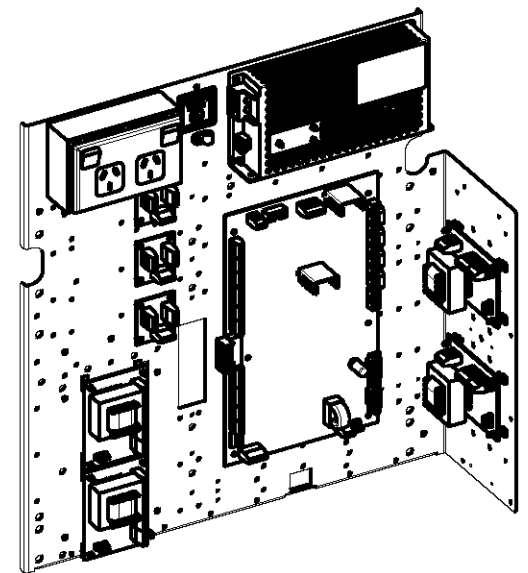

ISOMETRIC VIEW
SCALE 0.200

CONFIDENTIAL: THIS DOCUMENT MUST NOT BE COPIED NOR THE CONTENTS PASSED ON TO ANY THIRD PARTY WITHOUT THE CONSENT OF THE COMPANY.

UNLESS OTHERWISE STATED: ALL DIMENSIONS IN MILLIMETRES. DO NOT SCALE. TOLERANCES ARE TO BE: 1 DECIMAL PLACE ± 0.5 , 2 DECIMAL PLACES ± 0.3 , 3 DECIMAL PLACES ± 0.1

3rd ANGLE PROJECTION

ISS/REV	AMENDMENTS	ECO	DRN	CHKD	AUTH	APVD	DATE
B	UPDATED FOR NEW REV GEAR PLATE.	4167	KJS	LSC	RC	DP	20-08-10
C	GP RELAY BRDS WERE ON SHEET 149.	-	KJS	RC	RC	DP	11-4-13

tyco
Fire Protection Products
TYCO FIRE PROTECTION PRODUCTS
17 MARY MULLER DRIVE
P.O. BOX 19545
CHRISTCHURCH, PH: +64 3 3895096
NEW ZEALAND. FAX: +64 3 3895938

MX1
MINI-GEN / STROBE DR / GP RELAY
GEARPLATE POSITIONS

DRAWING No: **1982-71** SHEET **141** of **N**

A3	ISS/REV C	PART No:
-----------	------------------	----------

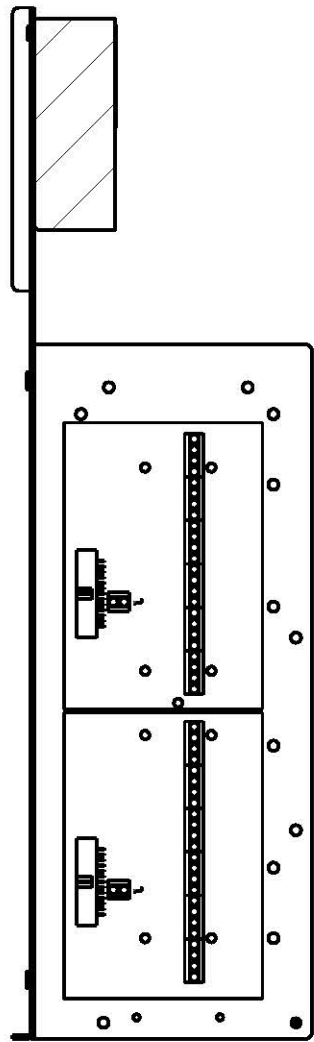
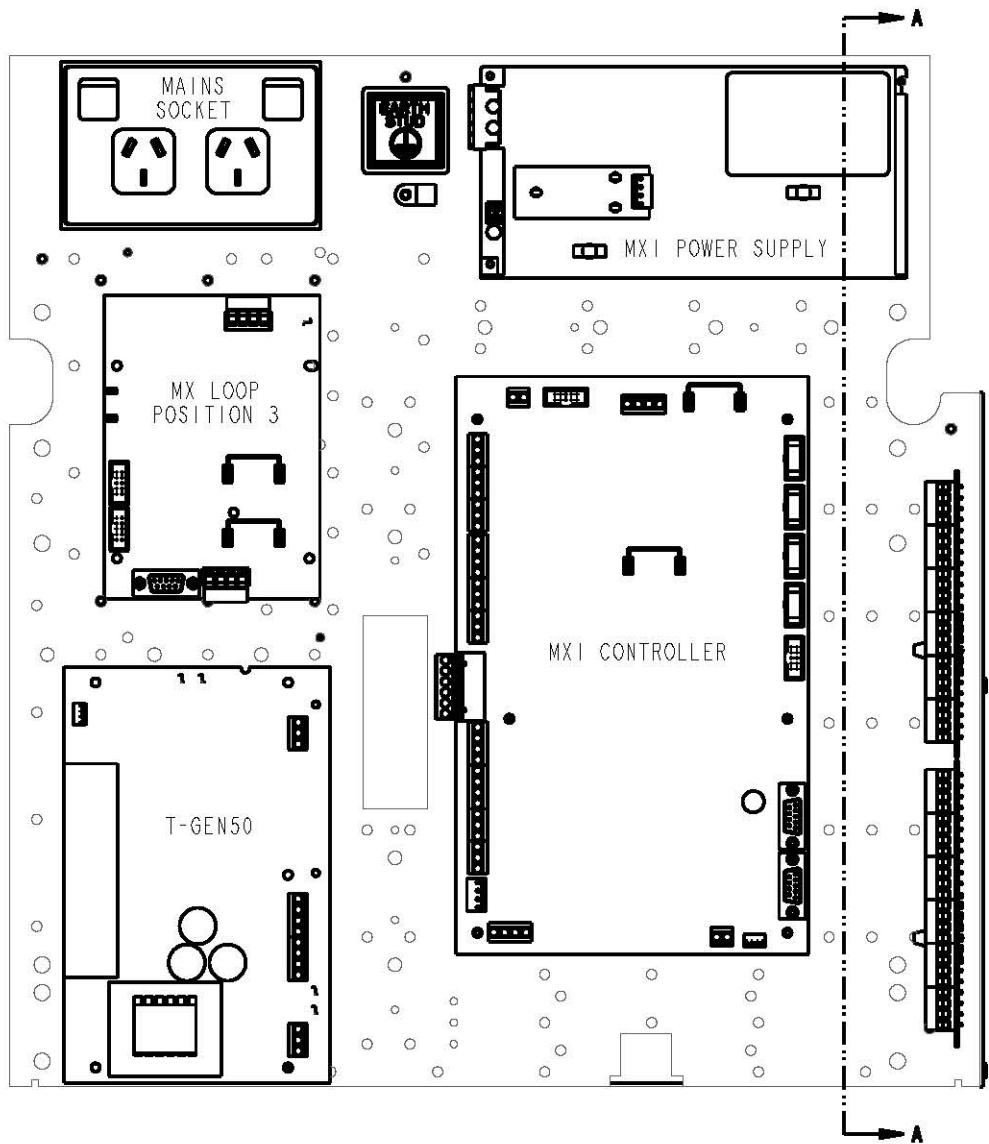

SECTION A-A

NOTES:

1. MOUNT 16 WAY INPUT AND 16 WAY OUTPUT BOARDS USING 4 PLASTIC PCB STAND-OFFS (HW0130) FITTED FROM REAR OF GEAR PLATE SIDE FOLD.
2. MOUNT MXI LOOP CARD USING 4 PLASTIC DOUBLE BARB PCB STAND-OFFS (HW0052) FITTED FROM FRONT OF GEAR PLATE.

16 WAY
INPUT BRD

16 WAY
OUTPUT BRD

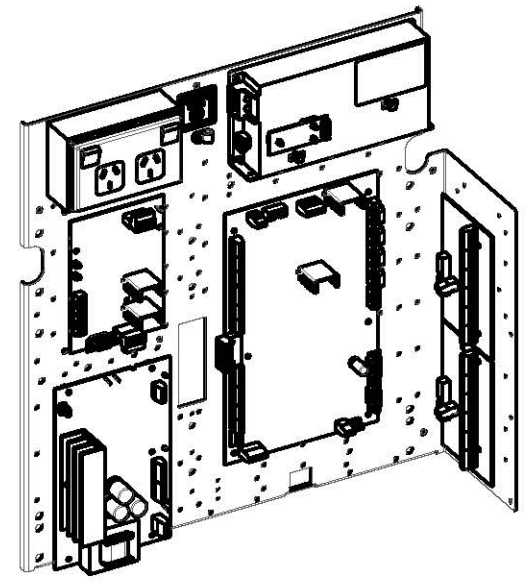

ISOMETRIC VIEW
SCALE 0.200

CONFIDENTIAL: THIS DOCUMENT MUST NOT BE COPIED NOR THE CONTENTS PASSED ON TO ANY THIRD PARTY WITHOUT THE CONSENT OF THE COMPANY.

UNLESS OTHERWISE STATED: ALL DIMENSIONS IN MILLIMETRES. DO NOT SCALE. TOLERANCES ARE TO BE: 1 DECIMAL PLACE ± 0.5 , 2 DECIMAL PLACES ± 0.3 , 3 DECIMAL PLACES ± 0.1

3rd ANGLE PROJECTION

ISS/REV	AMENDMENTS	ECO	DRN	CHKD	AUTH	APVD	DATE
B	UPDATED FOR NEW REV GEAR PLATE.	4167	KJS	LSC	RC	DP	20-08-10

tyco
Fire Protection Products
TYCO FIRE PROTECTION PRODUCTS
17 MARY MULLER DRIVE
P.O. BOX 19545
CHRISTCHURCH, PH: +64 3 3895096
NEW ZEALAND. FAX: +64 3 3895938

MX1
16 INPUT, 16 OUTPUT, MX LOOP CARD
GEARPLATE POSITIONS

DRAWING No: **1982-71** SHEET **142** of **N**

A3	ISS/REV B	PART No:
-----------	------------------	----------

MXI POWER SUPPLY

6 POSITIONS FOR MOUNTING MX LOOP CARD ON BRACKETS (FP0950),
4 X MX MODULE BRACKETS (FP1062/3) AND MX MODULE BRACKETS (FP1027).

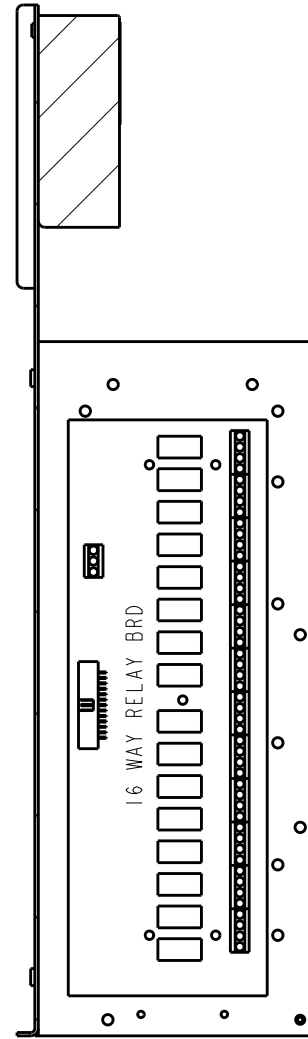
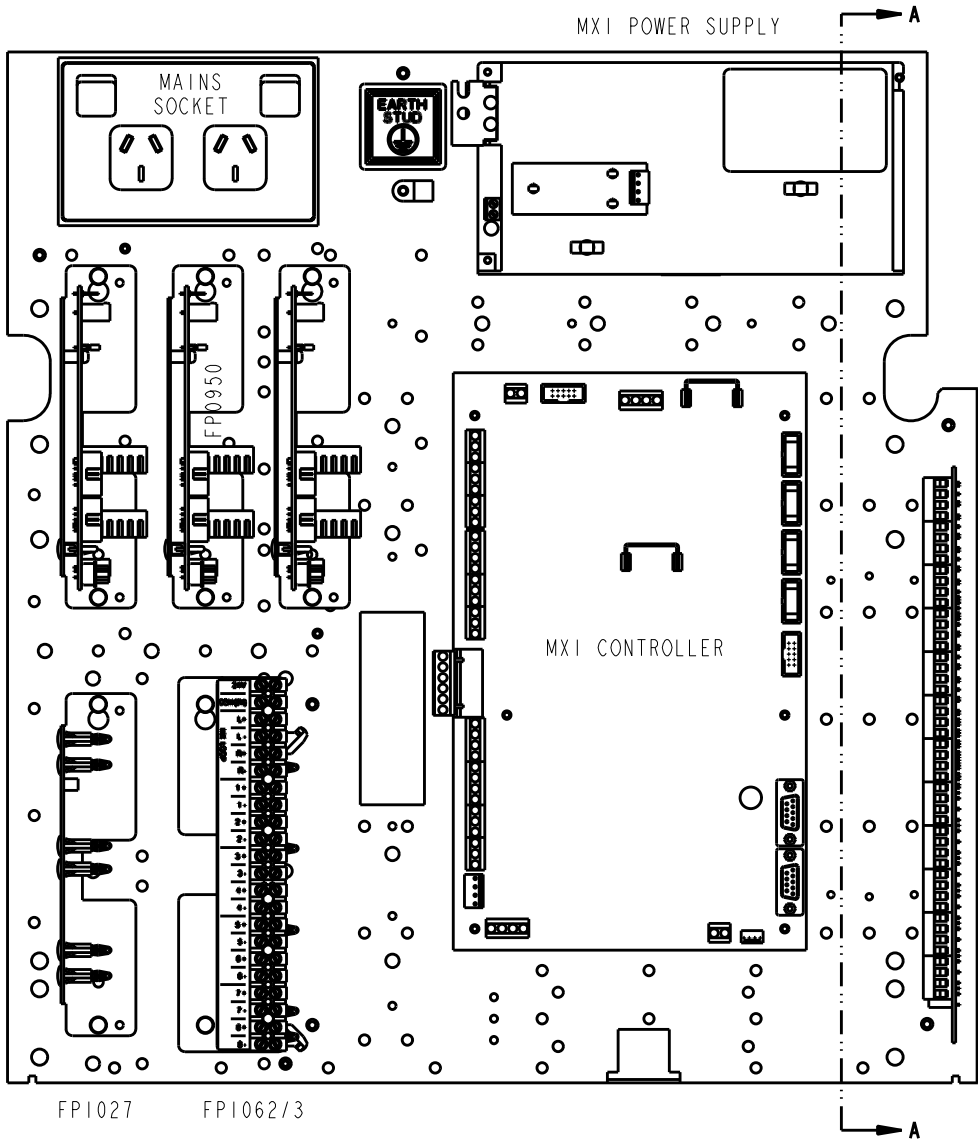

SECTION A-A

NOTES:

1. MOUNT 16-WAY RELAY BOARD ON GEAR PLATE USING 5 PLASTIC STAND-OFFS (HW0130) FITTED FROM REAR OF GEAR PLATE SIDE FOLD.
2. MOUNT EACH BRACKET MOUNTED MX LOOP CARD WITH 2 OFF M4 X 10 SCREWS (SC0176). SCREWS FITTED FROM GEAR PLATE FRONT.
3. MOUNT EACH MX MODULE MOUNTING BRACKET (FP1027, FP1062, FP1063) WITH 2 OFF M4 X 10 SCREWS (SC0176). SCREWS FITTED FROM GEAR PLATE FRONT.
4. MOUNT MX MODULES ON FP1027 BRACKET USING 4 PLASTIC PCB STAND-OFFS (HW0131) PROVIDED WITH BRACKET.
5. MOUNT MX MODULES ON FP1062 BRACKET USING 4 PLASTIC PCB STAND-OFFS (HW0209) PROVIDED WITH BRACKET.

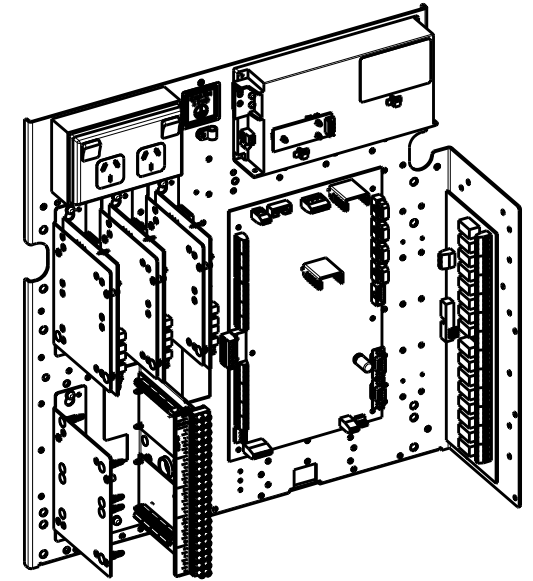

ISOMETRIC VIEW
SCALE 0.200

CONFIDENTIAL: THIS DOCUMENT MUST NOT BE COPIED NOR THE CONTENTS PASSED ON TO ANY THIRD PARTY WITHOUT THE CONSENT OF THE COMPANY.

UNLESS OTHERWISE STATED: ALL DIMENSIONS IN MILLIMETRES. DO NOT SCALE. TOLERANCES ARE TO BE: 1 DECIMAL PLACE ± 0.5 , 2 DECIMAL PLACES ± 0.3 , 3 DECIMAL PLACES ± 0.1

3rd ANGLE PROJECTION

ISS/REV	AMENDMENTS	ECO	DRN	CHKD	AUTH	APVD	DATE
B	UPDATED FOR NEW REV GEAR PLATE.	4167	KJS	LSC	RC	DP	20-08-10
C	NOTES UPDATED.	ECS1604	KJS	RC	RC	DP	21-11-11
D	FP1063 AND FP1027 MTG ADDED.	-	KJS	RC	RC	DP	22-1-15

© 2017 Johnson Controls. All rights reserved.
All specifications and other information shown were current as of document revision date and are subject to change without notice.

JOHNSON CONTROLS
17 MARY MULLER DRIVE
P.O. BOX 19545
CHRISTCHURCH, PH: +64 3 3895096
NEW ZEALAND. FAX: +64 3 3895938

MX1
16 WAY RELAY BRD, MX LOOP BRKTS
GEARPLATE POSITIONS

DRAWING No: 1982-71 SHEET 143 of N

A3	ISS/REV D	PART No:
----	-----------	----------

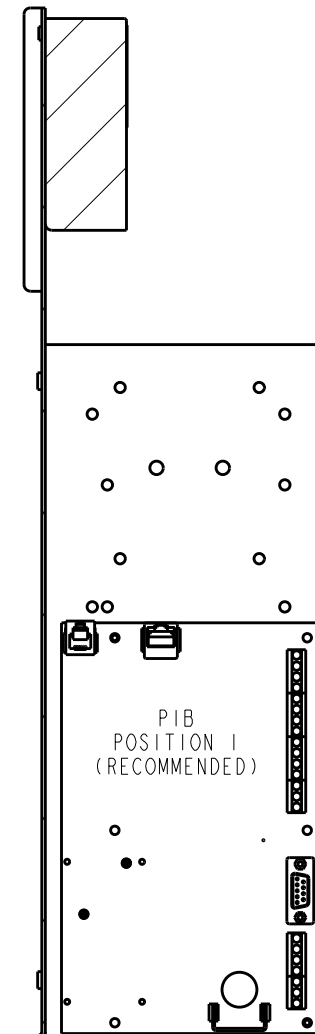
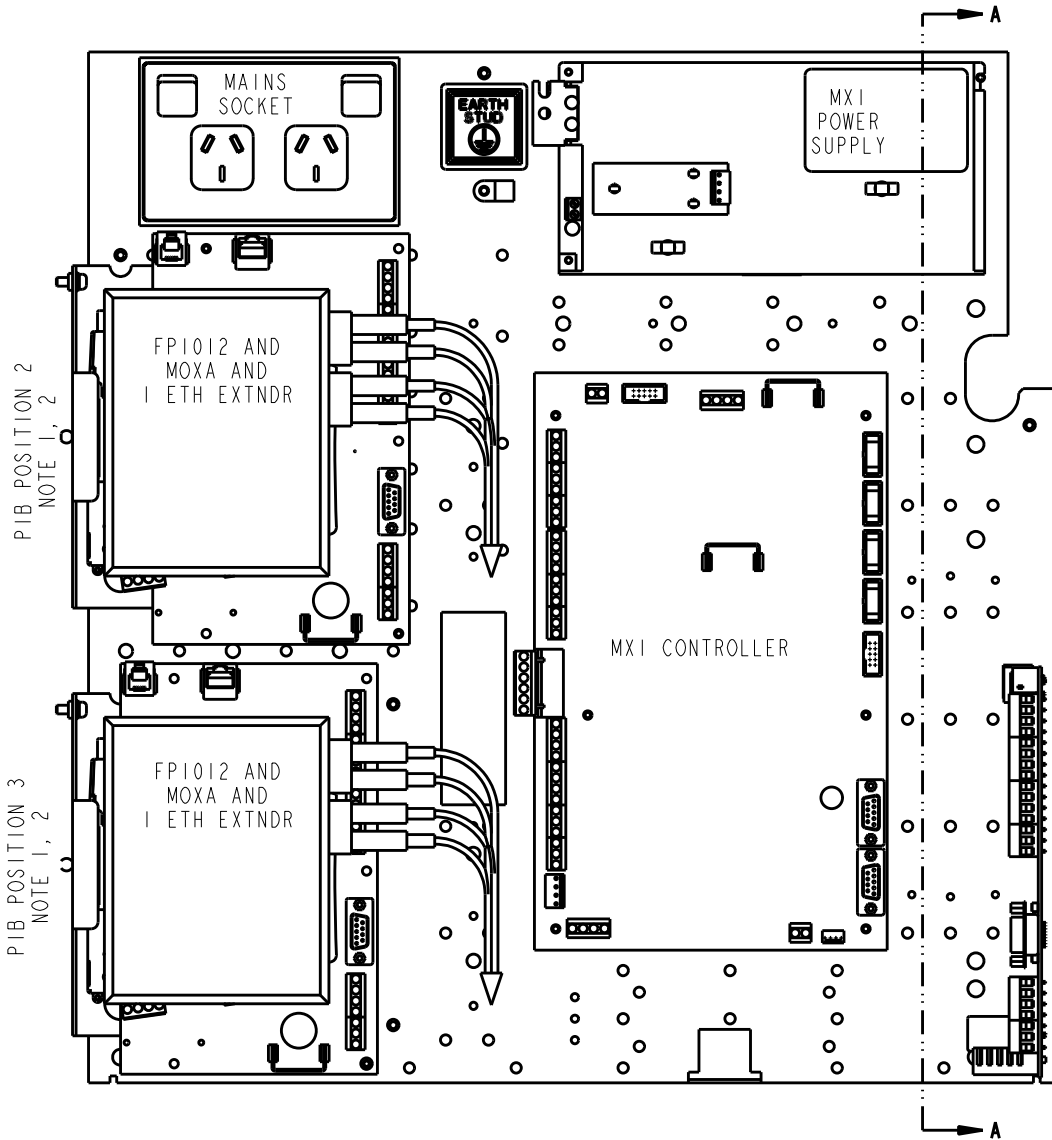

SECTION A-A

NOTES:

1. MOUNT PIB IN POSITION 1 OR 2 USING 2 OFF M3 M/F BARREL NUTS (FA2552) AND 2 OFF M3 X 6 SCREWS (SC0172) FITTED TO J17 AND J19. 4 PLASTIC DOUBLE BARB PCB STAND-OFFS (HW0052) ARE FITTED TO THE 4 REMAINING HOLES. BARREL NUTS AND PLASTIC DOUBLE BARB PCB STAND-OFFS ARE FITTED FROM GEAR PLATE FRONT.
2. MOUNT PIB IN POSITION 3 (NON-PREFERED) USING 5 OFF PLASTIC PCB STAND-OFFS PRE-FITTED TO THE GEAR PLATE AND 1 OFF M3 SCREW FITTED TO J17 ON THE BOTTOM RH METAL STAND-OFF.
3. MOUNTING THE PIB IN THE SAME POSITION AS THE FPI012 BRACKET IS A COMPROMISE. ONLY THE MOXA SWITCH OR 1 ETHERNET EXTENDER MAY BE ON THE FPI012 BRACKET, AND THE PIB LEDS ARE NOT VISIBLE.
4. THE MOXA SWITCH AND ETHERNET EXTENDER CLIP ONTO THE DIN RAIL ON THE FPI012 BRACKET. LEAVE A 10mm GAP EACH SIDE OF ETH EXTENDER FOR COOLING. CONNECT THE MOXA EARTH SCREW TO THE GEAR PLATE.
4. REFER TO INSTALLATION INSTRUCTIONS FOR FULL MOUNTING AND EARTHING DETAILS.

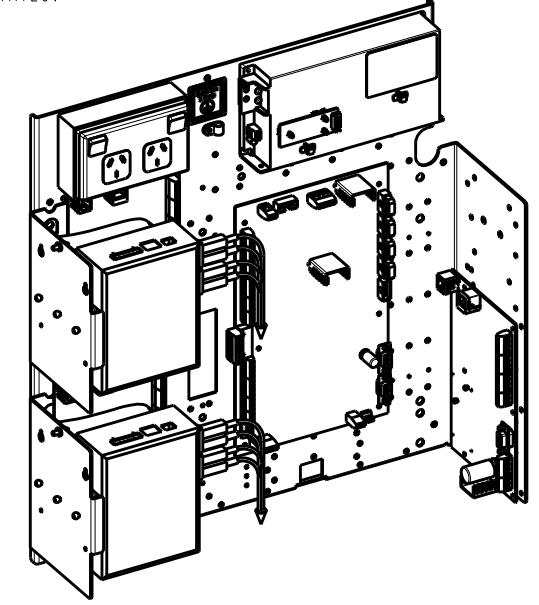

ISOMETRIC VIEW
SCALE 0.200

CONFIDENTIAL: THIS DOCUMENT MUST NOT BE COPIED NOR THE CONTENTS PASSED ON TO ANY THIRD PARTY WITHOUT THE CONSENT OF THE COMPANY.

UNLESS OTHERWISE STATED: ALL DIMENSIONS IN MILLIMETRES. DO NOT SCALE. TOLERANCES ARE TO BE: 1 DECIMAL PLACE ±0.5, 2 DECIMAL PLACES ±0.3, 3 DECIMAL PLACES ±0.1

3rd ANGLE PROJECTION

ISS/REV	AMENDMENTS	ECO	DRN	CHKD	AUTH	APVD	DATE
B	UPDATED FOR NEW REV GEAR PLATE.	4167	KJS	LSC	RC	DP	20-08-10
C	NOTES UPDATED, IP NETWORK EQUIP ADDED.	-	KJS	HW	RC	DP	12-4-13

© 2017 Johnson Controls. All rights reserved.
All specifications and other information shown were current as of document revision date and are subject to change without notice.

JOHNSON CONTROLS
17 MARY MULLER DRIVE
P.O. BOX 19545
CHRISTCHURCH, PH: +64 3 3895096
NEW ZEALAND. FAX: +64 3 3895938

MX1
PIB / IP NETWORK EQUIP
GEARPLATE POSITIONS

DRAWING No: 1982-71 SHEET 144 of N

A3	ISS/REV C	PART No:
-----------	------------------	----------

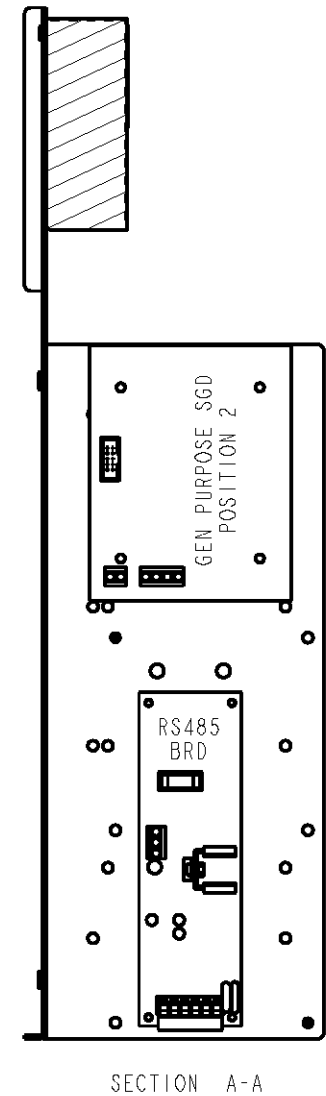
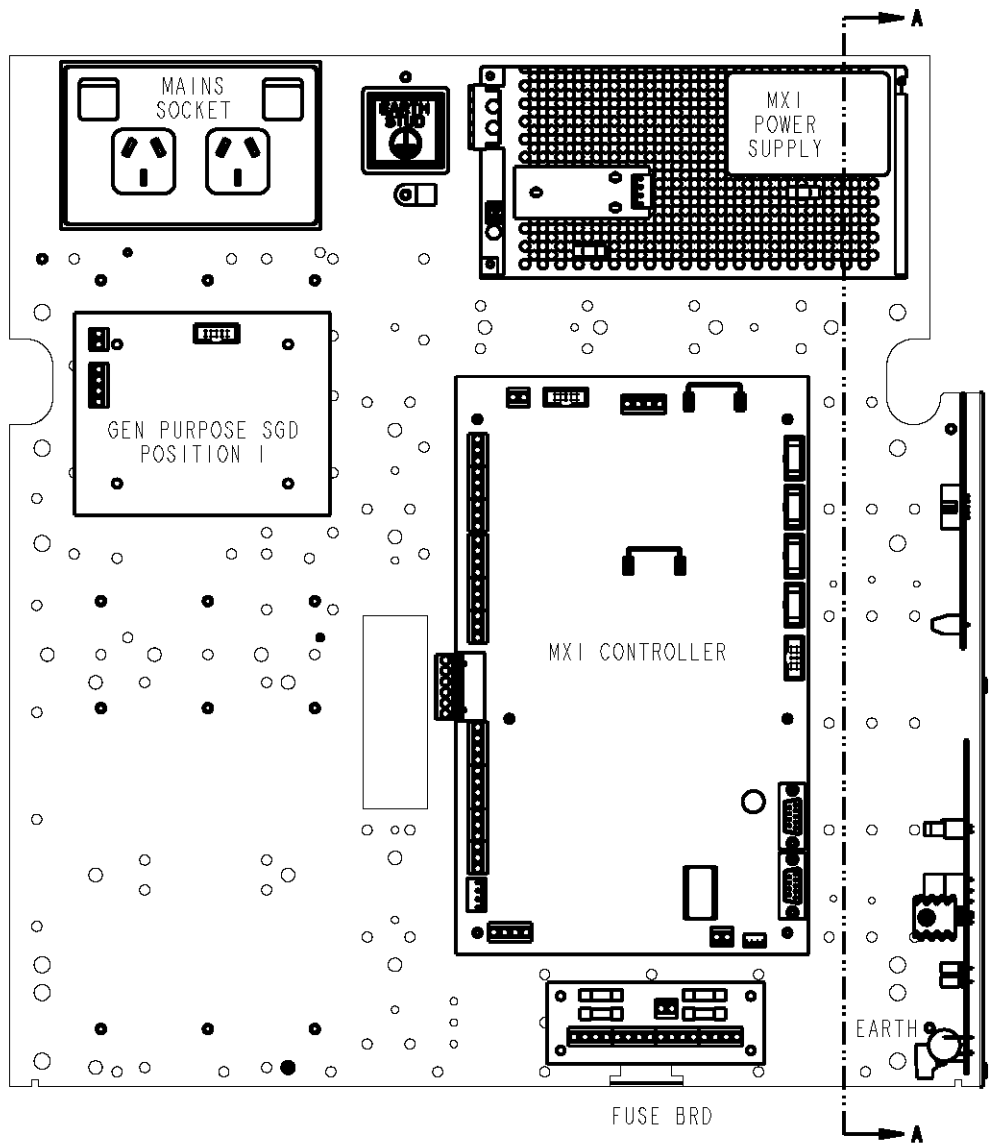

NOTES:

1. MOUNT RS485 BOARD USING 4 PLASTIC DOUBLE BARB PCB STAND-OFFS (HW0303) FITTED FROM GEAR PLATE FRONT. EARTH TO M4 SCREW IN BOTTOM RH CORNER.
2. MOUNT A GENERAL PURPOSE SGD (PA0862) USING 4 PLASTIC DOUBLE BARB PCB STAND-OFFS (HW0053) FITTED FROM GEAR PLATE FRONT.
3. MOUNT FUSE BOARD USING 4 PLASTIC DOUBLE BARB PCB STAND-OFFS (HW0052) FITTED FROM FRONT OF GEAR PLATE.

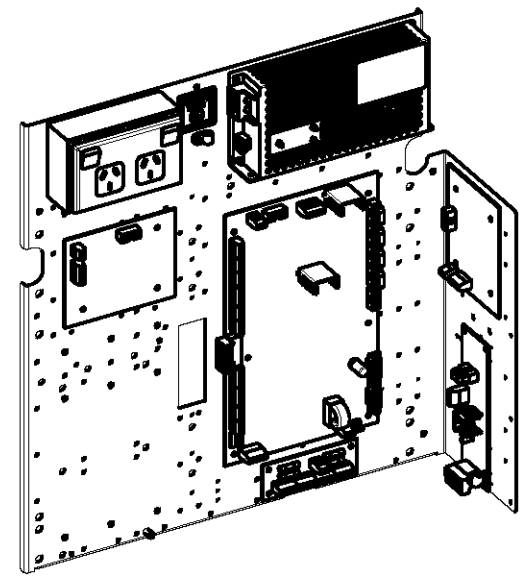

ISOMETRIC VIEW
SCALE 0.200

CONFIDENTIAL: THIS DOCUMENT MUST NOT BE COPIED NOR THE CONTENTS PASSED ON TO ANY THIRD PARTY WITHOUT THE CONSENT OF THE COMPANY.

UNLESS OTHERWISE STATED: ALL DIMENSIONS IN MILLIMETRES. DO NOT SCALE. TOLERANCES ARE TO BE: 1 DECIMAL PLACE ± 0.5 , 2 DECIMAL PLACES ± 0.3 , 3 DECIMAL PLACES ± 0.1

3rd ANGLE PROJECTION

ISS/REV	AMENDMENTS	ECO	DRN	CHKD	AUTH	APVD	DATE
A	ORIGINAL	4167	KJS	LSC	RC	DP	20-08-10
B	SGD IN POSITION 1 ROTATED 180°	ECS1604	KJS	RC	RC	DP	22-11-11
C	FUSE BRD ADDED.	-	KJS	RC	RC	DP	12-4-13

tyco
Fire Protection Products
TYCO FIRE PROTECTION PRODUCTS
17 MARY MULLER DRIVE
P.O. BOX 19545
CHRISTCHURCH, PH: +64 3 3895096
NEW ZEALAND. FAX: +64 3 3895938

MX1
RS485 BRD, SGD, FUSE BRD
GEARPLATE POSITIONS

DRAWING No: **1982-71** SHEET **148** of **N**

A3	ISS/REV C	PART No:
-----------	------------------	----------

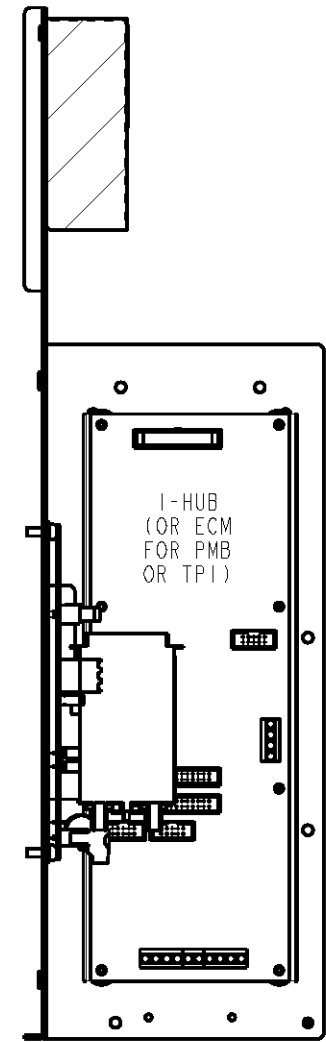
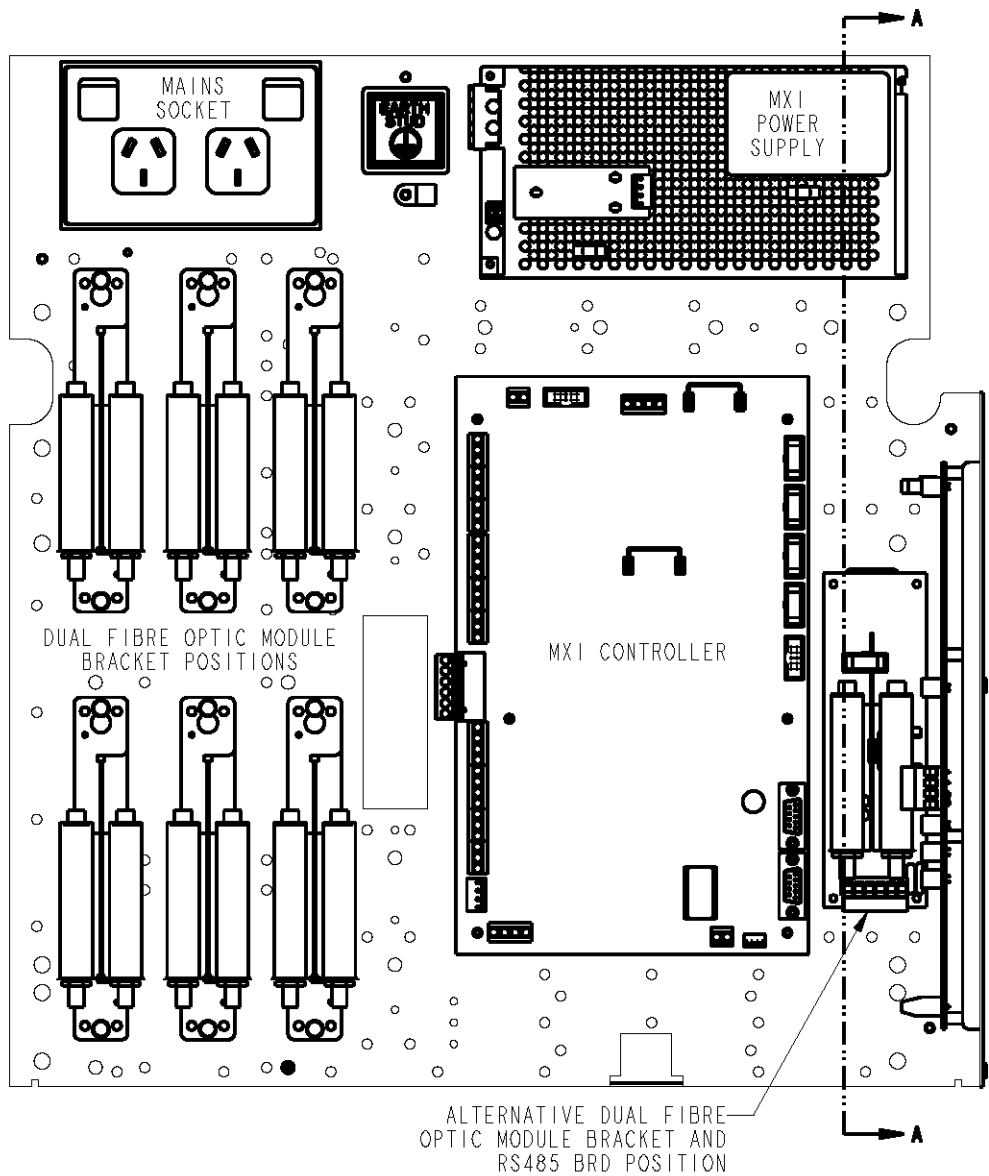

SECTION A-A

NOTES:

1. MOUNT THE I-HUB ON THE MOUNTING PLATE (FA2083) WITH 8 OFF M3 X 6 SCREWS (SC0172). MOUNT THE ECM MOUNTING PLATE ON THE GEAR PLATE SIDE FOLD USING 4 OFF M4 X 10 SCREWS (SC0176). M4 SCREWS FITTED FROM REAR OF GEAR PLATE SIDE FOLD.
2. MOUNT RS485 BOARD USING 4 PLASTIC DOUBLE BARB PCB STAND-OFFS (HW0303) FITTED FROM GEAR PLATE FRONT. EARTH TO M4 SCREW IN BOTTOM RH CORNER.
3. MOUNT THE DUAL OSD139 FIBRE OPTIC MODEM MOUNTING BRACKET (FPI032) IN 6 LH POSITIONS WITH 2 OFF M4 X 10 SCREWS (SC0176) SUPPLIED WITH BRACKET. ALTERNATIVELY AN FPI032 CAN BE MOUNTED IN THE RH POSITION WITH 2 OFF PK 6 X 3/8" SCREWS (SC0090) USING 2 OFF Ø3.00 HOLES PROVIDED IN GEAR PLATE.

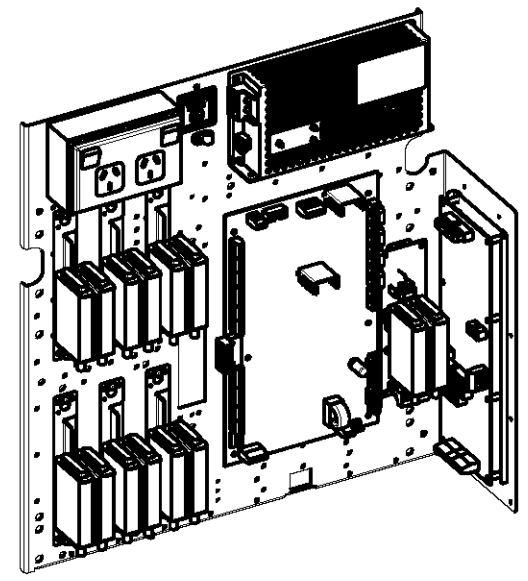

ISOMETRIC VIEW
SCALE 0.200

CONFIDENTIAL: THIS DOCUMENT MUST NOT BE COPIED NOR THE CONTENTS PASSED ON TO ANY THIRD PARTY WITHOUT THE CONSENT OF THE COMPANY.

UNLESS OTHERWISE STATED: ALL DIMENSIONS IN MILLIMETRES. DO NOT SCALE. TOLERANCES ARE TO BE: 1 DECIMAL PLACE ±0.5, 2 DECIMAL PLACES ±0.3, 3 DECIMAL PLACES ±0.1

3rd ANGLE PROJECTION

ISS/REV	AMENDMENTS	ECO	DRN	CHKD	AUTH	APVD	DATE
A	ORIGINAL	4167	KJS	LSC	RC	DP	20-08-10
B	3 X GENERAL PURPOSE RELAY BOARDS ADDED.	4270	KJS	GEL	LSC	DP	19-05-11
C	3 X G P RELAY BRDS REMOVED, 7 X FIBRE OPTIC MODEMS ADDED	-	KJS	HW	RC	DP	11-4-13

tyco
Fire Protection Products
TYCO FIRE PROTECTION PRODUCTS
17 MARY MULLER DRIVE
P.O. BOX 19545
CHRISTCHURCH, PH: +64 3 3895096
NEW ZEALAND. FAX: +64 3 3895938

MX1
I-HUB / FIBRE OPTIC MODEMS
GEARPLATE POSITIONS

DRAWING No: **1982-71** SHEET **149** of **N**

A3	ISS/REV C	PART No:
-----------	------------------	----------

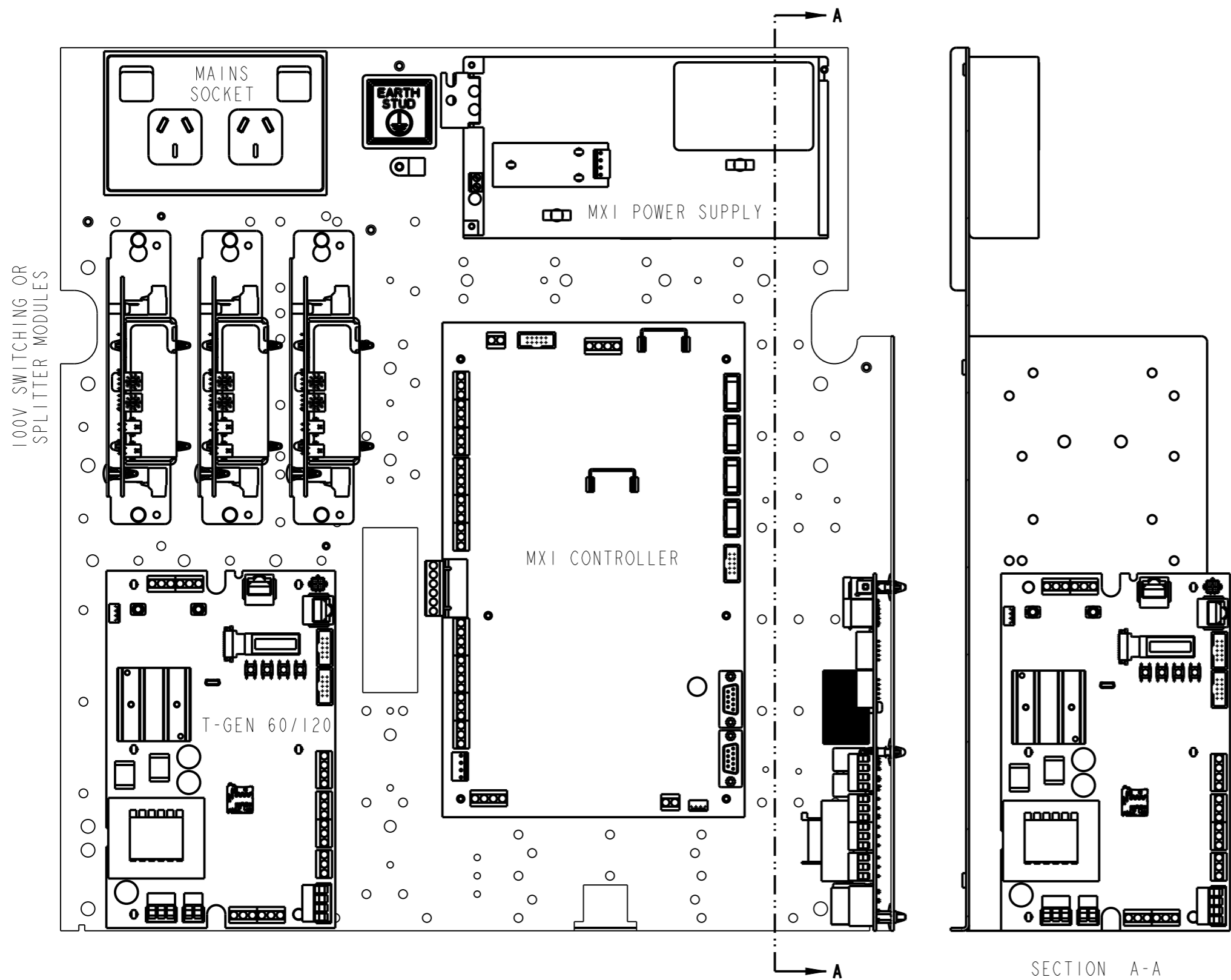

NOTES:

1. MOUNT T-GEN 60 USING 5 PLASTIC STAND-OFFS (HW0130) AND 1 OFF M3 X12 SCREW (SC0177). STAND-OFFS FACTORY FITTED FROM GEAR PLATE REAR.
2. MOUNT T-GEN 60 ON SIDE FLANGE USING 2 OFF M3 M/F BARREL NUTS (FA2552) AND 2 OFF M3 X 6 SCREWS (SC0172) FITTED TO J19 AND J26. 4 PLASTIC DOUBLE BARB PCB STAND-OFFS (HW0052) ARE FITTED TO THE 4 REMAINING HOLES. BARREL NUTS AND PLASTIC DOUBLE BARB PCB STAND-OFFS ARE FITTED FROM SIDE FLANGE FRONT.
3. MOUNT T-GEN 120 WITH 4 OFF M4 X10 SCREWS (SC0176) USING M4 LOOP CARD BRACKET MOUNTING HOLES IN GEAR PLATE.
4. MOUNT EACH 100V SWITCHING OR SPLITTER MODULE WITH 2 OFF M4 X10 SCREWS (SC0176) USING M4 LOOP CARD BRACKET MOUNTING HOLES IN GEAR PLATE.

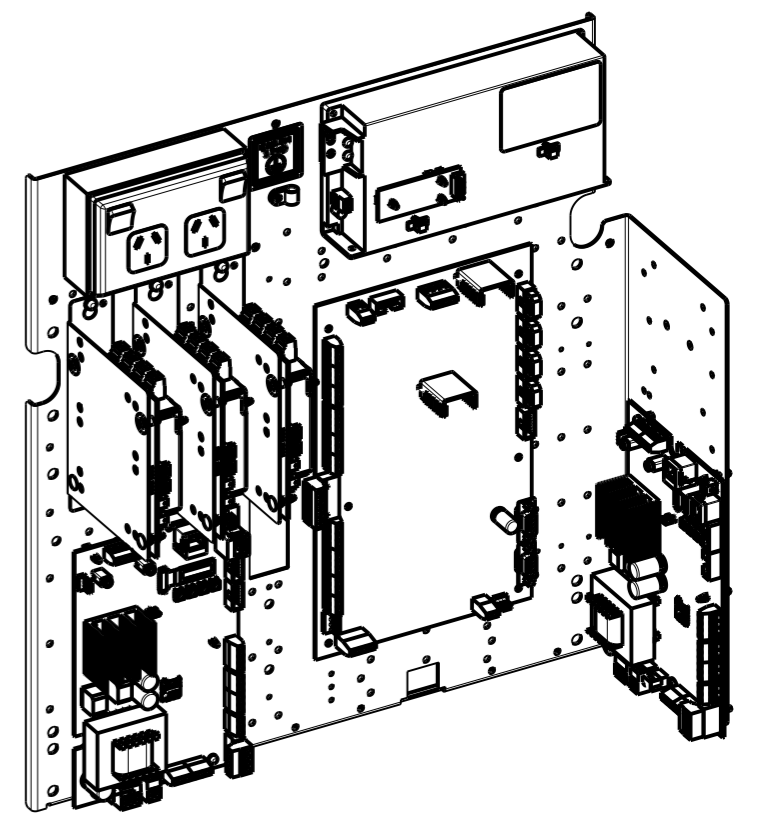

ISOMETRIC VIEW
SCALE 0.200

SECTION A-A

CONFIDENTIAL. THIS DOCUMENT MUST NOT BE COPIED NOR THE CONTENTS PASSED ON TO ANY THIRD PARTY WITHOUT THE CONSENT OF THE COMPANY.

UNLESS OTHERWISE STATED: ALL DIMENSIONS IN MILLIMETRES. DO NOT SCALE. TOLERANCES ARE TO BE: 1 DECIMAL PLACE ±0.5, 2 DECIMAL PLACES ±0.3, 3 DECIMAL PLACES ±0.1

3rd ANGLE PROJECTION

ISS/REV	AMENDMENTS	ECO	DRN	CHKD	AUTH	APVD	DATE
A	ORIGINAL	5053	KJS	RC	RC	DC	9-8-17
B	T-GEN 60 SIDE FOLD MTG ADDED.	5142	KJS	PV	RC	DC	15-10-18

© 2017 Johnson Controls. All rights reserved. All specifications and other information shown were current as of document revision date and are subject to change without notice.

JOHNSON CONTROLS
17 MARY MULLER DRIVE
P.O. BOX 19545
CHRISTCHURCH, PH: +64 3 3895096
NEW ZEALAND. FAX: +64 3 3895938

MX1
T-GEN2, 100V SWITCH/SPLITTER
GEARPLATE POSITIONS

DRAWING No: **1982-71** SHEET **169** of **N**

A3	ISS/REV B	PART No:
-----------	------------------	----------

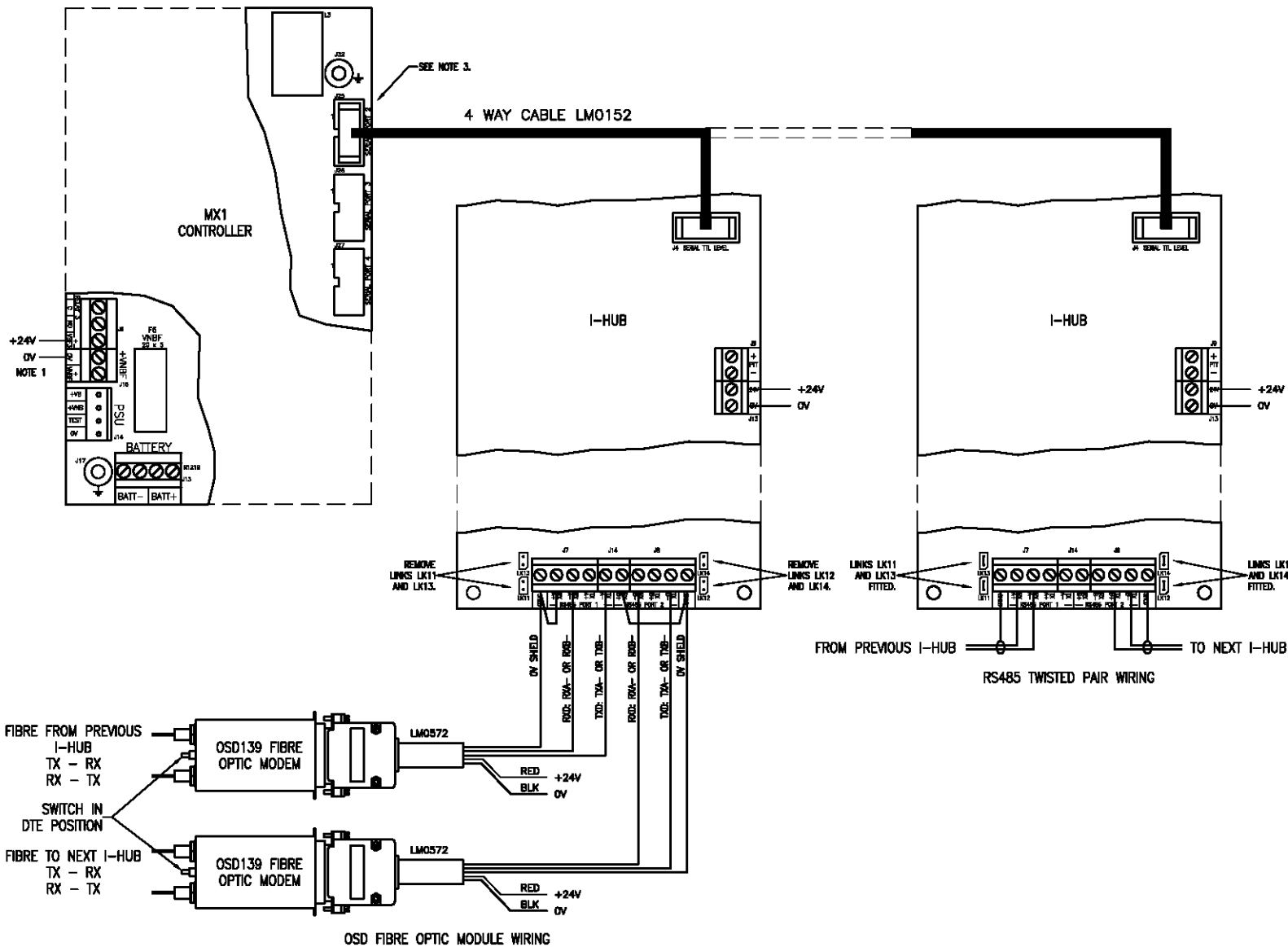

- NOTES:**
- +VBF SOURCE ON MX1 SHOULD BE FOR INTERNAL EQUIPMENT ONLY.
 - WIRING WILL DEPEND ON MEDIA USED ON EACH RING PORT.
- RS485 TWISTED PAIR RING**
- PORT 1**
FIT LINKS LK11 AND LK13.
WIRE RXA+, RXA- TO TXB+, TXB- ON PREVIOUS I-HUB.
- PORT 2**
FIT LINKS LK12 AND LK14.
WIRE TXB+, TXB- TO RXA+, RXA- ON NEXT I-HUB.
- FIBRE OPTIC RING**
- CUT THE 10 WAY CONNECTOR OFF THE END OF EACH LM0572.
- PORT 1**
REMOVE LINKS LK11 AND LK13.
WIRE LM0572 0V-SHIELD TO I-HUB SHIELD,
WIRE LM0572 RXD TO I-HUB RXA-,
WIRE LM0572 TXD TO I-HUB TXA-,
WIRE I-HUB SHIELD TO I-HUB RXA+.
- PORT 2**
REMOVE LINKS LK12 AND LK14.
WIRE LM0572 0V-SHIELD TO I-HUB SHIELD,
WIRE LM0572 RXD TO I-HUB RXB-,
WIRE LM0572 TXD TO I-HUB TXB-,
WIRE I-HUB SHIELD TO I-HUB RXB+.
3. SERIAL PORT 0, 2, 3 OR 4 USE MUST MATCH MX1 CONFIGURATION.

CONFIDENTIAL: THIS DOCUMENT MUST NOT BE COPIED NOR THE CONTENTS PASSED ON TO ANY THIRD PARTY WITHOUT THE CONSENT OF THE COMPANY.

UNLESS OTHERWISE STATED: ALL DIMENSIONS IN MILLIMETRES. DO NOT SCALE. TOLERANCES ARE TO BE: 1 DECIMAL PLACE ±0.5, 2 DECIMAL PLACES ±0.3, 3 DECIMAL PLACES ±0.1

3rd ANGLE PROJECTION

ISS/REV	AMENDMENTS	ECO	DRN	CHKD	AUTH	APVD	DATE
A	ORIGINAL	-	KJS	RC	RC	DP	15-4-13
B	LM0152 WAS 10W FRC LM0172	4608	KJS	GEL	LSC	DP	2-4-14

tyco
Fire Protection Products

TYCO FIRE PROTECTION PRODUCTS
17 MARY MULLER DRIVE
P.O. BOX 19545
CHRISTCHURCH, PH: +64 3 3895096
NEW ZEALAND. FAX: +64 3 3895938

MX1
I-HUB RS485 / FIBRE RING NETWORKING
WIRING DETAILS

DRAWING No: 1982-71 SHEET 150 of N

A3	ISS/REV B	PART No:
----	-----------	----------

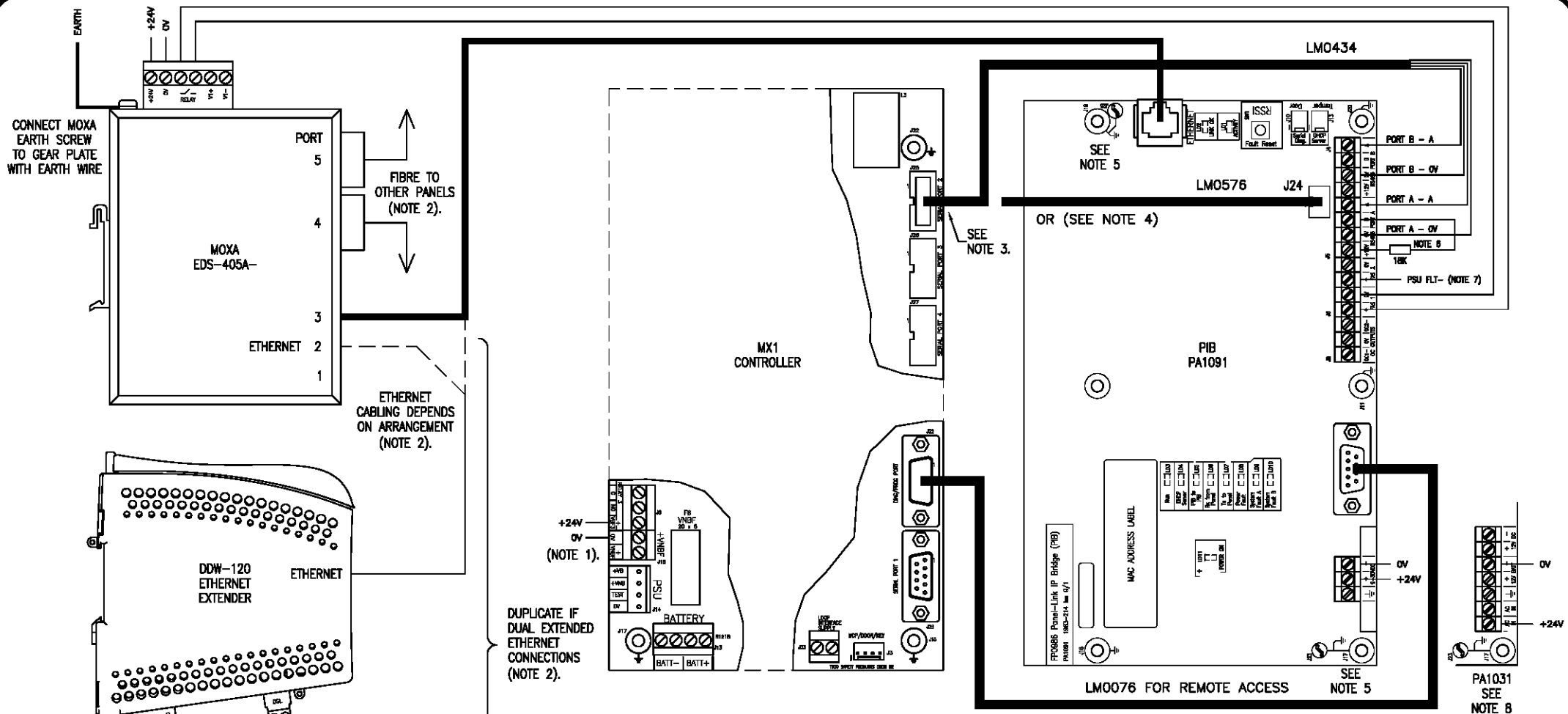

- NOTES:**
- +VBF SOURCE ON MX1 SHOULD BE FOR NETWORKING EQUIPMENT ONLY (PIB, MOXA, ETH EXTENDER).
 - ETHERNET CABLING AND PORTS USED ON MOXA EDS-405A WILL DEPEND ON REQUIREMENTS.
 - IS MOXA EDS-405A- FITTED?
 - IS NETWORK SINGLE PATH/RING?
 - IS RING USING FIBRE/ETHERNET/EXTENDED ETHERNET?
 - HOW MANY DDW-120 ARE FITTED, 0/1/2?
 - SERIAL PORT 0, 2, 3 OR 4 USE MUST MATCH MX1 CONFIGURATION.
 - PIB CONNECTION: LM0576 - PLUG INTO J24 ON ISSUE G AND ONWARDS PIB, OR LM0434 - WIRE AS INDICATED ON ISSUE G AND EARLIER PIB.
 - PIB MUST BE EARTHED TO GEAR PLATE VIA J17 AND J19 (METAL SCREWS) OR EARTH LEAD ON J23 AND J25.
 - FOR PA1031 PIB, UP TO REV 7, FIT 18K RESISTOR BETWEEN +12V AND B TERMINALS. NOT REQUIRED FOR PA1091 PIB, OR PA1031 REV 8.
 - FIT POWER SUPPLY FAULT- SIGNAL TO FAS2 IF POWER SUPPLY FAULT MONITORING BY PIB IS REQUIRED (PA1091 ONLY).
 - POWER SUPPLY WIRING DETAILS FOR PA1031 PIB.

CONFIDENTIAL: THIS DOCUMENT MUST NOT BE COPIED NOR THE CONTENTS PASSED ON TO ANY THIRD PARTY WITHOUT THE CONSENT OF THE COMPANY.

UNLESS OTHERWISE STATED: ALL DIMENSIONS IN MILLIMETRES. DO NOT SCALE. TOLERANCES ARE TO BE: 1 DECIMAL PLACE ±0.5, 2 DECIMAL PLACES ±0.3, 3 DECIMAL PLACES ±0.1

3rd ANGLE PROJECTION

ISS/REV	AMENDMENTS	ECO	DRN	CHKD	AUTH	APVD	DATE
A	ORIGINAL	4476	KJS	RC	RC	DP	15-4-13

tyco
Fire Protection Products

TYCO FIRE PROTECTION PRODUCTS
17 MARY MULLER DRIVE
P.O. BOX 18545
CHRISTCHURCH, PH: +64 3 3895096
NEW ZEALAND. FAX: +64 3 3895938

**MX1
IP NETWORKING
WIRING DETAILS**

DRAWING No: 1982-71 SHEET 151 of N

A3	ISS/REV A	PART No:	
----	-----------	----------	--

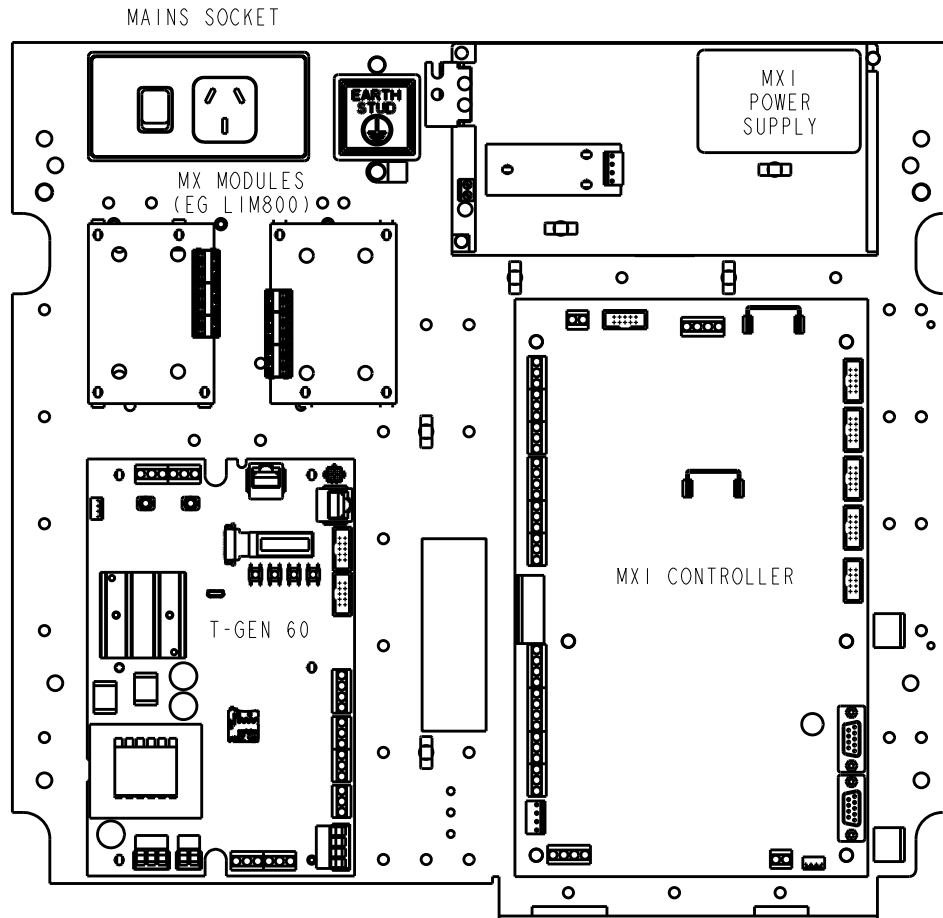

NOTES:

1. MOUNT T-GEN 60 USING 5 PLASTIC STAND-OFFS (HW0130) AND 1 OFF M3 X12 SCREW (SC0177). STAND-OFFS FACTORY FITTED FROM GEAR PLATE REAR.
2. MOUNT MX MODULES USING 4 PLASTIC DOUBLE BARB PCB STAND-OFFS (HW0052) FITTED FROM FRONT OF GEAR PLATE.

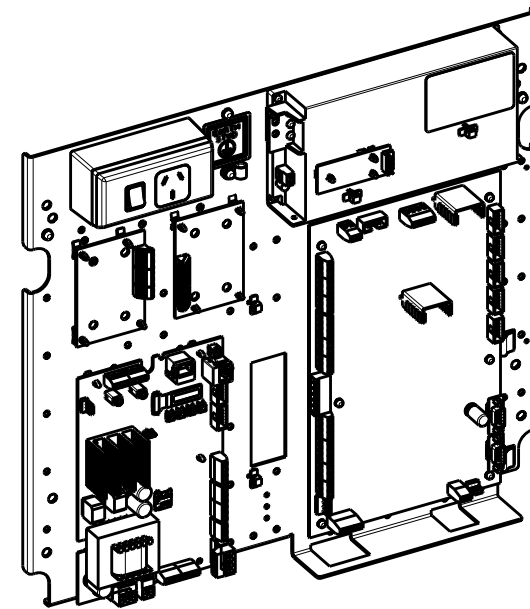

ISOMETRIC VIEW
SCALE 0.250

CONFIDENTIAL: THIS DOCUMENT MUST NOT BE COPIED NOR THE CONTENTS PASSED ON TO ANY THIRD PARTY WITHOUT THE CONSENT OF THE COMPANY.

UNLESS OTHERWISE STATED: ALL DIMENSIONS IN MILLIMETRES. DO NOT SCALE. TOLERANCES ARE TO BE: 1 DECIMAL PLACE ± 0.5 , 2 DECIMAL PLACES ± 0.3 , 3 DECIMAL PLACES ± 0.1

3rd ANGLE PROJECTION

ISS/REV	AMENDMENTS	ECO	DRN	CHKD	AUTH	APVD	DATE
A	ORIGINAL	-	KJS	RC	RC	RC	03-09-13
B	UPDATED FOR T-GEN 60.	5053	KJS	RC	RC	DC	8-9-17

© 2017 Johnson Controls. All rights reserved.
All specifications and other information shown were current as of document revision date and are subject to change without notice.

JOHNSON CONTROLS
17 MARY MULLER DRIVE
P.O. BOX 19545
CHRISTCHURCH, PH: +64 3 3895096
NEW ZEALAND. FAX: +64 3 3895938

MX1	
T-GEN 60, MX MODULES	
8U GEARPLATE POSITIONS	
DRAWING No: 1982-71 SHEET 152 of N	
A3	ISS/REV B PART No:

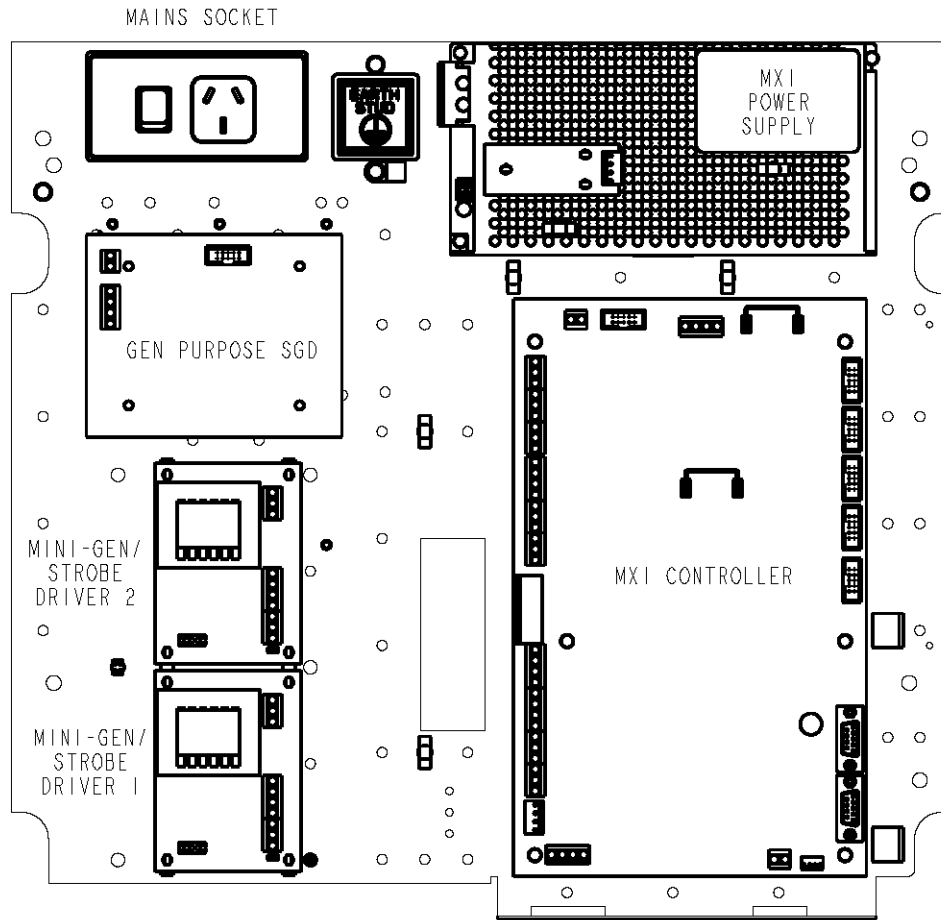

NOTES:

1. MOUNT MINI-GEN OR STROBE DRIVERS USING 4 PLASTIC DOUBLE BARB PCB STAND-OFFS (HW0052) FITTED FROM FRONT OF GEAR PLATE.
2. EARTH MINI-GEN OR STROBE DRIVER TO GEAR PLATE EARTH POINT USING EARTH LEAD, (E.G. LM0231 INCLUDED IN MX1).
3. MOUNT A GENERAL PURPOSE SGD (PA0862) USING 4 PLASTIC DOUBLE BARB PCB STAND-OFFS (HW0053) FITTED FROM GEAR PLATE FRONT.

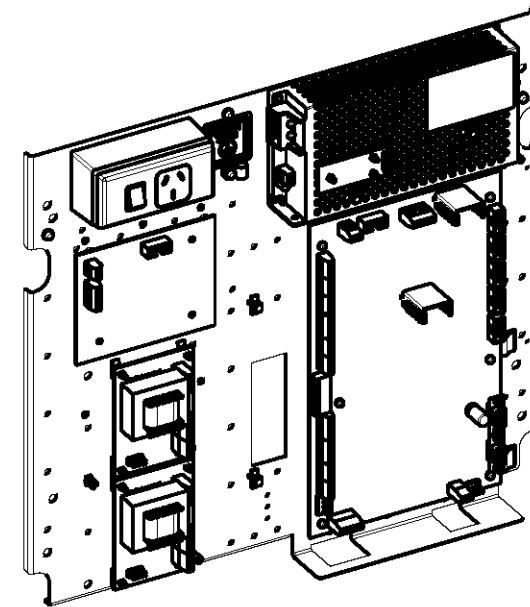

ISOMETRIC VIEW
SCALE 0.250

CONFIDENTIAL: THIS DOCUMENT MUST NOT BE COPIED NOR THE CONTENTS PASSED ON TO ANY THIRD PARTY WITHOUT THE CONSENT OF THE COMPANY.

UNLESS OTHERWISE STATED: ALL DIMENSIONS IN MILLIMETRES. DO NOT SCALE. TOLERANCES ARE TO BE: 1 DECIMAL PLACE ± 0.5 , 2 DECIMAL PLACES ± 0.3 , 3 DECIMAL PLACES ± 0.1

3rd ANGLE PROJECTION

ISS/REV	AMENDMENTS	ECO	DRN	CHKD	AUTH	APVD	DATE
A	ORIGINAL	-	KJS	RC	RC	DP	03-09-13
B	NOTE 1 UPDATED. MINI-GENS MOVED 10mm TO LEFT.	4570	KJS	GEL	LSC	DP	2-12-13

tyco
Fire Protection Products
TYCO FIRE PROTECTION PRODUCTS
17 MARY MULLER DRIVE
P.O. BOX 19545
CHRISTCHURCH, PH: +64 3 3895096
NEW ZEALAND. FAX: +64 3 3895938

MX1
SGD, MINI-GEN / STROBE
8U GEARPLATE POSITIONS

DRAWING No: **1982-71** SHEET **153** of **N**

A3	ISS/REV B	PART No:
-----------	------------------	----------

MAINS SOCKET

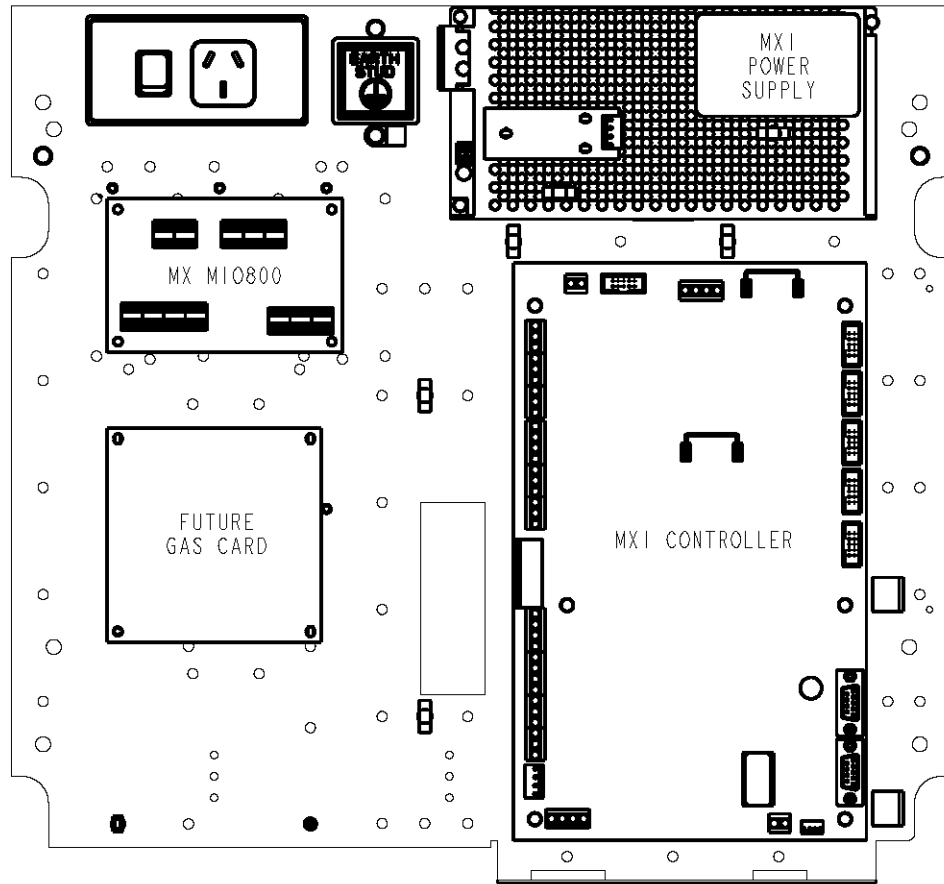

NOTES:

1. MOUNT MX MIO800 MODULE USING 4 PLASTIC DOUBLE BARB PCB STAND-OFFS (HW0052) FITTED FROM FRONT OF GEAR PLATE.
2. HOLES PROVIDED FOR MOUNTING THE FUTURE GAS CARD USING 4 PLASTIC DOUBLE BARB PCB STAND-OFFS (HW0052) FITTED FROM FRONT OF GEAR PLATE.

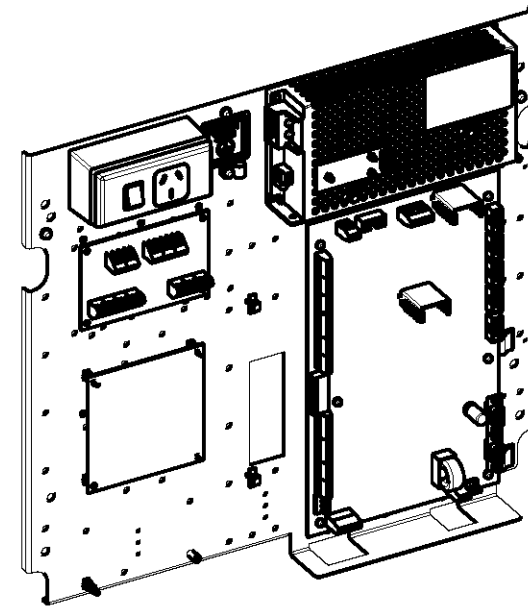

ISOMETRIC VIEW
SCALE 0.250

CONFIDENTIAL: THIS DOCUMENT MUST NOT BE COPIED NOR THE CONTENTS PASSED ON TO ANY THIRD PARTY WITHOUT THE CONSENT OF THE COMPANY.

UNLESS OTHERWISE STATED: ALL DIMENSIONS IN MILLIMETRES. DO NOT SCALE. TOLERANCES ARE TO BE: 1 DECIMAL PLACE ± 0.5 , 2 DECIMAL PLACES ± 0.3 , 3 DECIMAL PLACES ± 0.1

3rd ANGLE PROJECTION

ISS/REV	AMENDMENTS	ECO	DRN	CHKD	AUTH	APVD	DATE
A	ORIGINAL	-	KJS	RC	RC	DP	03-09-13

tyco
Fire Protection Products
TYCO FIRE PROTECTION PRODUCTS
17 MARY MULLER DRIVE
P.O. BOX 19545
CHRISTCHURCH, PH: +64 3 3895096
NEW ZEALAND. FAX: +64 3 3895938

MX1
MIO800, FUTURE GAS CARD
8U GEARPLATE POSITIONS

DRAWING No: **1982-71** SHEET **154** of **N**

A3	ISS/REV A	PART No:
-----------	------------------	----------

MAINS SOCKET

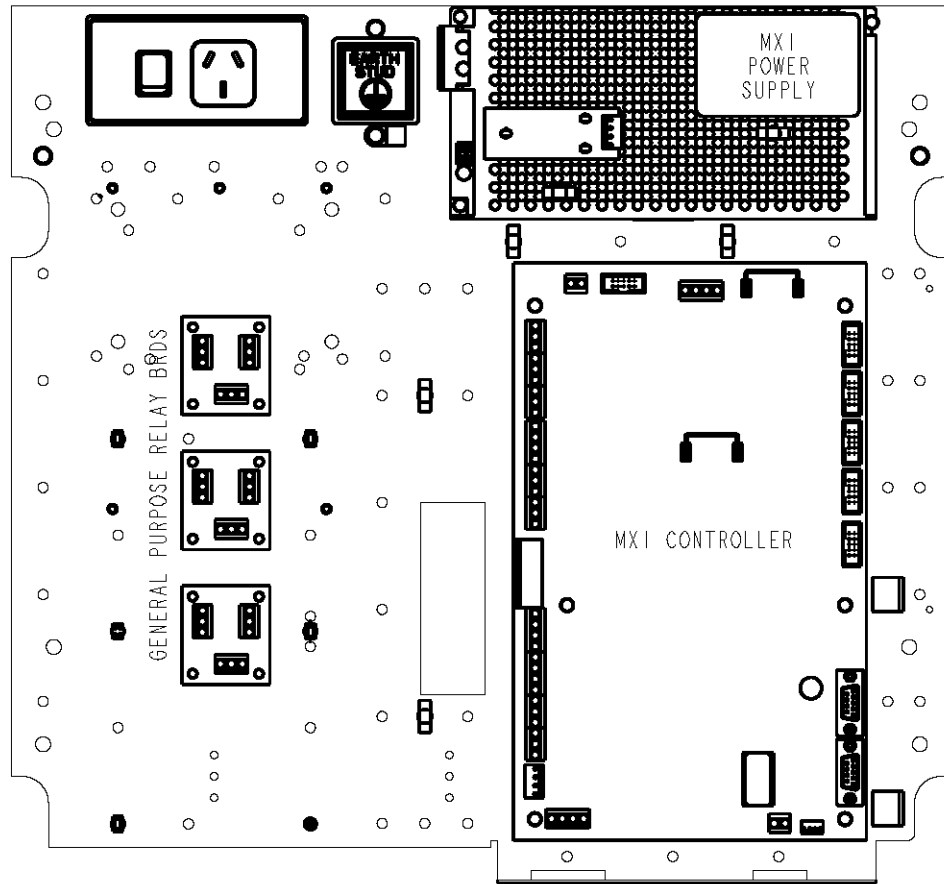

NOTES:

1. MOUNT GENERAL PURPOSE RELAY BOARDS (PA0730) USING 4 PLASTIC DOUBLE BARB PCB STAND-OFFS (HW0052) PER BOARD, FITTED FROM FRONT OF GEAR PLATE.

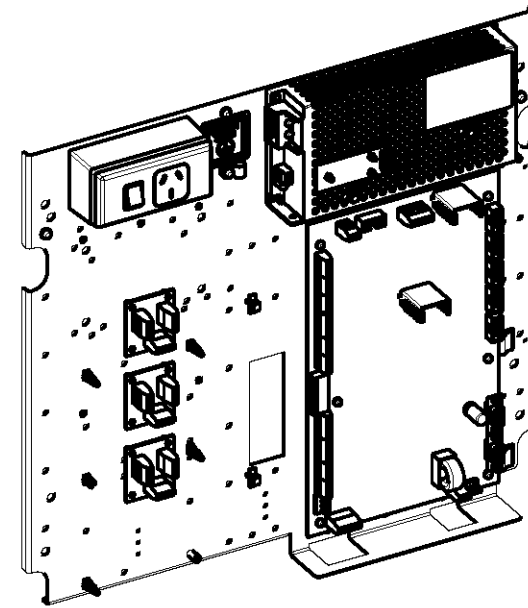

ISOMETRIC VIEW
SCALE 0.250

CONFIDENTIAL: THIS DOCUMENT MUST NOT BE COPIED NOR THE CONTENTS PASSED ON TO ANY THIRD PARTY WITHOUT THE CONSENT OF THE COMPANY.

UNLESS OTHERWISE STATED: ALL DIMENSIONS IN MILLIMETRES. DO NOT SCALE. TOLERANCES ARE TO BE:
1 DECIMAL PLACE ± 0.5 , 2 DECIMAL PLACES ± 0.3 , 3 DECIMAL PLACES ± 0.1

3rd ANGLE PROJECTION

ISS/REV	AMENDMENTS	ECO	DRN	CHKD	AUTH	APVD	DATE
A	ORIGINAL	-	KJS	RC	RC	DP	03-09-13

tyco
Fire Protection Products
TYCO FIRE PROTECTION PRODUCTS
17 MARY MULLER DRIVE
P.O. BOX 19545
CHRISTCHURCH, PH: +64 3 3895096
NEW ZEALAND. FAX: +64 3 3895938

**MX1
GEN PURPOSE RELAY
8U GEARPLATE POSITIONS**

DRAWING No: **1982-71** SHEET **155** of **N**

A3	ISS/REV A	PART No:
-----------	------------------	----------

MAINS SOCKET

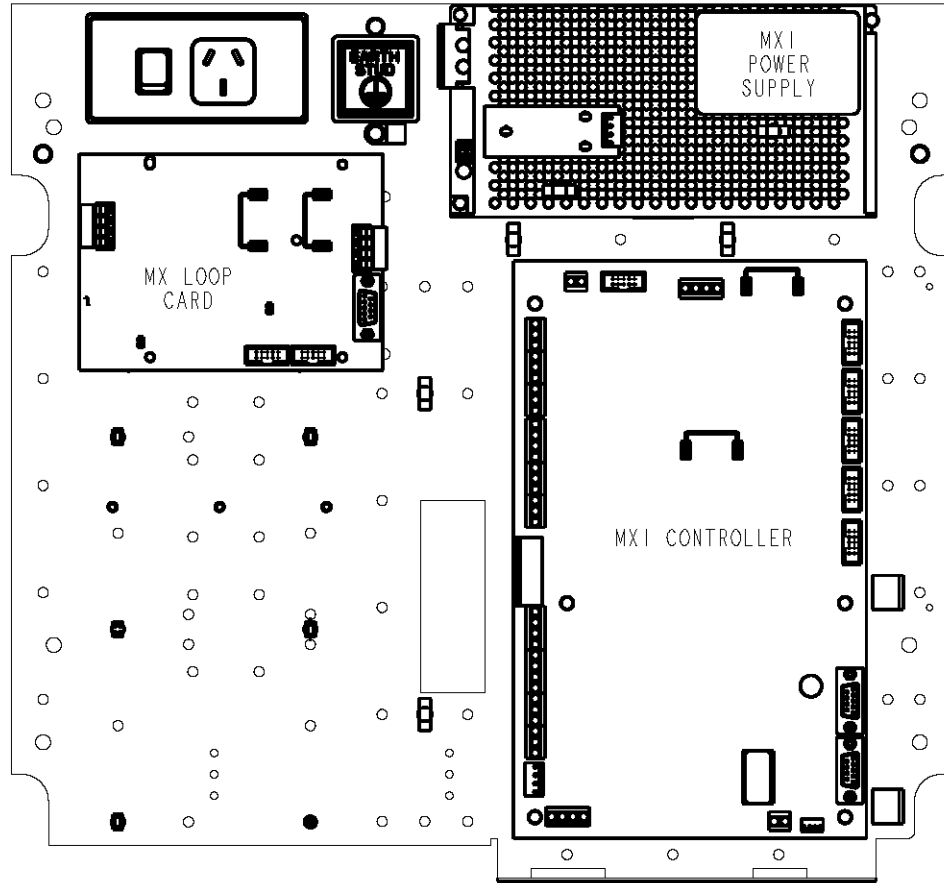

NOTES:

1. MOUNT MXI LOOP CARD USING 4 PLASTIC DOUBLE BARB PCB STAND-OFFS (HW0052) FITTED FROM FRONT OF GEAR PLATE.

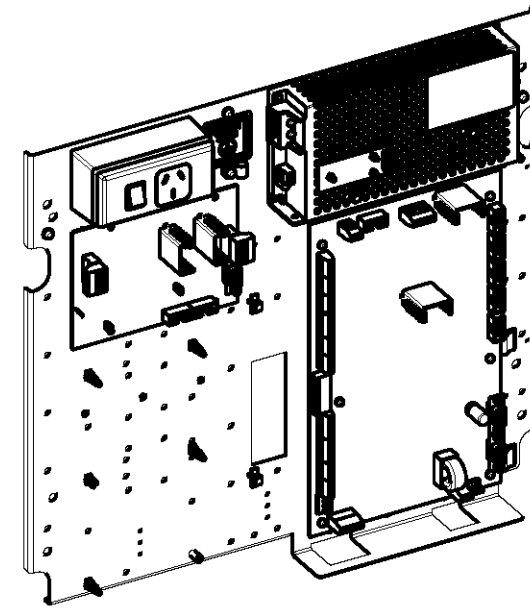

ISOMETRIC VIEW
SCALE 0.250

CONFIDENTIAL: THIS DOCUMENT MUST NOT BE COPIED NOR THE CONTENTS PASSED ON TO ANY THIRD PARTY WITHOUT THE CONSENT OF THE COMPANY.

UNLESS OTHERWISE STATED: ALL DIMENSIONS IN MILLIMETRES. DO NOT SCALE. TOLERANCES ARE TO BE: 1 DECIMAL PLACE ± 0.5 , 2 DECIMAL PLACES ± 0.3 , 3 DECIMAL PLACES ± 0.1

3rd ANGLE PROJECTION

ISS/REV	AMENDMENTS	ECO	DRN	CHKD	AUTH	APVD	DATE
A	ORIGINAL	-	KJS	RC	RC	DP	03-09-13

tyco
Fire Protection Products
TYCO FIRE PROTECTION PRODUCTS
17 MARY MULLER DRIVE
P.O. BOX 19545
CHRISTCHURCH, PH: +64 3 3895096
NEW ZEALAND. FAX: +64 3 3895938

**MX1
MX LOOP CARD
8U GEARPLATE POSITIONS**

DRAWING No: **1982-71** SHEET **156** of **N**

A3	ISS/REV A	PART No:
-----------	------------------	----------

NOTES:

1. MOUNT EACH BRACKET (FPI044, FP0950, FPI027) WITH 2 OFF M4 X 10 SCREWS (SC0176). SCREWS FITTED FROM GEAR PLATE FRONT.
2. MOUNT MX MODULES ON FPI027 BRACKET USING 4 PLASTIC PCB STAND-OFFS (HW0131) PROVIDED WITH BRACKET.
3. MOUNT MINI-GEN OR STROBE DRIVER USING 4 PLASTIC DOUBLE BARB PCB STAND-OFFS (HW0052) FITTED FROM FRONT OF GEAR PLATE.
4. EARTH EACH MINI-GEN OR STROBE DRIVER TO A GEAR PLATE EARTH POINT USING EARTH LEAD, (E.G. LM0231 INCLUDED IN MX1).

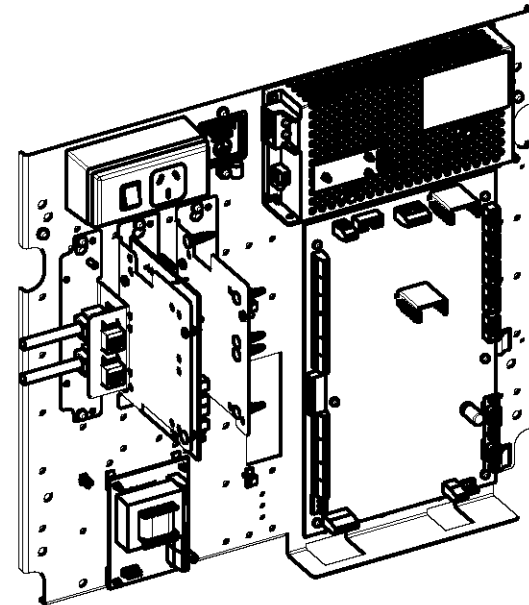
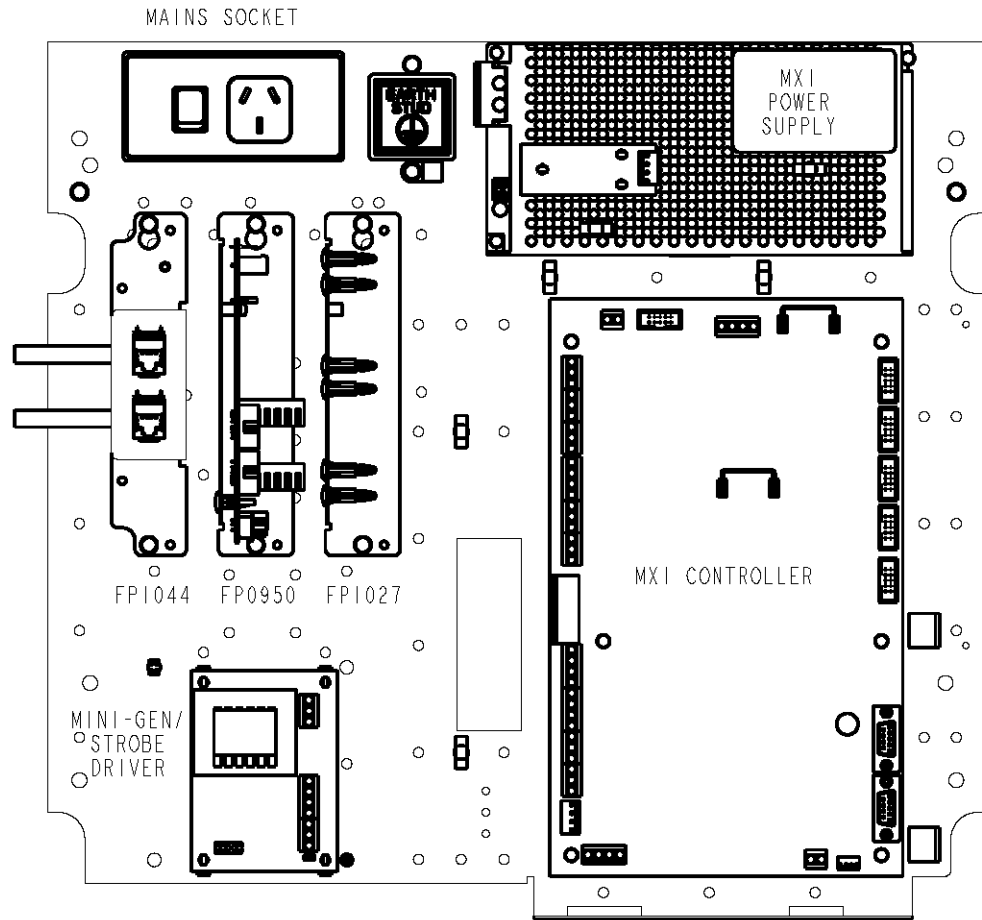

ISOMETRIC VIEW
SCALE 0.250

CONFIDENTIAL: THIS DOCUMENT MUST NOT BE COPIED NOR THE CONTENTS PASSED ON TO ANY THIRD PARTY WITHOUT THE CONSENT OF THE COMPANY.

UNLESS OTHERWISE STATED: ALL DIMENSIONS IN MILLIMETRES. DO NOT SCALE. TOLERANCES ARE TO BE: 1 DECIMAL PLACE ± 0.5 , 2 DECIMAL PLACES ± 0.3 , 3 DECIMAL PLACES ± 0.1

3rd ANGLE PROJECTION

ISS/REV	AMENDMENTS	ECO	DRN	CHKD	AUTH	APVD	DATE
A	ORIGINAL	-	KJS	RC	RC	DP	03-09-13
B	NOTE 3 UPDATED. MINI-GEN MOVED 10mm TO LEFT.	4570	KJS	GEL	LSC	DP	3-12-13

tyco
Fire Protection Products
TYCO FIRE PROTECTION PRODUCTS
17 MARY MULLER DRIVE
P.O. BOX 19545
CHRISTCHURCH, PH: +64 3 3895096
NEW ZEALAND. FAX: +64 3 3895938

MX1
STP BKT, LOOP CD BKT, MX MOD
8U GEARPLATE POSITIONS

DRAWING No: **1982-71** SHEET **157** of **N**

A3	ISS/REV B	PART No:
-----------	------------------	----------

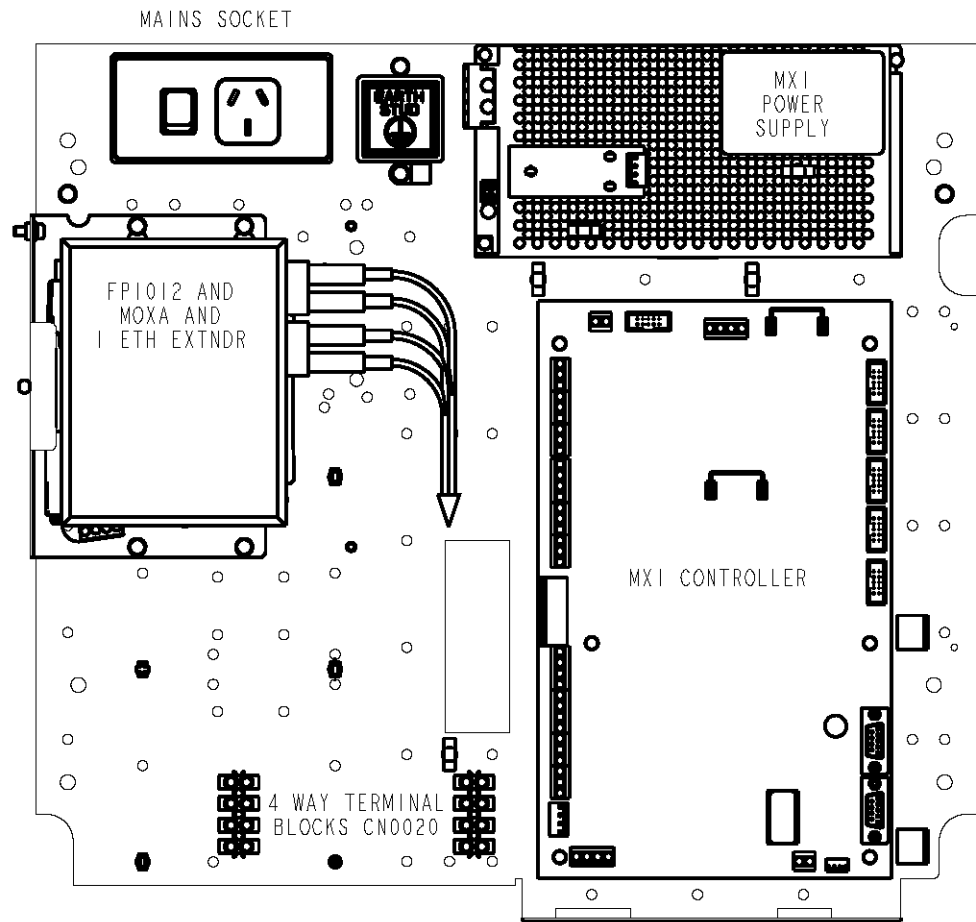

NOTES:

1. MOUNT THE FPI012 BRACKET TO THE GEAR PLATE WITH 4 OFF M4 X 10 SCREWS (SC0176). SCREWS FITTED FROM GEAR PLATE FRONT.
2. THE MOXA SWITCH AND ETHERNET EXTENDER CLIP ONTO THE DIN RAIL ON THE FPI012 BRACKET. MOUNT MOXA CLOSEST TO GEAR PLATE. LEAVE A 10mm GAP EACH SIDE OF ETH EXTENDER FOR COOLING. CONNECT THE MOXA EARTH SCREW TO THE BRACKET.
3. MOUNT THE 4 WAY TERMINAL BLOCKS CN0020 WITH 2 X 1/8" POP RIVETS HW0211.

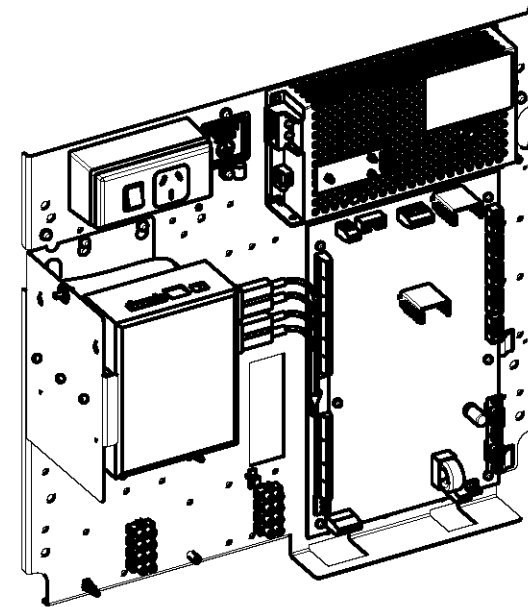

ISOMETRIC VIEW
SCALE 0.250

CONFIDENTIAL: THIS DOCUMENT MUST NOT BE COPIED NOR THE CONTENTS PASSED ON TO ANY THIRD PARTY WITHOUT THE CONSENT OF THE COMPANY.

UNLESS OTHERWISE STATED: ALL DIMENSIONS IN MILLIMETRES. DO NOT SCALE. TOLERANCES ARE TO BE: 1 DECIMAL PLACE ± 0.5 , 2 DECIMAL PLACES ± 0.3 , 3 DECIMAL PLACES ± 0.1

3rd ANGLE PROJECTION

ISS/REV	AMENDMENTS	ECO	DRN	CHKD	AUTH	APVD	DATE
A	ORIGINAL	-	KJS	RC	RC	DP	03-09-13

tyco
Fire Protection Products
TYCO FIRE PROTECTION PRODUCTS
17 MARY MULLER DRIVE
P.O. BOX 19545
CHRISTCHURCH, PH: +64 3 3895096
NEW ZEALAND. FAX: +64 3 3895938

MX1
FP1012, MOXA & EXTENDER
8U GEARPLATE POSITIONS

DRAWING No: **1982-71** SHEET **158** of **N**

A3	ISS/REV A	PART No:
-----------	------------------	----------

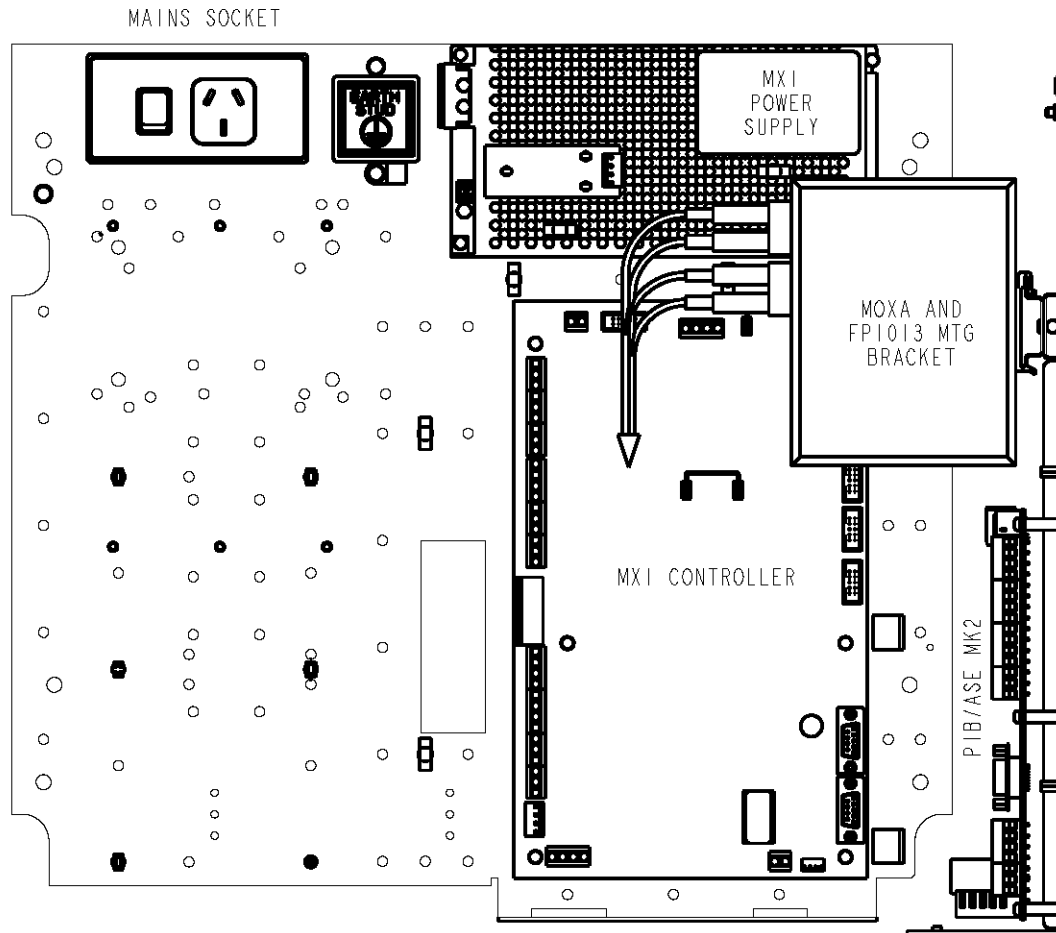

NOTES:

1. MOUNT THE IP NETWORKING BRACKET (FPI013) ON THE 8U CABINET RHS WALL 4 OFF M3 X 12 STUDS USING 4 OFF M3 X 10 BARREL NUTS (FA2016), M3 FLAT WASHERS (WA0005) AND M3 SHAKEPROOF WASHERS (WA0010).
2. ONLY A MOXA SWITCH CAN CLIP ONTO THE DIN RAIL ON THE FPI013 BRACKET. THERE IS INSUFFICIENT ROOM TO MOUNT AN ETHERNET EXTENDER. CONNECT THE MOXA EARTH SCREW TO THE BRACKET.
3. MOUNT THE PIB ON THE FPI013 BRACKET USING 6 OFF M3 X 6 SCREWS (SC0172)
4. ALL FASTENING HARDWARE IS SUPPLIED WITH FPI013.

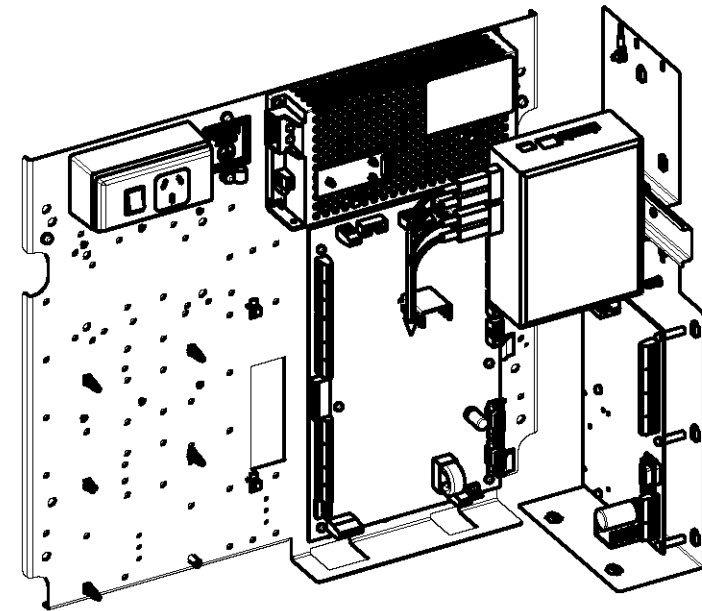

ISOMETRIC VIEW
SCALE 0.250

CONFIDENTIAL: THIS DOCUMENT MUST NOT BE COPIED NOR THE CONTENTS PASSED ON TO ANY THIRD PARTY WITHOUT THE CONSENT OF THE COMPANY.

UNLESS OTHERWISE STATED: ALL DIMENSIONS IN MILLIMETRES. DO NOT SCALE. TOLERANCES ARE TO BE: 1 DECIMAL PLACE ± 0.5 , 2 DECIMAL PLACES ± 0.3 , 3 DECIMAL PLACES ± 0.1

3rd ANGLE PROJECTION

ISS/REV	AMENDMENTS	ECO	DRN	CHKD	AUTH	APVD	DATE
A	ORIGINAL	-	KJS	RC	RC	RC	03-09-13

tyco
Fire Protection Products
TYCO FIRE PROTECTION PRODUCTS
17 MARY MULLER DRIVE
P.O. BOX 19545
CHRISTCHURCH, PH: +64 3 3895096
NEW ZEALAND. FAX: +64 3 3895938

MX1
FP1013, MOXA & EXTENDER
8U GEARPLATE POSITIONS

DRAWING No: **1982-71** SHEET **159** of **N**

A3	ISS/REV A	PART No:	
-----------	------------------	----------	--

MAINS SOCKET

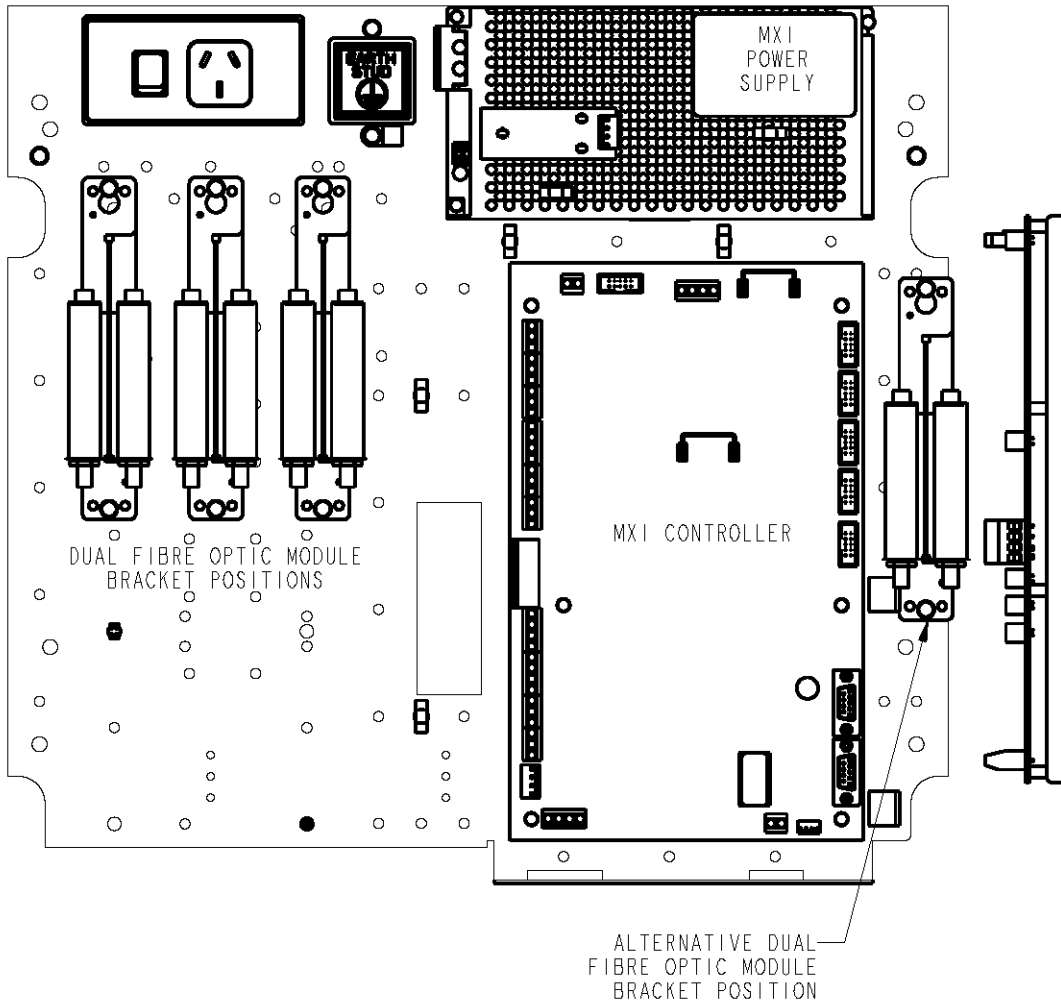

NOTES:

1. MOUNT THE ECM MOUNTING PLATE (FA2083) ON THE 8U CABINET RHS WALL 4 OFF M3 X 12 STUDS USING 4 OFF M3 X 10 BARREL NUTS (FA2016), M3 FLAT WASHERS (WA0005) AND M3 SHAKEPROOF WASHERS (WA0010). REMOUNT THE I-HUB ON THE MOUNTING PLATE (FA2083) WITH 8 OFF M3 X 6 SCREWS (SC0172).

2. MOUNT THE DUAL OSD139 FIBRE OPTIC MODEM MOUNTING BRACKET (FP1032) IN 3 LH POSITIONS WITH 2 OFF M4 X 10 SCREWS (SC0176) SUPPLIED WITH BRACKET.

ALTERNATIVELY AN FPI032 CAN BE MOUNTED IN THE RH POSITION WITH 2 OFF PK 6 X 3/8" SCREWS (SC0090) USING 2 OFF Ø3.00 HOLES PROVIDED IN THE GEAR PLATE.

I-HUB
(OR ECM
FOR PMB
OR TPI)

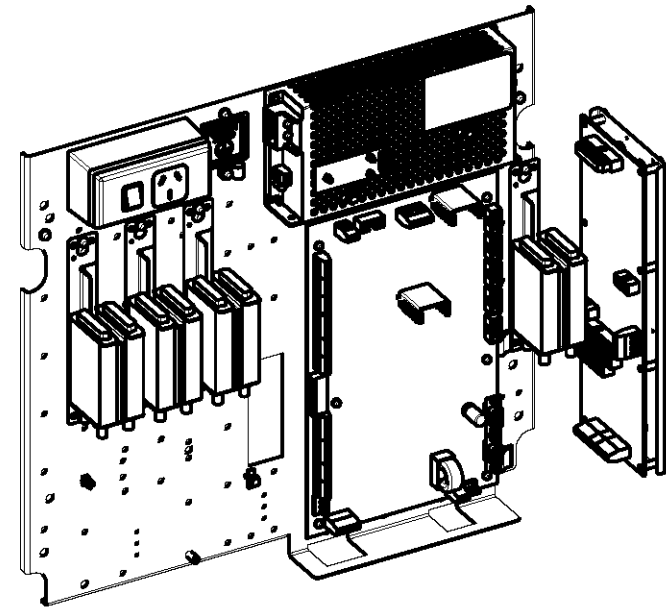

ISOMETRIC VIEW
SCALE 0.250

CONFIDENTIAL: THIS DOCUMENT MUST NOT BE COPIED NOR THE CONTENTS PASSED ON TO ANY THIRD PARTY WITHOUT THE CONSENT OF THE COMPANY.

UNLESS OTHERWISE STATED: ALL DIMENSIONS IN MILLIMETRES. DO NOT SCALE. TOLERANCES ARE TO BE: 1 DECIMAL PLACE ±0.5, 2 DECIMAL PLACES ±0.3, 3 DECIMAL PLACES ±0.1

3rd ANGLE PROJECTION

ISS/REV	AMENDMENTS	ECO	DRN	CHKD	AUTH	APVD	DATE
A	ORIGINAL	-	KJS	RC	RC	DP	03-09-13

tyco
Fire Protection Products
TYCO FIRE PROTECTION PRODUCTS
17 MARY MULLER DRIVE
P.O. BOX 19545
CHRISTCHURCH, PH: +64 3 3895096
NEW ZEALAND. FAX: +64 3 3895938

MX1
I-HUB / FIBRE OPTIC MODEMS
8U GEARPLATE POSITIONS

DRAWING No: **1982-71** SHEET **160** of **N**

A3	ISS/REV A	PART No:	
-----------	------------------	----------	--

MX1 CONTROLLER

FAULT/DEF RELAY IS
NORMALLY ENERGISED

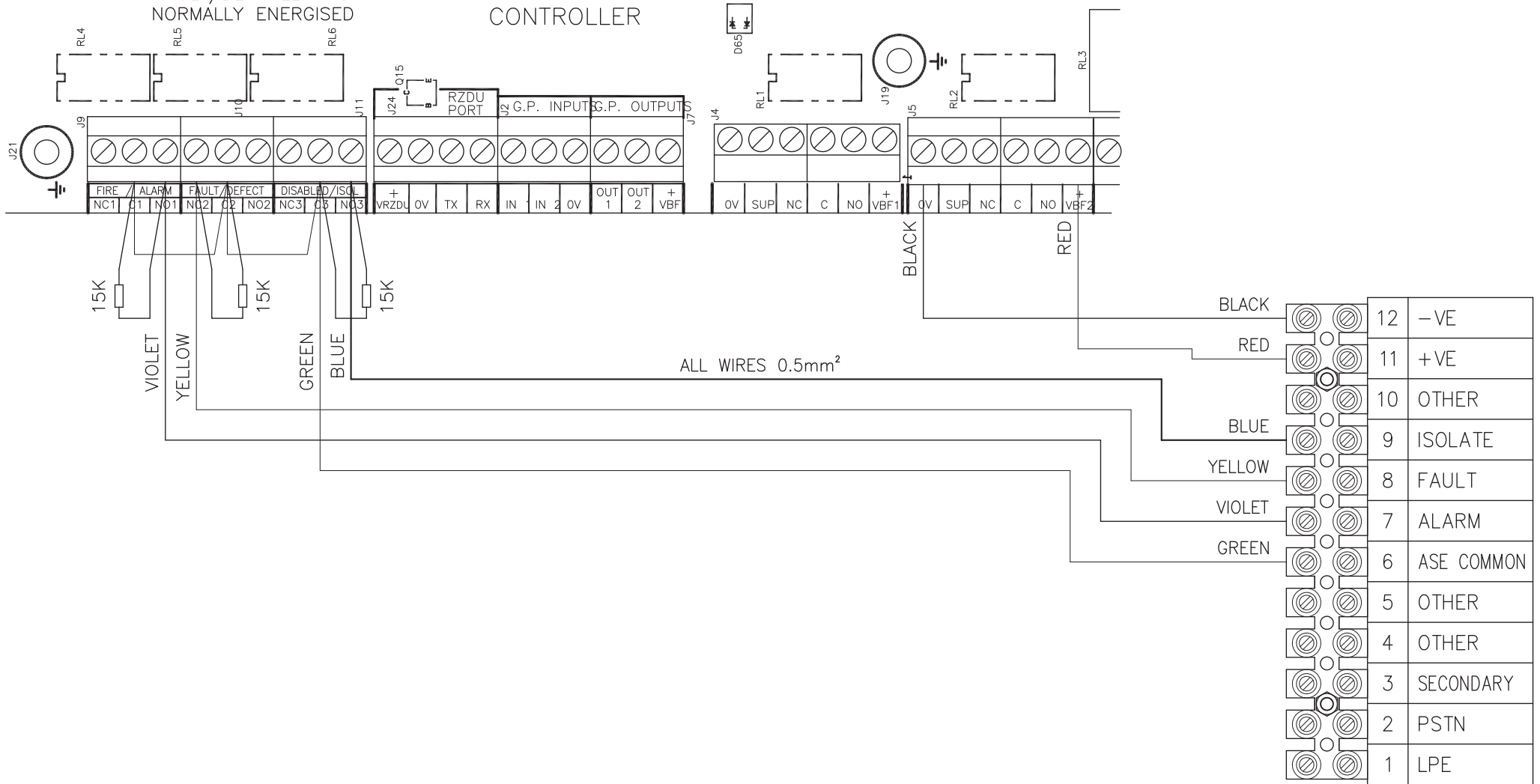

ALL WIRES 0.5mm²

TERMINAL BLOCK ON
BRACKET

CONFIDENTIAL: THIS DOCUMENT MUST NOT BE COPIED NOR THE CONTENTS PASSED ON TO ANY THIRD PARTY WITHOUT THE CONSENT OF THE COMPANY.

UNLESS OTHERWISE STATED: ALL DIMENSIONS IN MILLIMETRES. DO NOT SCALE. TOLERANCES ARE TO BE: 1 DECIMAL PLACE ±0.5, 2 DECIMAL PLACES ±0.3, 3 DECIMAL PLACES ±0.1

3rd ANGLE
PROJECTION

ISS/REV	AMENDMENTS	ECO	DRN	CHKD	AUTH	APVD	DATE
A	ORIGINAL	4011	KJS	GEL	LSC	DP	21-4-09
B	WIRING UPDATED FOR WA ASE.	ECS1604	KJS	RC	RC	DP	22-11-11

tyco
Fire Protection Products

TYCO FIRE PROTECTION PRODUCTS
17 MARY MULLER DRIVE
P.O. BOX 19545
CHRISTCHURCH, PH: +64 3 3895096
NEW ZEALAND. FAX: +64 3 3895938

**MX1
WA ASE
WIRING DETAILS**

DRAWING No: 1982-71 SHEET 145 of N

A3	ISS/REV	B	PART No:
----	---------	---	----------

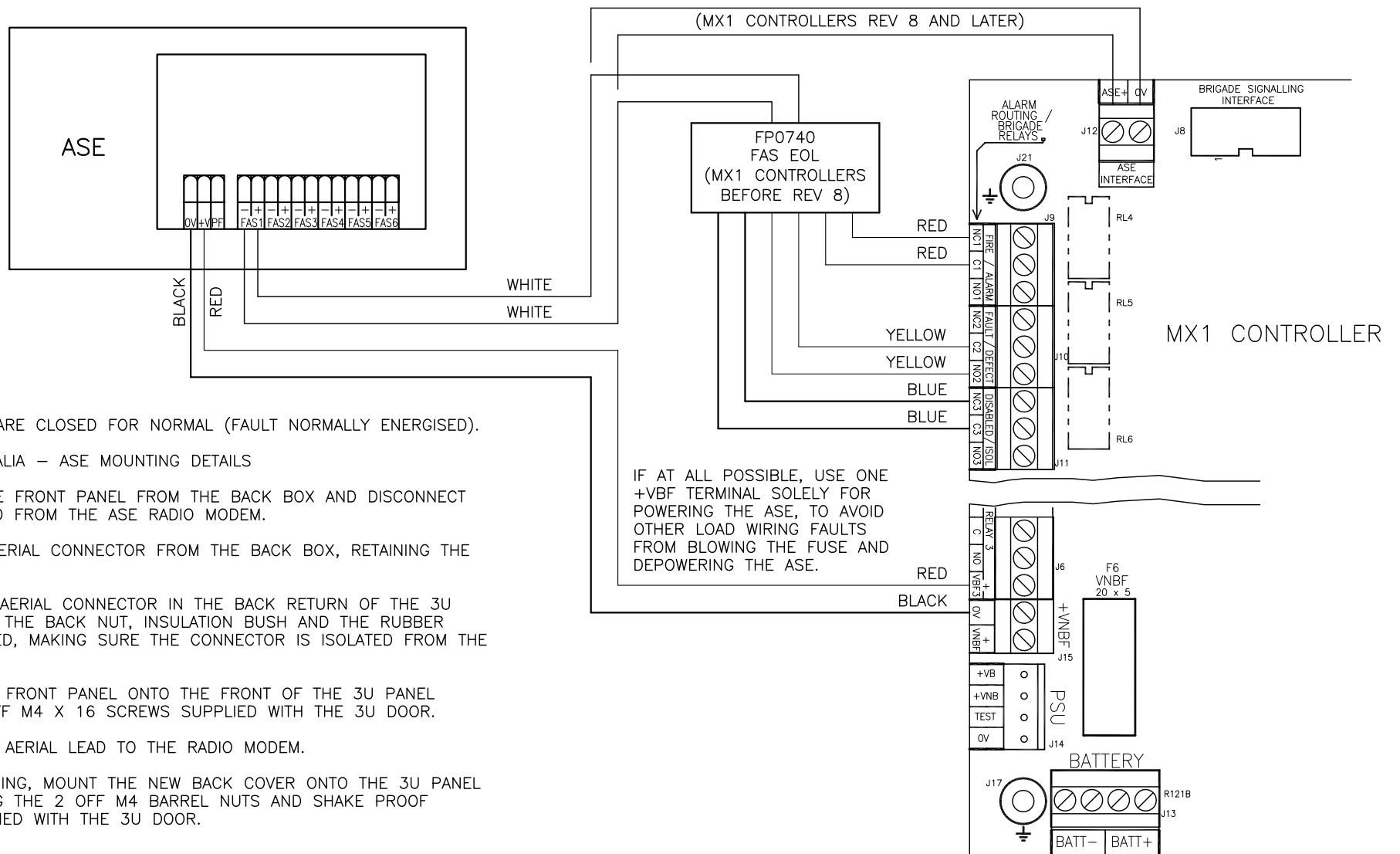

NOTES:

1. MX1 CONTACTS ARE CLOSED FOR NORMAL (FAULT NORMALLY ENERGISED).

FP0927 MX1 AUSTRALIA – ASE MOUNTING DETAILS

1. REMOVE THE ASE FRONT PANEL FROM THE BACK BOX AND DISCONNECT THE AERIAL LEAD FROM THE ASE RADIO MODEM.
2. UNSCREW THE AERIAL CONNECTOR FROM THE BACK BOX, RETAINING THE BACK NUT.
3. RE-MOUNT THE AERIAL CONNECTOR IN THE BACK RETURN OF THE 3U PANEL UTILISING THE BACK NUT, INSULATION BUSH AND THE RUBBER WASHER SUPPLIED, MAKING SURE THE CONNECTOR IS ISOLATED FROM THE PANEL.
4. MOUNT THE ASE FRONT PANEL ONTO THE FRONT OF THE 3U PANEL USING THE 2 OFF M4 X 16 SCREWS SUPPLIED WITH THE 3U DOOR.
5. RECONNECT THE AERIAL LEAD TO THE RADIO MODEM.
6. AFTER FIELD WIRING, MOUNT THE NEW BACK COVER ONTO THE 3U PANEL M4 STUDS USING THE 2 OFF M4 BARREL NUTS AND SHAKE PROOF WASHERS SUPPLIED WITH THE 3U DOOR.

CONFIDENTIAL: THIS DOCUMENT MUST NOT BE COPIED NOR THE CONTENTS PASSED ON TO ANY THIRD PARTY WITHOUT THE CONSENT OF THE COMPANY.

UNLESS OTHERWISE STATED: ALL DIMENSIONS IN MILLIMETRES. DO NOT SCALE. TOLERANCES ARE TO BE: 1 DECIMAL PLACE ±0.5, 2 DECIMAL PLACES ±0.3, 3 DECIMAL PLACES ±0.1

3rd ANGLE PROJECTION

ISS/REV	AMENDMENTS	ECO	DRN	CHKD	AUTH	APVD	DATE
A	ORIGINAL	4011	KJS	GEL	LSC	DP	21-4-09
B	ASE WAS WIRED DIRECTLY TO J12.	ECS1396	KJS	HW	RC	DP	6-11-09
C	J12 OPTION RESTORED, ASE POWER FROM +VBF.	4378	KJS	GEL	LSC	DP	30-5-12

tyco
Fire Protection Products

TYCO FIRE PROTECTION PRODUCTS
17 MARY MULLER DRIVE
P.O. BOX 19545
CHRISTCHURCH, PH: +64 3 3895096
NEW ZEALAND. FAX: +64 3 3895938

MX1
CENTAUR AND CENTAUR II ASE
MOUNTING & FAS WIRING DETAILS

DRAWING No: 1982-71 SHEET 147 of N

A3	ISS/REV	C	PART No:
----	---------	---	----------

NOTES:

- DO NOT CONNECT FIELD WIRING TO SAME +VBF AS NTFST UNIT.

LCD/KEYBRD RELAY	FUNCTION	MIRI INPUT	WIRE COLOUR
1 (NO)	SPRINKLER PUMP RUNNING	9	WHITE
2 (NC)	MCP	11	BLUE
3 (NC)	TAMPER SWT 1 (FIP DOOR)	12	GREEN
4 (NC)	TAMPER SWT 2 (SPRINKLER TAMPER)	13	VIOLET
5 (NC)	FIP AC POWER FAILURE	14	BROWN
COMMON	12 VOLTS	+12V	RED

FRC TO J1
OPEN COLLECTOR OUTPUTS
ON LCD/KEYBRD

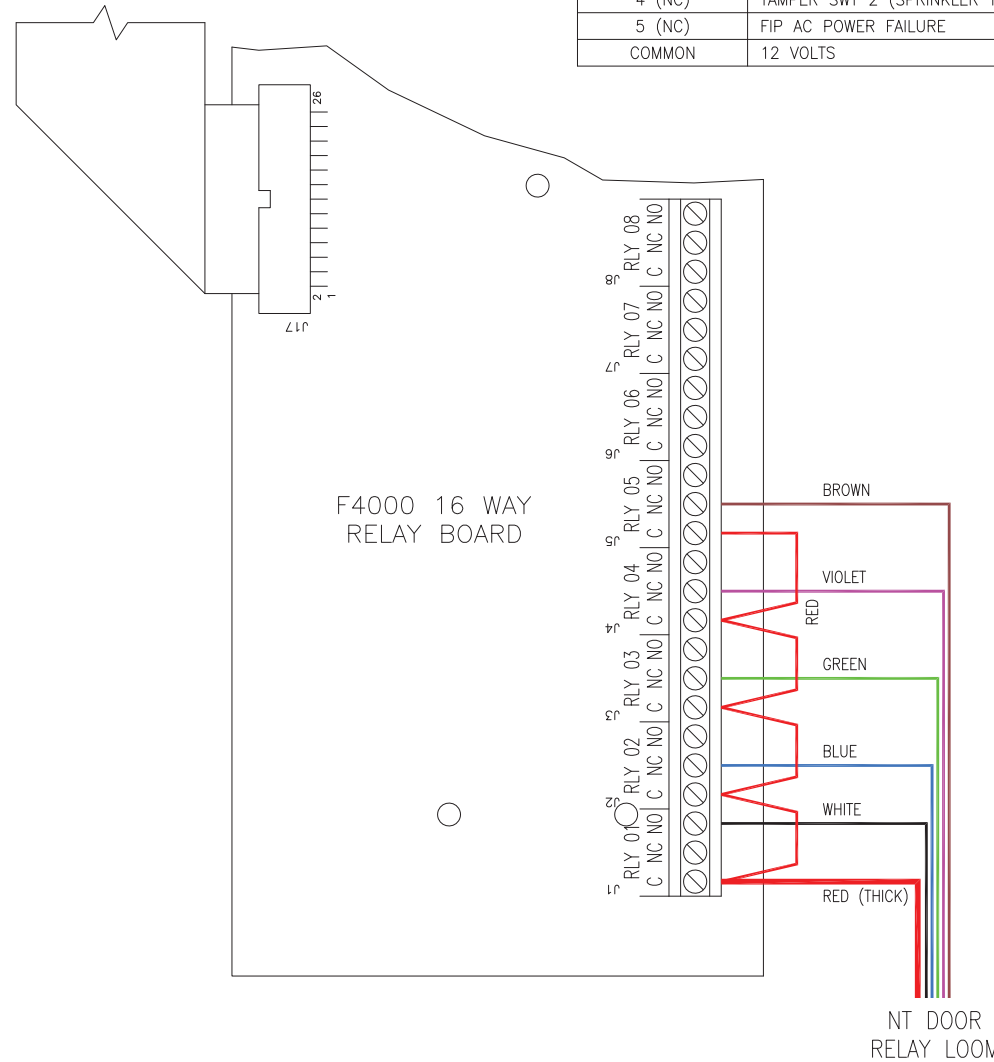
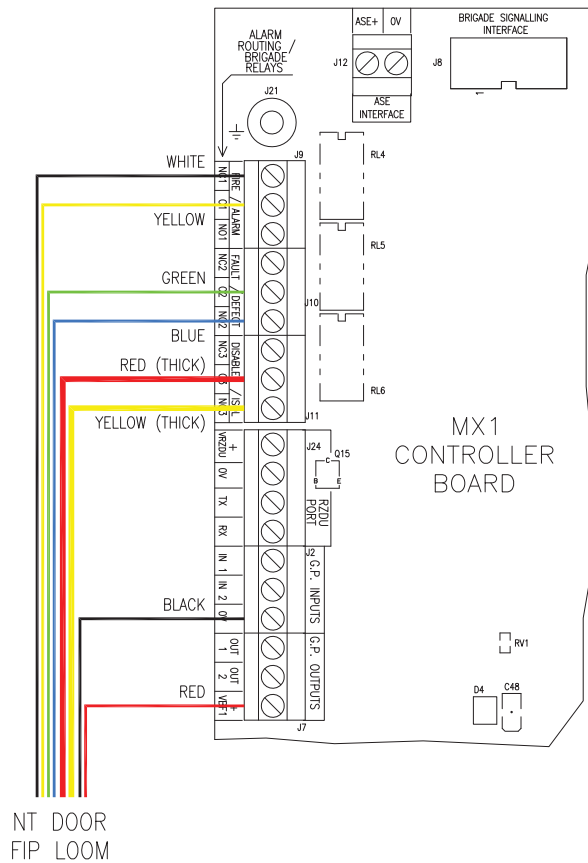

CONFIDENTIAL: THIS DOCUMENT MUST NOT BE COPIED NOR THE CONTENTS PASSED ON TO ANY THIRD PARTY WITHOUT THE CONSENT OF THE COMPANY.

UNLESS OTHERWISE STATED: ALL DIMENSIONS IN MILLIMETRES. DO NOT SCALE. TOLERANCES ARE TO BE: 1 DECIMAL PLACE ±0.5, 2 DECIMAL PLACES ±0.3, 3 DECIMAL PLACES ±0.1

3rd ANGLE PROJECTION

ISS/REV	AMENDMENTS	ECO	DRN	CHKD	AUTH	APVD	DATE
A	ORIGINAL	-	KJS	RC	RC	DP	29-10-15
B	WIRE COLOURS CHANGED AFTER CUSTOMER ASSESSMENT OF FIRST PRODUCTION.	4889	KJS	RC	RC	DP	30-3-16

tyco
Fire Protection Products
TYCO FIRE PROTECTION PRODUCTS
17 MARY MULLER DRIVE
P.O. BOX 19545
CHRISTCHURCH, PH: +64 3 3895096
NEW ZEALAND. FAX: +64 3 3895938

NT BRIGADE DOOR TO MX1 WIRING DETAILS			
DRAWING No: 1982-210 SHEET 2 of 5			
A2	ISS/REV	B	PART No: FP1092

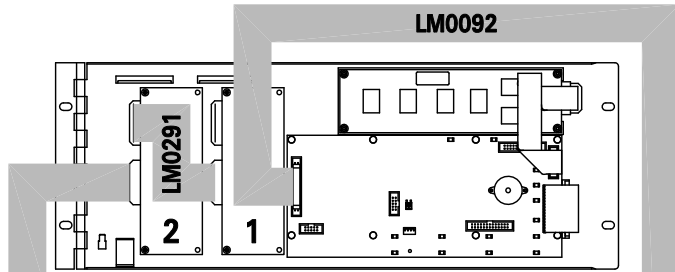

MX1 WITH 2 LED DISPLAY BOARDS FITTED

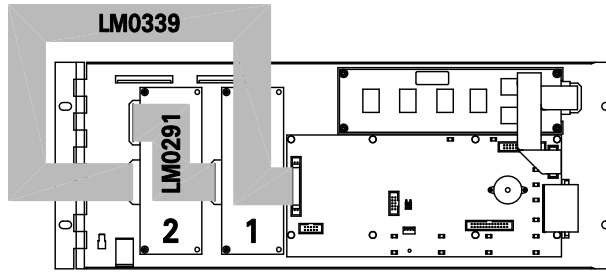

MX1 WITH 1 LED DISPLAY BOARD FITTED

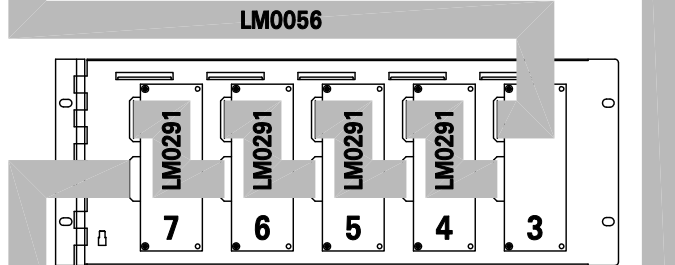
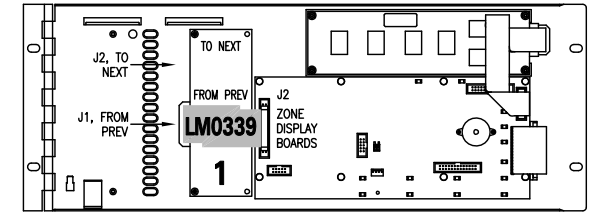

MX1 WITH 12 LED DISPLAY BOARDS FITTED

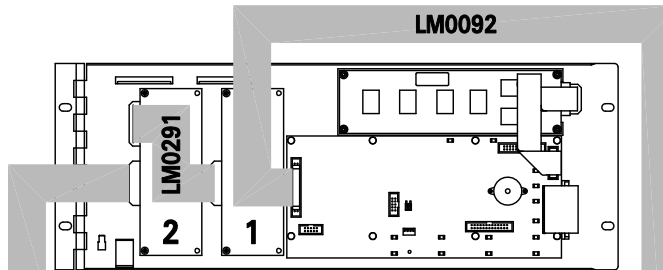

MX1 WITH 5 LED DISPLAY BOARDS FITTED

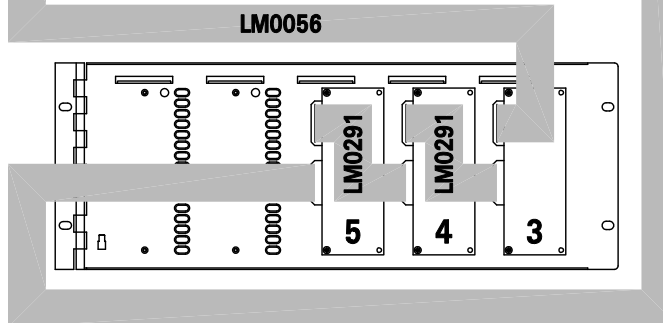

NOTES:

1. DIAGRAMS SHOW CONNECTIONS AND SUGGESTED LOOMS FOR SELECTED QUANTITIES OF MX1 16 ZONE DISPLAY BOARDS.
2. USE THESE DIAGRAMS AS A GUIDE FOR OTHER QUANTITIES OF DISPLAYS/EXTENDERS AND USE OF OTHER COMPATIBLE/EQUIVALENT LOOMS.
3. ALL DISPLAY BOARDS ARE NUMBERED AS SHOWN, WITH ZONE 1 SHOWING ON THE LOWEST NUMBERED BOARD.
4. IF USING ONLY THE KEYBOARD DOOR: LM0339 CONNECTS J2 (ZONE DISPLAY BOARDS) ON THE LCD/KEYBOARD PCB TO J1 (FROM PREVIOUS) ON THE HIGHEST NUMBERED BOARD.
5. USE LM0291 TO CONNECT BETWEEN BOARDS ON THE SAME DOOR. CONNECT J1 (FROM PREVIOUS) FROM A LOWER NUMBERED BOARD TO J2 (TO NEXT) ON THE HIGHER NUMBERED BOARD.
6. IF USING ONE OR TWO ADDITIONAL 80 ZONE EXTENDER DOORS: LM0056 CONNECTS THE BOARDS ON TWO DOORS TOGETHER, J1 (FROM PREVIOUS) FROM A LOWER NUMBERED BOARD TO J2 (TO NEXT) ON THE HIGHER NUMBERED BOARD; LM0092 CONNECTS J2 (ZONE DISPLAY BOARDS) ON THE LCD/KEYBOARD PCB TO J1 (FROM PREVIOUS) ON THE HIGHEST NUMBERED BOARD.

CONFIDENTIAL: THIS DOCUMENT MUST NOT BE COPIED NOR THE CONTENTS PASSED ON TO ANY THIRD PARTY WITHOUT THE CONSENT OF THE COMPANY.

UNLESS OTHERWISE STATED: ALL DIMENSIONS IN MILLIMETRES. DO NOT SCALE. TOLERANCES ARE TO BE: 1 DECIMAL PLACE ±0.5, 2 DECIMAL PLACES ±0.3, 3 DECIMAL PLACES ±0.1

3rd ANGLE PROJECTION

ISS/REV	AMENDMENTS	ECO	DRN	CHKD	AUTH	APVD	DATE
A	ORIGINAL	ECS1376	KJS	MH	LSC	DP	16-9-09
B	NOTES UPDATED. CONNECTOR ID'S ADDED.	ECS1401	KJS	MH	RC	DP	15-1-10
C	NOTES 1 AND 2 UPDATED.	ECS1616	KJS	GEL	LSC	DP	1-2-12
D	DRG BORDER UPDATED TO JCI.	5048	KJS	RC	RC	DC	5-9-17

© 2017 Johnson Controls. All rights reserved. All specifications and other information shown were current as of document revision date and are subject to change without notice.

JOHNSON CONTROLS
 17 MARY MULLER DRIVE
 P.O. BOX 19545
 CHRISTCHURCH, PH: +64 3 3895096
 NEW ZEALAND. FAX: +64 3 3895938

MX1
KEYBRD TO LED DISPLAY BRD
LOOM ROUTING DETAILS

DRAWING No: 1982-88 SHEET 1 of 1

A3	ISS/REV	D	PART No:
----	---------	---	----------

RESISTOR COLOUR CHART

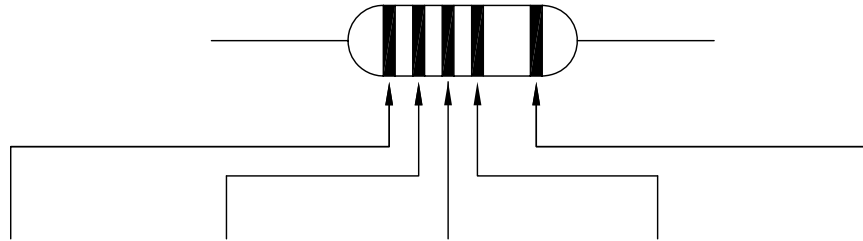

COLOUR	FIRST DIGIT	SECOND DIGIT	THIRD DIGIT (OPTIONAL)	MULTIPLIER	TOLERANCE
BLACK	0	0	0	1	
BROWN	1	1	1	10	1%
RED	2	2	2	100	2%
ORANGE	3	3	3	1,000	
YELLOW	4	4	4	10,000	
GREEN	5	5	5	100,000	
BLUE	6	6	6	1,000,000	
VIOLET	7	7	7		
GREY	8	8	8	0.1 GOLD	5% GOLD
WHITE	9	9	9	0.01 SILVER	10% SILVER

EXAMPLE: RED, VIOLET, BLACK, RED = 27,000 = 27k

COMMON ELDs	BAND 1	BAND 2	BAND 3	BAND 4
2.7k	RED	VIOLET	BLACK	BROWN
9.1k	WHITE	BROWN	BLACK	BROWN
18k	BROWN	GREY	BLACK	RED
27k	RED	VIOLET	BLACK	RED

NOTE: 1% AND 2% TOLERANCES USED.

CONFIDENTIAL: THIS DOCUMENT MUST NOT BE COPIED NOR THE CONTENTS PASSED ON TO ANY THIRD PARTY WITHOUT THE CONSENT OF THE COMPANY.

UNLESS OTHERWISE STATED: ALL DIMENSIONS IN MILLIMETRES. DO NOT SCALE. TOLERANCES ARE TO BE: 1 DECIMAL PLACE ±0.5, 2 DECIMAL PLACES ±0.3, 3 DECIMAL PLACES ±0.1

3rd ANGLE PROJECTION

ISS/REV	AMENDMENTS	ECO	DRN	CHKD	AUTH	APVD	DATE
A	ORIGINAL	-	KJS	RC	RC	DP	26-2-09

tyco / Safety Products

TYCO SAFETY PRODUCTS
17 MARY MULLER DRIVE
P.O. BOX 19545
CHRISTCHURCH, PH: +64 3 3895096
NEW ZEALAND. FAX: +64 3 3895938

RESISTOR COLOUR CODE INFORMATION		
DRAWING No:	1922-98	SHEET 1 of 1
A3	ISS/REV A	PART No:

 **VIGILANT**