

Compatible Detectors

The AZM800 is compatible with the types and quantities of detectors listed in Table 1. Detector numbers depend on AZM800 detector configuration.

The total standby current of all detectors connected to an AZM800 must not exceed 700µA for the Normal detector circuit setting or 150µA for the Low Current detector circuit setting.

Table 1 – Conventional detector devices compatible with AZM800					
Brand	Detector Type	Alarm Type	Standby current (µA)	Max. Number (Normal setting)	Max. Number (Low Current setting)
System Sensor	2351E	Smoke/Heat *	65	10	2
	2351TEM	Smoke/Heat *	80	8	1
	4351E	Heat *	90	8	1
	5351E	Heat *	80	8	1
	1151	Smoke	40	16	3
	2151	Smoke	45	16	3
Tyco	614CH	CO/Heat *	70	10	2
	614P	Smoke	60	11	2
	614T	Heat *	85	8	1
Vigilant	VNCPI, VNCPI-W Indicating MCP	Heat/MCP	18	35	8
	Indi-VIGIL Mk2 Heat Detector	Heat/MCP	18	35	8
	1841 Indicating Manual Call Point	Heat/MCP	18	35	8
	PA1022 Clean Contact Adaptor	Heat/MCP	18	35	8

* These heat detectors will not produce a brigade alarm unless the AZM800 is specially configured, in which case, any smoke or heat alarm on that AZM800 will produce a latching brigade alarm.

Mounting Requirements

The AZM800 mounts on a standard single electrical flush box. Since each AZM800 will have at least 5 and up to 8 cables connected to it, the flush box must have enough room for these cables or have an open back.

Some suitable flush box parts are: PDL cat 145V, Superlux FB-0.



There are some types of mounting plate with metal clips that clip onto the wallboard. The metal clip on the front side of the wallboard may make contact with the circuit board of the AZM800 when it is fitted, causing faults and other incorrect operation. These types of mounting are not recommended.



Penetrations in fire-rated walls may require fire stopping, e.g., fire rated flush boxes with intumescent pads.

Converting to Blank Cover

If the internal silence/hush button in the AZM800 is not required, it can be disabled as follows:

- Remove the single hole coverplate,
- Peel off the labelled button overlay,
- Remove the push button actuator,
- Fit the blank coverplate supplied.

Wiring

The AZM800 uses four demountable connectors for field wiring. These connectors must be terminated to the building cables, then plugged into the AZM800. Four coloured cable ties (supplied with each AZM800) should be used to tag the cables wired to each connector, to match the colours printed on the AZM800 circuit board (see Figure 4b). This is very important for technician safety (100V line) and for ease of future servicing.

General wiring of field devices (detectors and loudspeakers) is shown in Figure 2.

Wiring details for these four connectors are shown in Figure 3.

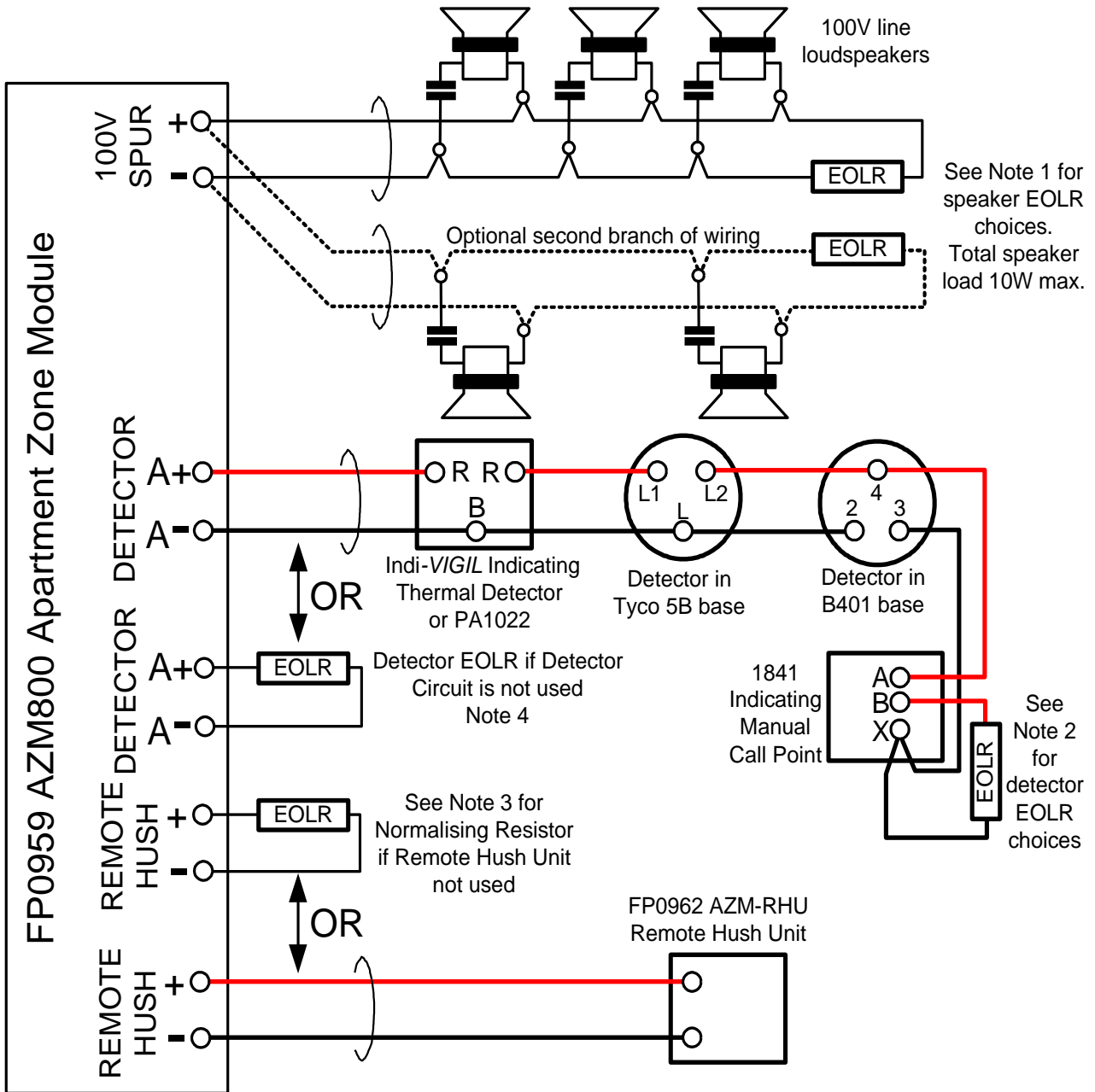
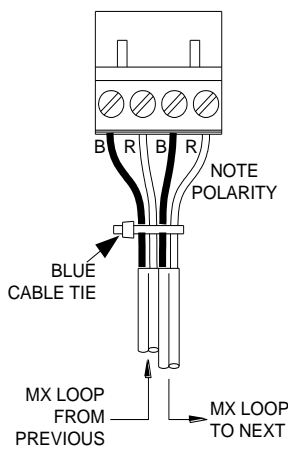

Figure 2 – Wiring of Local Detector and 100V Speaker Circuits

Notes

1. A single branch of speaker wiring uses 56kΩ EOLR (marked green-blue-black-red). A dual branch of speaker wiring uses 100kΩ EOLR (not supplied) on each branch.
2. Normal detector circuit uses a 9.1kΩ EOLR (marked white-brown-black-brown). Low Current detector circuit uses a 18kΩ EOLR (marked brown-grey-black-red). Detectors and manual call points can be connected in any order on the detector circuit.
3. When a Remote Hush Unit is not used, fit a 9.1kΩ Normalising Resistor (marked white-brown-black-brown).
4. Unused detector circuits should preferably be configured as Low Current. The default (Normal) detector circuit setting uses more current from the *MX* Loop.



A shows the wiring for the MX addressable loop cables.

Tag colour is **BLUE**.

A – MX Addressable Loop

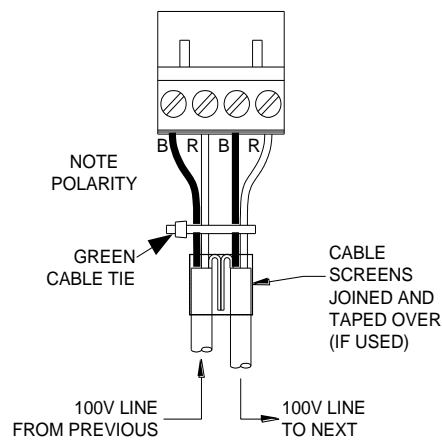

B shows the wiring for the 100V feeder loop cables.

Tag colour is **GREEN**.

B – 100V Feeder Loop

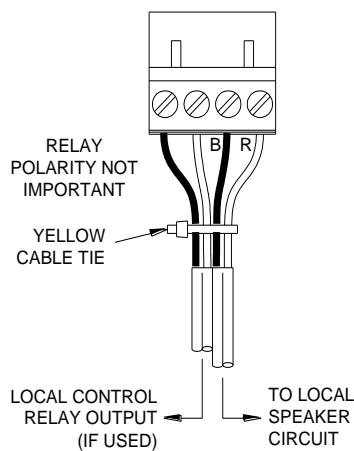

C1 – Speakers and Relay

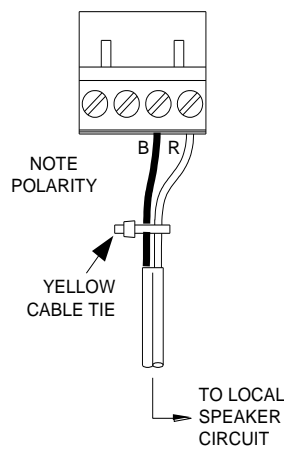

C2 – Speakers only

C1 shows the wiring for the local 100V speaker circuit and the local control relay output.

C2 shows the wiring when the local control relay is not used.

Tag colour is **YELLOW**

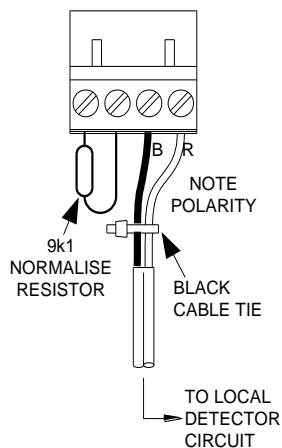

D1 – Detectors only, no RHU

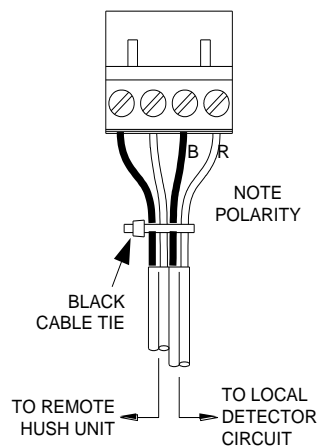

D2 – Detectors and RHU

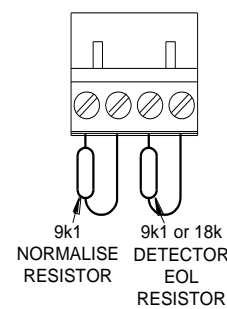

D3 – No detectors, no RHU

D1 through D3 show wiring options for the local detector circuit and Remote Hush Unit.

Tag colour is **BLACK**

Figure 3 – Wiring field cables to AZM800 Terminal Blocks

Fitting the AZM800

When all the terminal blocks are wired and tagged, these should be arranged as shown in Figure 4a, to match the connector positions on the AZM800.

Plug each terminal block into the corresponding connector of the AZM800. These are each labelled with the colour of the tag, as shown in Figure 4b.

When all terminals are correctly fitted, the AZM800 can be mated to the flush box and fastened in place with the mounting screws supplied.



Do not overtighten the mounting screws, since this may affect the operation of the internal hush button. After tightening the screws check the action of the hush button – there should be a noticeable click when it is pressed firmly. If the button does not click and it seems to be bulging, loosen the mounting screws until the action frees up.

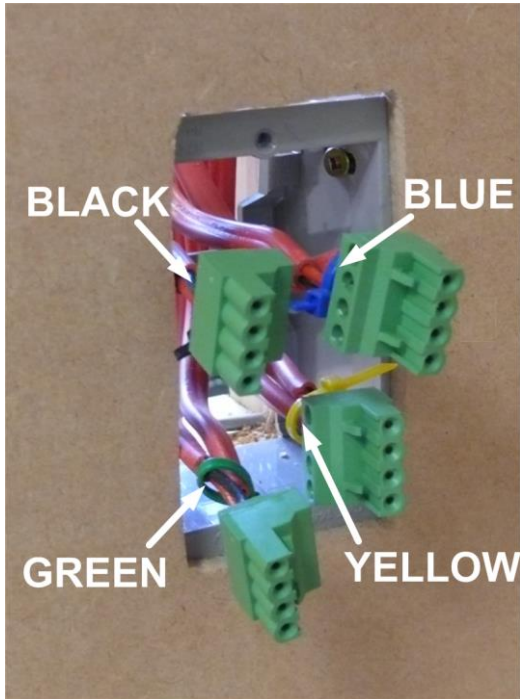

Figure 4a – Terminated Connectors ready for AZM800 to be fitted



Figure 4b – Colour Code Labels on AZM800

Configuration

The following options can be configured at each AZM800:

1. Device Address – default 255 (=unallocated).
2. Hush Period: 2, 3, 4 or 5 minutes – default is 2 minutes.
3. Normal/Low Current detector circuit – default is Normal.
4. Non-latching or Latching smoke detector operation – default is Non-latching.
5. Ancillary relay output normally-open or normally-closed – default is normally-open.

Configuration of an AZM800 requires an 850EMT *MX* Engineering Management Tool, 801AP *MX* Service Tool, or other approved *MX* addressable module programming device.

The probe lead of the 850EMT or 801AP programming tool can be plugged into the AZM800 once the cover plate is removed (see Figure 5). It does not require removal from the wall.

It does not matter whether the AZM800 is connected to the *MX* loop or not. The programming tool will override the commands from the fire panel.

Note that the 801AP Service Tool will identify the AZM800 as an MIO800. The 850EMT Engineering Management Tool will correctly identify the AZM800.



Figure 5 – Connecting the Programming Tool

Setting the AZM800 Device Address

This is the same as for other *MX* addressable devices. For the 801AP, from the Main Menu of the Service Tool, select **ADDRESS, WRITE**, set the address, **WRITE**. For the 850EMT, select **DEVICE STATUS**, then **Change Address**, set the address, **ENTER**.

Setting other AZM800 Options

For the 801AP, from the main menu of the Service Tool, select **DIGITAL OUTPUTS**. For the 850EMT, from the home screen select **TEST FUNCTIONS**, followed by **TEST DIGITAL OUTPUT**. Set the programming tool to **00000000** and write this to the AZM800.

For each setting to be adjusted:

1. Set the programming tool to **00000001** (older 801AP Service Tool version 2.0) or **10000000_L** (850EMT all versions, or 801AP with software version 2.2 or later) and write this to the AZM800. The internal yellow Status LED should glimmer faintly. The next step must be completed within 90 seconds to be accepted by the AZM800.
2. Choose the appropriate value from Table 2 which matches the setting to be changed. Set the programming tool to this number and write this to the AZM800. The yellow Status LED will turn on steady for five seconds if this setting is accepted. If not, go back to the previous step and start again.
3. Set the programming tool to **00000000** and write this to the AZM800 to finish the sequence.

When all settings are correct, unplug the Service Tool from the AZM800.

Table 2 – Setting Values to write to the AZM800 with the programming tool

Setting	Options	Older 801AP Service Tool (v2.0)	850EMT (all) or Newer 801AP Service Tool (v2.2 or later)
Hush Period for Smoke Alarms	2 minutes (default)	00101000	00010100 _L
	3 minutes	01101000	00010110 _L
	4 minutes	00011000	00011000 _L
	5 minutes	01011000	00011010 _L
Maximum Detector Standby Current	Normal Current 0.7mA (default)	00000100	00100000 _L
	Low Current 0.15mA	01000100	00100010 _L
Smoke Alarm Behaviour	Non-Latching, hushable (default)	00001100	00110000 _L
	Latching, not hushable	01001100	00110010 _L
Local Control Relay Output	Normally Open (default)	00000010	01000000 _L
	Normally Closed	01000010	01000010 _L

Commissioning

There is no special adjustment required for commissioning.

MX Loop wiring faults can be traced by using the fire panel or *MX* Loop Tester to report which AZM800 addresses are missing. All these faults must be cleared first.



Do not test the tone generator and the sounder wiring until the *MX* Loop wiring is confirmed as correct. If the 100V feeder loop is accidentally connected to the *MX* Loop terminals of any AZM800, that module may be damaged if the tone generator is operated.

Fault Status Indicator

Each AZM800 will display any local off-normal conditions on its yellow Status LED when either the internal or remote Hush button is pressed. If there are any conditions to display the Status LED will flash 8 times. A long flash indicates that the corresponding condition is present.

1 st	Detector Circuit Open or Leaky
2 nd	Detector Circuit Short
3 rd	Speaker Circuit Open
4 th	Speaker Circuit Short
5 th	Remote Hush Circuit Open
6 th	Remote Hush Circuit Short
7 th	AZM800 Internal Defect
8 th	Heat Detector/MCP Activated

Each AZM800 will report local wiring faults to the fire panel encoded in its local detector circuit analogue point value as shown below:

0-29	Internal AZM800 fault
30-49	Remote Hush Shorted
50-69	Remote Hush Open
70-89	Local Speaker Shorted
90-109	Local Speaker Open
110-129	Detector Circuit Shorted
130-149	Detector Circuit Open or Leaky
150-175	Normal, self test passed
175-199	Normal
200-255	Alarm

Operation and Alarm Status Indicator

The red Alarm indicator is normally off. The fire panel may flash this indicator on poll, if it is configured to do so (not recommended, except for commissioning).

When a local (non-latching) smoke alarm is present, the Alarm indicator will flash rapidly, and the AZM800 will switch an Alert tone from the fire panel to the local loudspeakers. If the Silence button on the AZM800 or Remote Hush Unit is pressed, the Alarm indicator will flash slowly and the Alert tone in the loudspeakers will be silenced. If the hush period ends before the smoke is cleared, the fast flash and the Alert tone will resume. When the smoke is cleared, the flashing and the Alert tone will stop.

If a heat detector or MCP connected to the AZM800 is activated, the AZM800 will signal this to the fire panel, but it will not light its Alarm indicator unless commanded by the fire panel. The indicator on the activated heat detector or MCP will light as usual.

When a brigade alarm is present, the fire panel commands all AZM800s to switch Evacuation tone from the fire panel to all local loudspeakers. None of the AZM800s will light their Alarm indicators.

AZM800 Specifications

System Compatibility:	Vigilant <i>MX1</i> (firmware V1.20, or later), or Vigilant <i>MX4428</i> ((firmware V3.21, or later) with <i>MXP</i> (firmware V1.15, or later).
Environment:	Indoor Application only.
Operating Temperature:	-10° to +45°C.
Storage Temperature:	-40° to +80°C.
Operating Humidity:	10% to 95% RH (non-condensing).
Format:	PDL 600 series module.
Dimensions (HWD):	118 x 75 x 34 mm.
Mounting Requirements:	Standard Aus/NZ single electrical flush box.
<i>MX</i> Loop Voltage:	22 to 40VDC.
Current from <i>MX</i> Loop:	4mA normal, 17mA alarm if local detector operated, 5mA alarm otherwise.
Detector Circuit Voltage:	12 to 14VDC depending on <i>MX</i> addressable Loop voltage.
Max. Detector Current:	0.7mA (normal setting, default), 0.15mA (low current setting) quiescent, 15mA (12mA nominal) in alarm.
Detector Circuit EOLR:	9k1Ω (normal setting), 18kΩ (low current setting).
Detector Circuit Resistance:	10Ω maximum.
Local 100V Loudspeaker Circuit:	10W load maximum @ 100V line. 56kΩ EOLR (presents 0.2W extra load). Supervised o/c or s/c = Fault.
Hush Period:	Selectable 2 (default), 3, 4, or 5 minutes.
Local Control Relay Output:	Can be set for Normally Open (default) or Normally Closed, 30VDC 1A resistive, 0.5A inductive.

Ordering Codes

- FP0959 AZM800 Apartment Zone Module, including connectors, mounting screws, EOLRs for detector and speaker circuits, cable ID tags, spare blank cover plate, installation instructions.
- FP0962 AZM800-RHU Remote Hush Unit.

FP0959 Contents

- 1 x AZM800 module with cover plate, white
- 2 x fastening screws for the flush box
- 1 x blank switchplate cover, white
- 4 x coloured cable ties: black, blue, green, yellow
- 4 x 4-way terminal blocks
- 2 x 9k1 EOLRs – detector circuit and/or remote hush circuit – marked white-brown-black-brown
- 1 x 18k EOLR – low current detector circuit - marked brown-grey-black-red
- 1 x 56k EOLR – local loudspeaker circuit - marked green-blue-black-red
- 1 x these Installation Instructions (LT0459)

FP0962 Contents

- 1 x AZM-RHU module with cover plate, white
- 2 x fastening screws for the flush box

Manufactured By:
Johnson Controls
17 Mary Muller Drive
Christchurch 8022, New Zealand
Tel: +64-3-389 5096

Distributed By:



© 2019. Johnson Controls. All rights reserved. All specifications and other information shown were current as of document revision date and are subject to change without notice.