

## Introduction

Existing 4100+ or 4100A system hardware can be upgraded to 4100U by fitting the appropriate upgrade kit.

## Upgrade Kits – to convert to a 4100U system

Kit	What It Contains and What It Is Used For
<b>4100-KT0488</b> 4100 CABINET UPGRADE TO 4100U AS4428	4100U LCD User Interface on a swing-down bay door assembly and a 4100U CPU card. These are fitted in place of the existing 4100A or 4100+ door and CPU card. The rest of the system hardware does not require change.
<b>4100-7149K</b> 4100 TO 4100U UPGRADE KIT FOR 19" CABINET	4100U 4U LCD User Interface door assembly and a 4100U CPU card. These are fitted in place of the existing 4U 4100A or 4100+ door and CPU card in a 19" rack cabinet, reusing the 4100-0157A PSU. The rest of the system hardware does not require change.
<b>4100-7152K</b> 4100 CLASSIC TO 4100U UPGRADE KIT	Complete replacement CPU bay, including power supply, 8 relay card, 6 signal card, and 4100U CPU card. This completely replaces the existing CPU bay in a classic 4100 system, since that power supply is not suitable for the 4100U. Note that the power supply in this kit is the older 4100-0157A type, not a 4100U SPS.

## Replacement Kits – for systems that have already been upgraded

Kit	What It Contains and What It Is Used For
<b>4100-KT0486</b> 4100U AUST LCD 4U DOOR REPLACEMENT	4100U 4U LCD User Interface door assembly for a 4100U system in a 19" cabinet, to replace a scratched or otherwise damaged door.
<b>4100-KT0470</b> 4100U LEGACY DOOR AS4428 REPLACEMENT	Replacement 4100U LCD User Interface on a swing-down Legacy bay door, to replace a scratched or otherwise damaged door in an <u>upgraded</u> system. This door does <u>not</u> fit onto the newer 4100U Bay.

Except where noted above, all other existing cards in the 4100 system being upgraded can be reused after the upgrade.

There is also new scope for expansion, e.g., by adding an ID-Net card, or replacing existing MAPNET cards and motherboards with ID-Net cards.

However, note that some MAPNET devices cannot be used with ID-Net, which might limit this option in some installations.

## Cautions and Warnings

**READ AND SAVE THESE INSTRUCTIONS.** Follow the instructions in this installation manual.

These instructions must be followed to avoid damage to this product and associated equipment. Product operation and reliability depends upon proper installation.

**DO NOT INSTALL ANY SIMPLEX PRODUCT THAT APPEARS DAMAGED.**

Upon unpacking your Simplex product, inspect the contents of the carton for shipping damage. If damage is apparent, immediately file a claim with the carrier and notify an authorized Simplex product supplier.

**ELECTRICAL HAZARD** - Disconnect electrical field power when making any internal adjustments or repairs. Servicing should be performed by qualified Simplex representatives.

**STATIC HAZARD** - Static electricity can damage components. Therefore, handle as follows:

- Ground yourself before opening or installing components.
- Prior to installation, keep components wrapped in anti-static material at all times.

**RADIO FREQUENCY INTERFERENCE** - This equipment has been tested and found to comply with the limits for a Class A digital device, pursuant AS/NZS CISPR 22. These limits are designed to provide reasonable protection against harmful interference when the equipment is operated in a commercial environment. Operation of this equipment in a residential area is likely to cause harmful interference in which case the user will be required to correct the interference at his own expense.

**SYSTEM SOFTWARE CHANGES** - All these 4100U upgrade options involve replacing the 4100 CPU card with a 4100U card.

The old 4100 site-specific software file will **NOT** work with the new 4100U card. The old 4100 site-specific software must be converted into a version compatible with the 4100U system and loaded into the new system before normal operation will be restored.

Converting the site-specific software is beyond the scope of these Installation Instructions. Contact your Simplex service agent for assistance with this conversion.

**SYSTEM REACCEPTANCE TEST AFTER SOFTWARE CHANGES** - To ensure proper system operation after the upgrade, this product must be tested in accordance with AS 1670.1 after any programming operation or change in site-specific software. Reacceptance testing is required after any change, addition or deletion of system components, or after any modification, repair or adjustment to system hardware or wiring.

All components, circuits, system operations, or software functions known to be affected by a change must be 100% tested. In addition, to ensure that other operations are not inadvertently affected, at least 10% of initiating devices that are not directly affected by the change, up to a maximum of 50 devices, must also be tested and proper system operation verified.

## About the Upgrade Kits

---

### 4100-KT0488 LCD Door for Legacy cabinets

Upgrade a 4100 Legacy Cabinet To 4100U

#### Kit Contents:

- 4100U LCD Door to fit 4100+ or 4100A Legacy style cabinet, with Australian keypad and overlay, keypad PCB, sounder, CPU Harness and Download Harness,
- 4100U CPU card

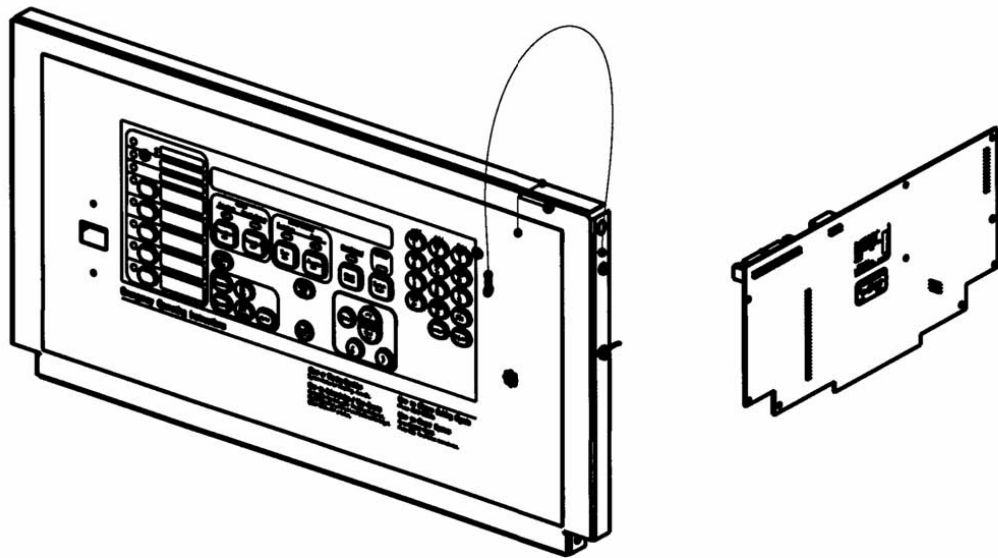

Figure 1 – 4100-KT0488 Legacy Bay Door and 4100U CPU Card

#### Replacement Procedure:

- Power the system down: remove AC power from the PSU and remove the red lead from the positive battery terminal.
- Unplug the two FRCs of the door to be replaced from the 4100 CPU board.
- Disconnect the earth looms from the faulty door.
- Remove the obsolete (4100) door.
  - Disconnect the operator interface support wire from the bay.
  - Locate two pins on the top two corners of the interface that prevent it from opening. Push these pins outward and swing the door down.
  - Remove the clips from the pins that hold the lower two corners of the door to the bay and then push these pins outward. Retain all removed items. Now you can remove the door.Keep the the door fasteners and washers for use with the new door.
- Configure the links on the upgrade (4100U) CPU card as follows:
  - **P1** is used for engineering diagnostics (COMLAB). Normally has no link fitted.
    - Position 1 – 2 : Download or no connection.
    - Position 2 – 3 : Diagnostic mode.
  - **P3** configures the RAM battery as ON or OFF.
    - Position 1 – 2 : ON – move to this position for normal operation.
    - Position 2 – 3 : OFF – factory setting.
- Remove the obsolete (4100) CPU card. Fit the configured upgrade (4100U) CPU card in its place.

- Fit the upgrade (4100U) door, using the fastening hardware from the obsolete door. Connect the support wire, earth looms and FRCs from the new door to the new CPU card.
- Apply the mains to the power supply, and check that the cards power up correctly. When this is confirmed, reconnect the battery.  
Note that the system will not operate correctly until the new site specific software is loaded into the new CPU card.

**4100-7149K  
Upgrade Kit for  
19" Cabinet**

**Kit Contents:**

- 4100U 4U LCD User Interface door assembly
- 4100U CPU card

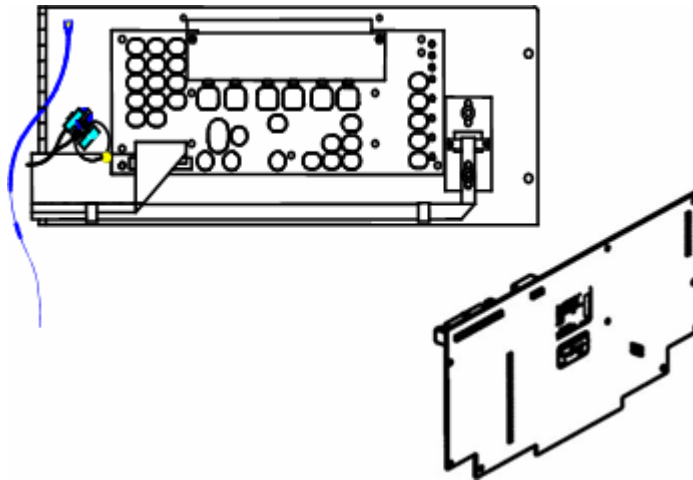

Figure 2 – 4100-7149K 4U LCD Door and 4100U CPU Card

**Replacement Procedure:**

- Power the system down: remove AC power from the PSU and remove the red lead from the positive battery terminal.
- Unplug the two FRCs of the old 4U 4100 door from the 4100 CPU board.
- Disconnect the earth looms from the old 4U door.
- Remove the old 4U door after removing the four M6 mounting screws. Keep these screws and washers for use with the new door.
- Configure the links on the upgrade (4100U) CPU card as follows:
  - **P1** is used for engineering diagnostics (COMLAB). Normally has no link fitted.
    - Position 1 – 2 : Download or no connection.
    - Position 2 – 3 : Diagnostic mode.
  - **P3** configures the RAM battery as ON or OFF.
    - Position 1 – 2 : ON – move to this position for normal operation.
    - Position 2 – 3 : OFF – factory setting.
- Remove the obsolete (4100) CPU card. Fit the upgrade (4100U) CPU card in its place.
- Fit the new 4U door in place of the old door, using the fastening hardware from the old door. Connect the earth looms and FRCs from the new door to the new CPU card.
- Apply the mains to the power supply, and check that the cards power up correctly. When this is confirmed, reconnect the battery.  
Note that the system will not operate correctly until the new site specific software is loaded into the new CPU card.

---

**4100-7152K  
Master Controller  
Upgrade Kit**

**Kit Contents:**

- Complete 4100U CPU bay, containing:
  - LCD door assembly with Australian keypad and overlay
  - 4100U CPU card
  - 4100-3003 8 Relay Card,
  - 4100-4321 6 Signal Card,
  - 4100-0157A power supply,
  - 002-109 DC Fuse Card

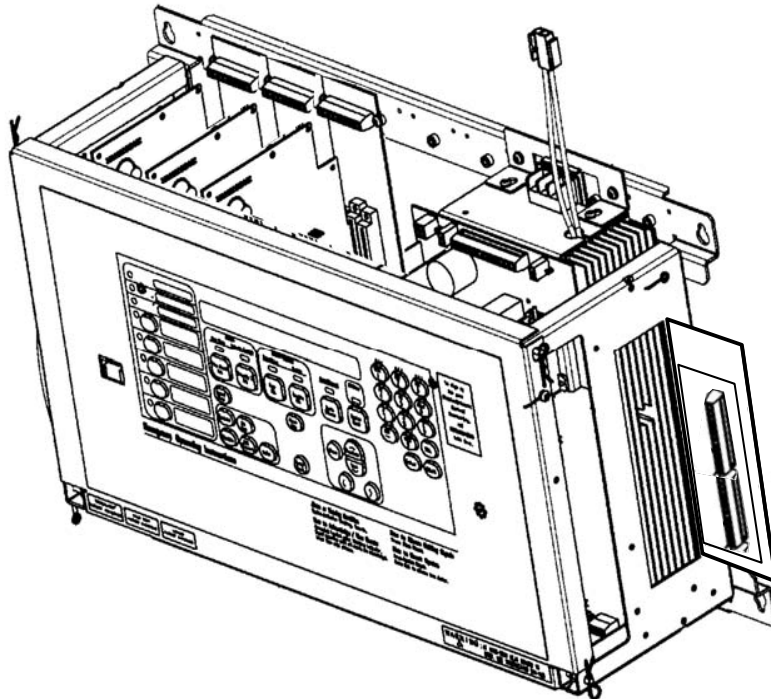

Figure 3 – External view of the 4100-7152K Upgrade Bay

**Replacement Procedure:**

- Power the system down: remove AC power from the PSU and remove the red lead from the positive battery terminal.
- Arrange for a suitably qualified electrician to disconnect the mains power from the CPU bay being replaced.
- Remove connections from the CPU bay being replaced to other bays, the door switch and the batteries.
- Remove this CPU bay.
- Configure the links on the upgrade (4100U) CPU card as follows:
  - **P1** is used for engineering diagnostics (COMLAB). Normally has no link fitted.
    - Position 1 – 2 : Download or no connection.
    - Position 2 – 3 : Diagnostic mode.
  - **P3** configures the RAM battery as ON or OFF.
    - Position 1 – 2 : ON – move to this position for normal operation.
    - Position 2 – 3 : OFF – factory setting.
- Fit the upgrade CPU bay, and restore connections from the other bays, doorswitch and batteries. Do NOT power the system from the batteries at this stage.
- **Caution:** Make certain that no wires are pinched or damaged during the installation of the new bay.

- Arrange for the electrician to connect the mains power to the switched outlet in the new CPU bay.
- Apply the mains to the power supply, and check that the cards power up correctly. When this is confirmed, reconnect the battery.  
Note that the system will not operate correctly until the new site specific software is loaded into the new CPU card.

**4100-KT0470  
LCD Door for  
Legacy Bays**

4100U Legacy Door AS4428 Replacement

**Kit Contents:**

- 4100U LCD User Interface door assembly to fit 4100+ or 4100A Legacy style cabinet, with AS4428 keypad and overlay, keypad PCB, sounder, CPU Harness and Download Harness.
- No mounting parts

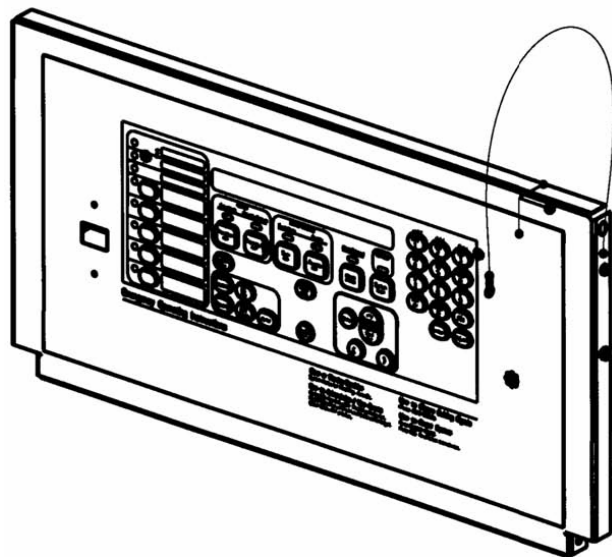

Figure 4 – Replacement Legacy Bay Door

**Replacement Procedure:**

- Power the system down: remove AC power from the PSU and remove the red lead from the positive battery terminal.
- Unplug the two FRCs of the damaged door to be replaced from the Master Controller board.
- Disconnect the earth looms from the faulty door.
- Remove the damaged door.
  - Disconnect the operator interface support wire from the bay.
  - Locate two pins on the top two corners of the interface that prevent it from opening. Push these pins outward and swing the door down.
  - Remove the clips from the pins that hold the lower two corners of the door to the bay and then push these pins outward. Retain all removed items. Now you can remove the door.
 Keep the the door fasteners and washers for use with the new door.
- Fit the replacement door, using the fastening hardware from the old door. Connect the support wire, earth looms and FRCs from the new door.
- Apply the mains to the power supply, and check that the system powers up correctly. When this is confirmed, reconnect the battery.

**4100-KT0486  
4U LCD Door for  
19" cabinets**

4100U 4U LCD door for a 4100U system in a 19" cabinet, to replace a scratched or otherwise damaged door.

**Kit Contents:**

- 4U LCD User Interface door assembly with Australian keypad and overlay, keypad PCB, sounder, CPU Harness and Download Harness
- Mounting parts.

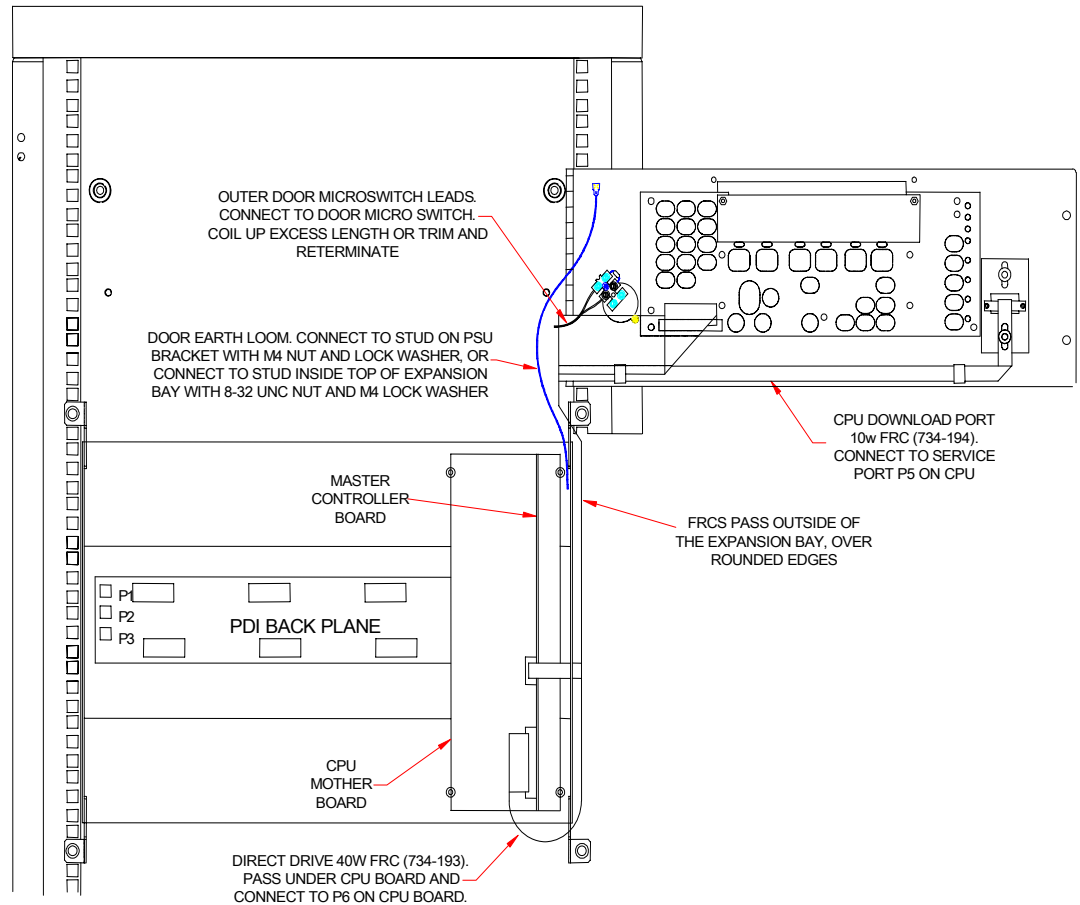

Figure 5 – Fitting replacement 4U LCD door to 4100U cabinet

**Replacement Procedure:**

- Power the system down: remove AC power from the PSU and remove the red lead from the positive battery terminal.
- Unplug the two FRCs of the faulty door to be replaced from the Master Controller board.
- Disconnect the earth looms from the faulty door.
- Remove the faulty door. Keep the door mounting screws and washers for use with the new door.
- Fit the replacement door. Connect the earth looms and FRCs as described in Figure 5.
- Apply the mains to the power supply, and check that the system powers up correctly. When this is confirmed, reconnect the battery.

