

ALL CABINETS ARE MADE OF 1.6mm ZINC COATED STEEL.

WELDED CONSTRUCTION.

CABINETS ARE FINISHED IN CREAM WRINKLE POWDERCOAT. (BFF 998 CW, OXYPLAST)

THE WINDOW IN ALL CABINETS IS 3.0mm CLEAR ACRYLIC.

CABINETS ARE SYMMETRICAL, SO TO CONVERT TO RH HINGING, TURN CABINET 'UPSIDE DOWN'.

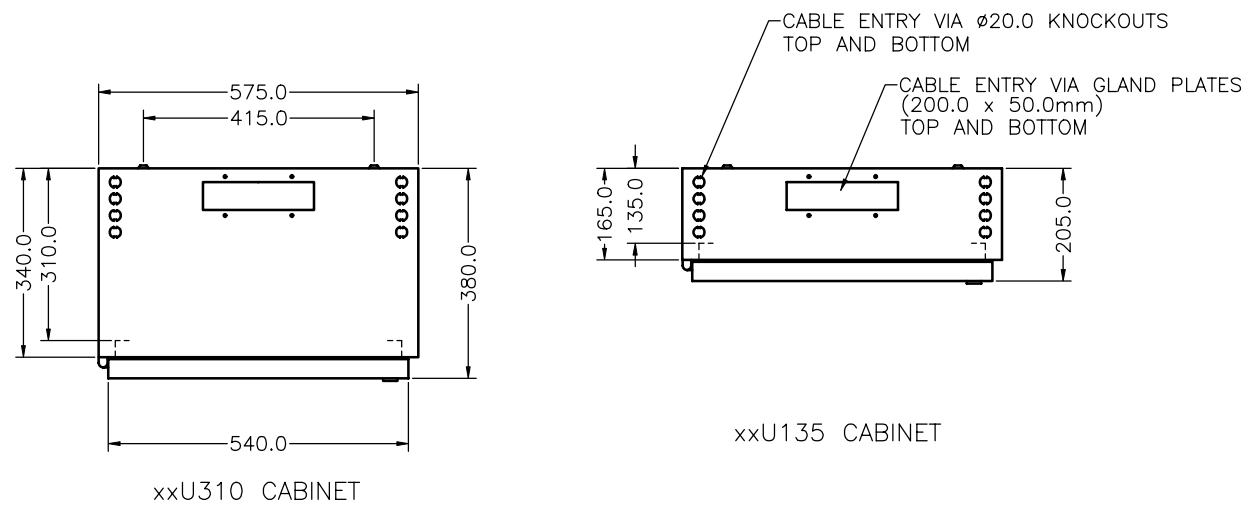

10mmsq HOLES TO TAKE M6 CAGE NUT

003 KEY LOCK

DIMPLED MOUNTING HOLES (Ø6.50)

M6 x 20 STUDS FOR GEAR PLATE MTG

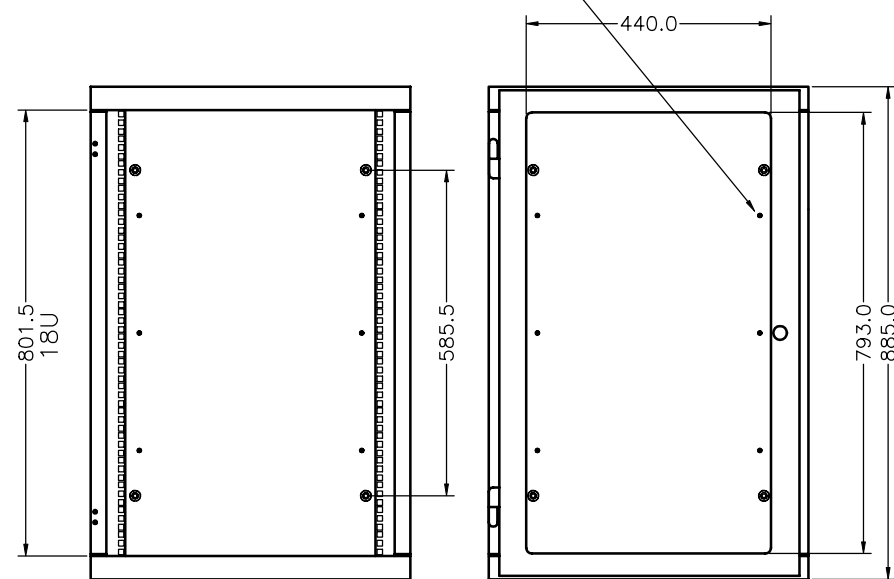

INSIDE VIEW
18U CABINET

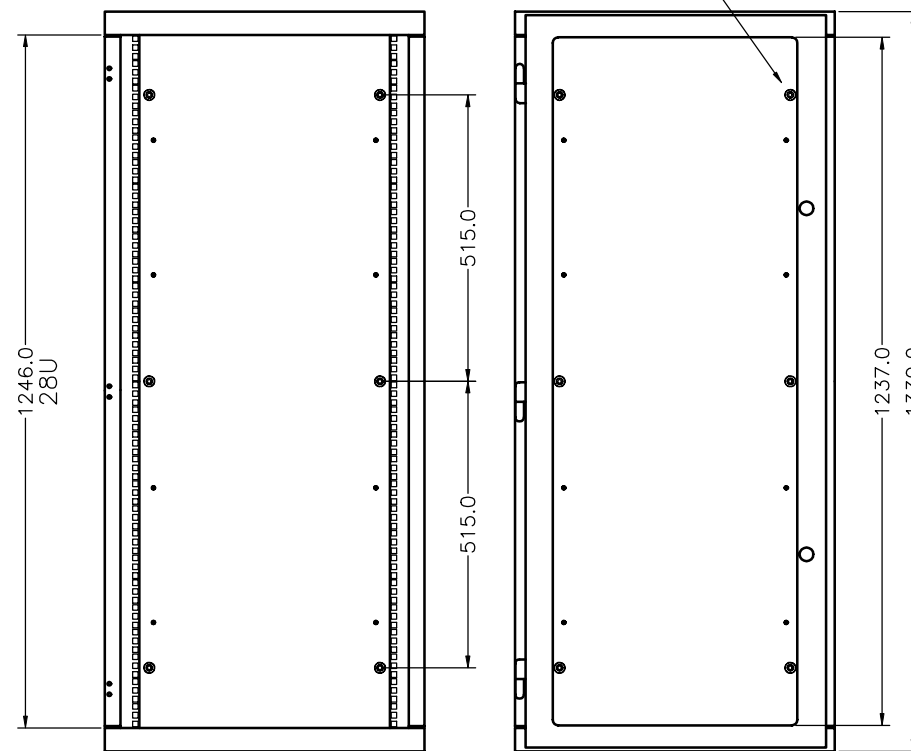

INSIDE VIEW
28U CABINET

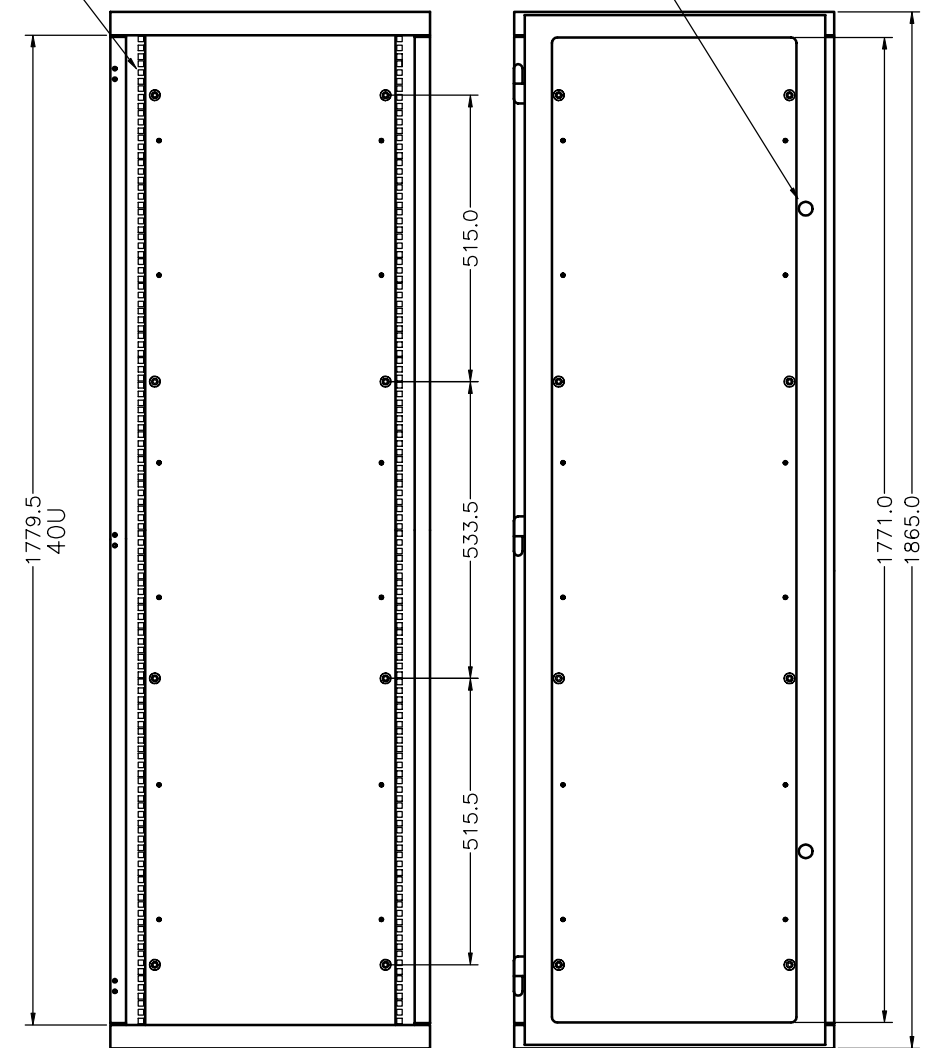

INSIDE VIEW
40U CABINET

UNLESS OTHERWISE STATED: ALL DIMENSIONS IN MILLIMETRES. DO NOT SCALE. TOLERANCES ARE TO BE: 1 DECIMAL PLACE ±0.5, 2 DECIMAL PLACES ±0.3, 3 DECIMAL PLACES ±0.1 CONFIDENTIAL: THIS DOCUMENT MUST NOT BE COPIED NOR THE CONTENTS PASSED ON TO ANY THIRD PARTY WITHOUT THE CONSENT OF THE COMPANY.

ISS/REV	AMENDMENTS	ECO	DRN	CHKD	AUTH	APVD	DATE
A	ORIGINAL	-	DM	RAC	RAC	DSP	9-4-92
B	DOOR DIMS CHANGED	-	KJS				3-8-98

19" RAC CABINETS
PRESENTATION DRAWINGS

VIGILANT
FIRE & EVACUATION SYSTEMS

211 MACES ROAD, CHRISTCHURCH 8006, NZ
P.O. BOX 19-545, CHRISTCHURCH 8030, NZ
PH: +64 3 389-5096 FAX: +64 3 389-5938

SIZE	DRAWING NUMBER	SHEET NUMBER	ISS/REV	PART NUMBER
A1	1919-22	1 of 1	B	

