



FLAMEVision

Array Based Infrared Flame Detectors

The FLAMEVision Flame Detector utilises infrared array based flame detection combined with optional integral CCTV designed to automatically and reliably identify flame incidents and pinpoint the location on a video image.

By using an array as the sensing component, the FLAMEVision detectors are designed to locate the angular position of the fire within the field of view. The detectors use this information to provide superimposed location information on a composite video output from an optional internal CCTV camera and to signal the coordinates of this location on its data output. This information allows the operator to quickly verify the alarm and implement the necessary actions. It also provides a valuable tool for nuisance alarm control and event audit processes.

FLAMEVision Features

- Optional built-in CCTV to assist with rapid response
- Fast, reliable flame detection using infrared detection
- Simplifies alarm handling when monitored from remote control room
- Provides immediate visual ID of alarm location
- Robust housing with heated optics
- Automatic monitoring of detector functionality including signal transmission through window status
- 256 infrared sensor array monitoring the field of view to separately identify flame and non flame sources
- Range of integral interface options
- Masking of part of field of view in software configuration tool
- Over 50m detection range with 90° field of view
- Remote video monitoring with fire location and detector information
- Automatic Optical Integrity Monitoring

The FLAMEVision offers a major improvement in both flame detection capability and immunity to nuisance alarm sources over triple IR detectors. It also includes features designed to reduce maintenance requirements.

The FLAMEVision range of detectors provide, as standard, the following system interface:

- Voltage-free relay contacts for alarm and fault, programmable as normally open or normally closed
- An analogue output current, in the range 4 to 20mA, proportional to the flame detection signal
- RS485 serial data port suitable for network connection using a MODBUS protocol
- Video output compatible with twisted pair video cable

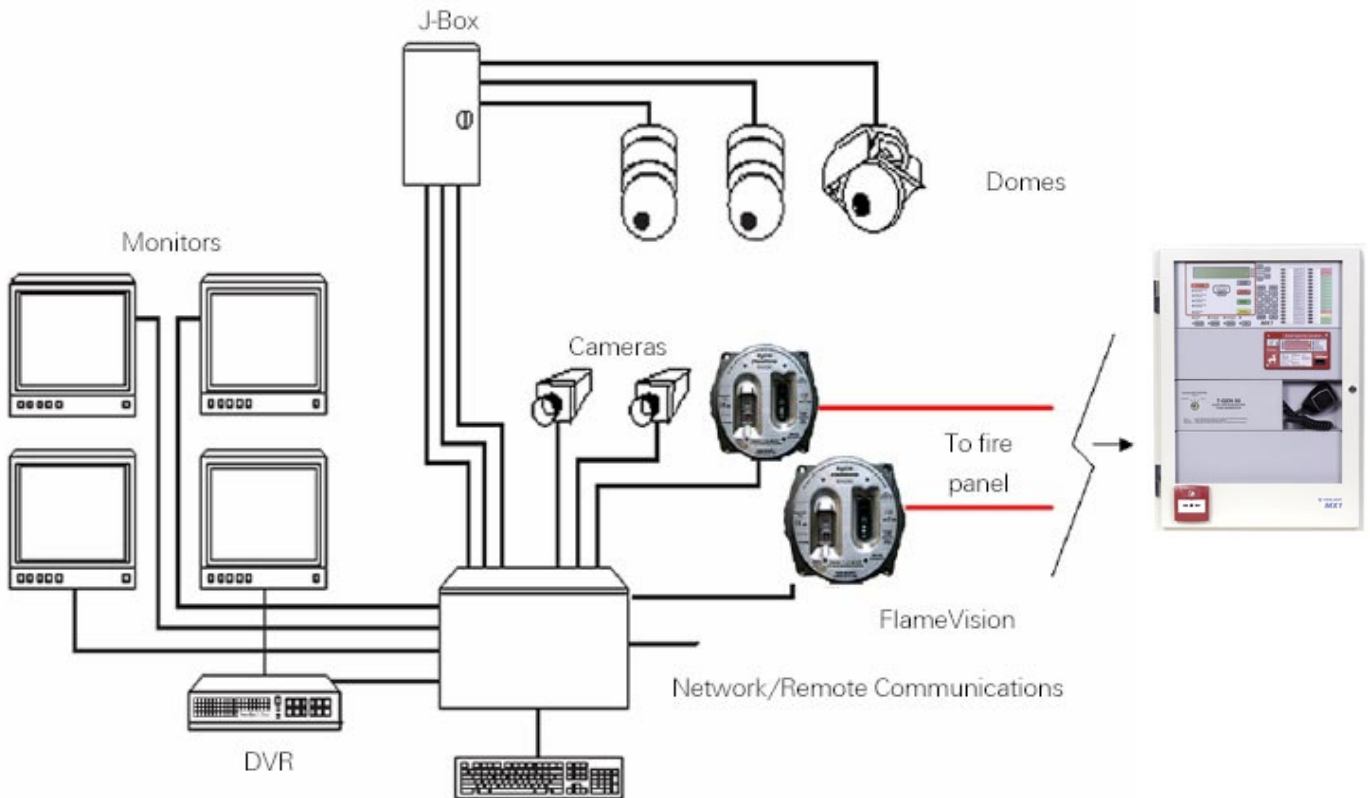

Benefits

- Highly sensitive to flame, thus increasing probability of early detection of hydrocarbon fires over a longer range
- Designed to detect flames through smoke and through high densities of solvent vapours thus increasing the probability of early detection of hydrocarbon fires
- Insensitive to artificial light sources, such as halogen lights
- Consistent, high sensitivity, flame detection throughout a 90° field of view due to 256 individual sensors
- Consistent detection of different types of hydrocarbon fuels from alcohol to aviation fuel with range or size of fire related to calorific value of the fuel
- Pinpoint location of the fire within the field of view enabling more effective counter measures to be taken
- Regular self-testing of critical electronic circuits and regular monitoring of the detector window (OIM) reducing the frequency of regular maintenance visits
- Integral flame simulation for verification of detection path enabling either easy walk-testing of the installation or testing by remote control to ensure continued reliability of the detector operation.
- Options of different system interfaces as standard
- Sealed to IP66 and IP67 (when suitable cable gland and sealant are used) ensuring long term reliability in harsh environments
- Software masking of identified unwanted sources of radiation in the detector field of view



**FLAMEVision alarm superimposed on a CCTV image
(Illustration only)**

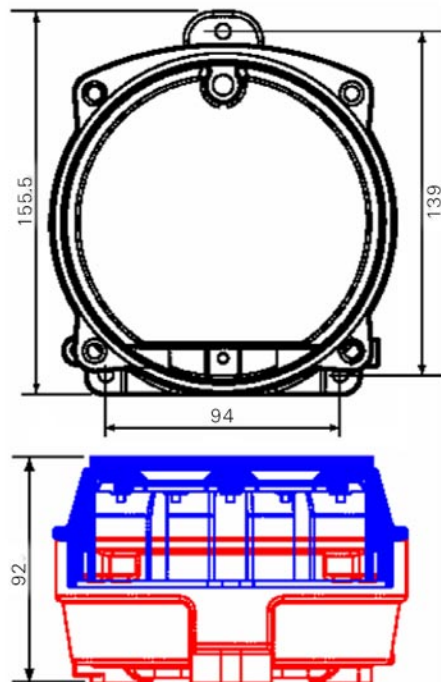

FLAMEVision Dimensions

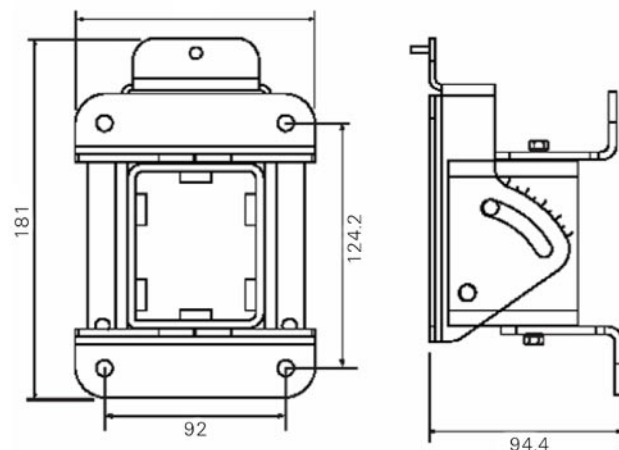

Adjustable Mounting Bracket and Surface Mounting Dimensions

Mechanical Characteristics

Dimensions

| | |
|--------|----------|
| Height | 155.5 mm |
| Width | 152.0 mm |
| Depth | 92.0 mm |
| Weight | 4 kg |

Mounting bracket

| | |
|--------|---------|
| Weight | 1.54 kg |
|--------|---------|

Materials

| | |
|--|--|
| Enclosure | Stainless steel 316L, ANC4BFCLC to BS 3146: Part 2 |
| Detection window | Sapphire |
| Camera window | Toughened glass |
| Guard/label plate | Stainless steel 316S16 to BS 1449: Part 2 |
| Mounting bracket | Stainless steel 316S16 to BS 1449: Part 2 |
| Exposed Fasteners | Stainless steel 316 A4 |
| Electronic modules | Fibreglass substrate |
| Electrical access | |
| FV311 series detectors | Standard M20 gland holes (2) |
| FV312 series detectors | Multi twisted pair screened cable |
| Interface outputs | |
| MODBUS / 4-20mA / Fire and fault relay / Video Out | |

Environmental Characteristics

Temperature

| | |
|-----------------------|-------------------------------|
| Operating temperature | -40°C to +80°C (no camera) |
| Operating temperature | +10°C to +55°C (incl. camera) |
| Maximum temperature | 120°C (for 10 minutes max.) |
| Storage temperature | -40°C to +80°C |

Humidity

| | |
|-------------------|----------------------------|
| Relative humidity | Up to 99% (non condensing) |
|-------------------|----------------------------|

Enclosure Protection

| | |
|----------------------|-------------------------|
| Enclosure protection | Tested to IP66 and IP67 |
|----------------------|-------------------------|

Pressure

| | |
|---------------------------------------|-----------------------|
| Normal operating atmospheric pressure | 910 mbar to 1055 mbar |
|---------------------------------------|-----------------------|

Heat Radiation

| | |
|-------------------------|---------------------------------|
| Heat radiation from sun | 0 to 1kW/m ² typical |
|-------------------------|---------------------------------|

Camera Specification

| | |
|-----------------------------|-----------------------------|
| Composite video | (1V p-p) into 75 Ohm |
| Horizontal resolution | Standard 450 TVL |
| Light Sensitivity (-30 IRE) | 0.3 Lux |
| Iris / Exposure control | Elect. 1/50 - 1/100,000 sec |

Array Based Infrared Flame Detectors

Specifications

Vibration & Shock

The following maximum levels are applicable:

| | |
|--------------------------|--|
| Operational vibration | 1.24 mm displacement (from 5 Hz to 14.2 Hz) |
| | 1.0 g (from 14.2 to 150 Hz) |
| Operational shock/impact | 20.0ms ² |

Electromagnetic Compatibility

Tested to the following levels:

| | |
|---------------------------|-------------------------------|
| Radiated radio frequency | 10V/m (from 80MHz to 2GHz) |
| | 30V/m (from 415MHz to 466MHz) |
| | 30V/m (from 890MHz to 960MHz) |
| Conducted radio frequency | 10V/m (from 150kHz to 100MHz) |
| Fast electrical transient | ± 2kV (applied for 5 minutes) |
| Slow high-energy surge | ± 2.4kV |
| Electrostatic discharge | ± 8kV (air discharge) |
| | ± 6 kV (contact discharge) |

Flameproof Certification

All variants of the FLAMEVision detector are designed to comply with EN 50 014 and EN 50 018 for flameproof enclosures. They are certified: ATEX code: II 2 G Cenelec code: EEx d IIC T4 (-40°C to +80°C) and T5 (-40°C to +65°C) Under ATEX certificate number Baseefa04ATEX0176X. This certification shows the FLAMEVision detectors are certified 'flameproof', meeting the requirements of EN 50014 and EN 540018. They are classified as suitable for zones 1 and 2 areas over an ambient temperature range -40°C to +80°C for temperature class T4 gasses, or up to +65°C for temperature classification T5 gasses. IECEx certificate BAS 07.0048X.

Electrical Characteristics

| | |
|--|----------------------------------|
| Supply Voltage | 20Vdc to 30Vdc |
| Power | up to 10W (depending on model) |
| Current | |
| Quiescent | 158mA @ 24Vdc (no camera fitted) |
| | 196mA @ 24Vdc (incl. camera) |
| Alarm | 166mA @ 24Vdc (no camera fitted) |
| | 205mA @ 24Vdc (incl. camera) |
| Additional current when using 4-20mA output in source mode | |
| Quiescent | 4.0mA @ 24Vdc |
| Alarm | 11.5mA @ 24Vdc |
| Stabilise Time | 5 to 20 minutes after power up |

Ordering Information

Detectors

| | |
|-------------|---|
| 516.300.006 | FV311S cable gland entries no camera |
| 516.300.008 | FV311SC cable gland entries - PAL camera |
| 516.300.007 | FV311SC-N cable gland entries - NTSC camera |
| 516.300.055 | FV312S sealed back box - no camera |
| 516.300.057 | FV312SC sealed back box - PAL camera |
| 516.300.056 | FV312SC-N sealed back box - NTSC camera |

Ancillary equipment

| | |
|-------------|--|
| 517.300.001 | MB300 FLAMEVision Mounting Bracket |
| 517.300.002 | WH300 FLAMEVision Weather Hood |
| 517.300.021 | WT300 FLAMEVision Walk Test Tool |
| 517.300.022 | CTI300 FLAMEVision Off-line Config. Tool |
| 517.300.006 | MK300 FLAMEVision Field Spares Kit |

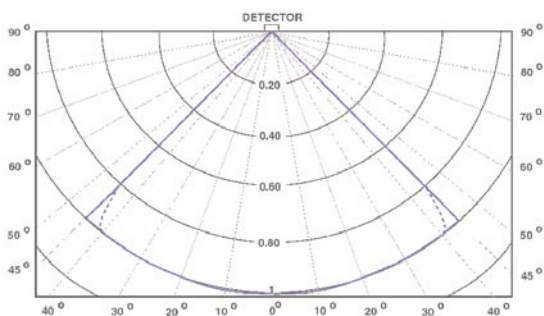

FLAMEVision Coverage Plan - Horizontal

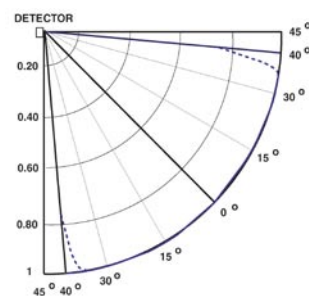

FLAMEVision Coverage Plan - Vertical