

INSTALLATION AND OPERATING INSTRUCTIONS

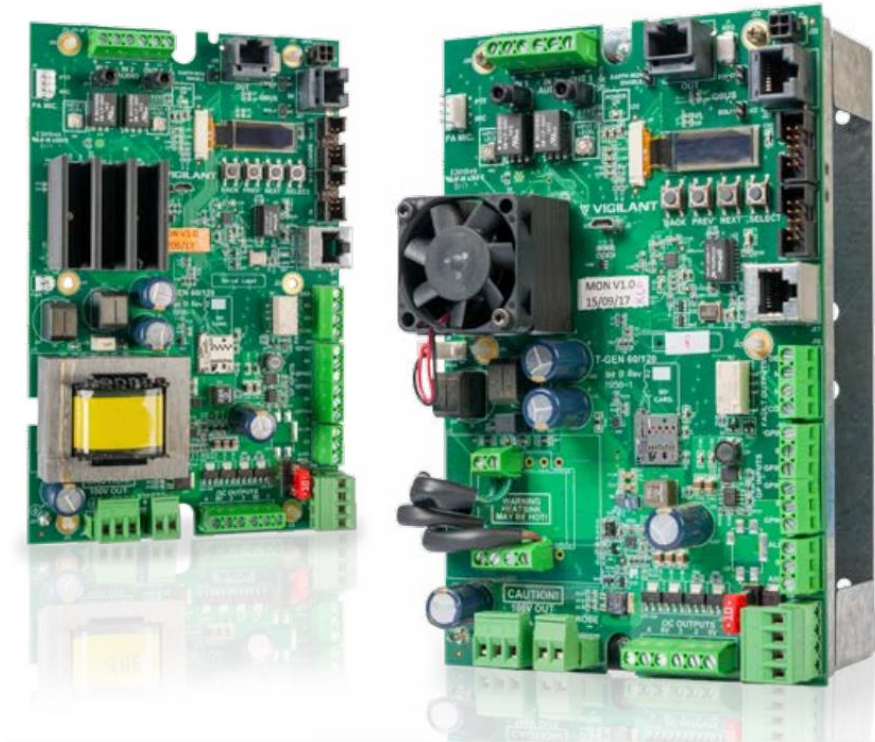

Contents

| | | |
|-----------|---|-----------|
| 1 | GENERAL | 3 |
| 2 | MOUNTING INSTRUCTIONS | 5 |
| 3 | POWER SUPPLY REQUIREMENTS | 7 |
| 3.1 | 2.1 Power Supply Types | 7 |
| 3.2 | 2.2 Power Supply Wiring | 7 |
| 4 | 100V Speaker Line Wiring | 8 |
| 4.1 | 100V Switching Module | 8 |
| 4.2 | 100V Splitter Module | 8 |
| 5 | INPUT/OUTPUT WIRING DETAILS | 9 |
| 5.1 | Earthing | 9 |
| 5.2 | General Purpose Inputs | 9 |
| 5.3 | Audio Inputs 1 & 2 | 9 |
| 5.4 | Audio Output 1 | 10 |
| 5.5 | PA Microphone | 10 |
| 5.6 | Strobe Connection | 10 |
| 5.7 | Fault Relay & DEF- Outputs | 11 |
| 5.8 | QBus Wiring | 11 |
| 5.9 | General Purpose Open Collector Outputs | 11 |
| 5.10 | Slave T-Gen2 Wiring | 12 |
| 5.11 | Slave T-Gen 50 Wiring | 13 |
| 5.12 | T-Gen Wiring – Connection to Vigilant Fire Panels | 14 |
| 5.13 | Fire Panel Wiring – MX4428/F3200/4100ESi | 15 |
| 5.14 | Fire Panel Wiring – Sigma 5, FP1600, Omega 64 | 16 |
| 5.15 | High Level Interface (HLI) | 16 |
| 5.16 | Area Paging | 17 |
| 6 | T-GEN2 CONFIGURATION & OPERATION | 18 |
| 6.1 | Default Operation | 18 |
| 6.2 | Fault Monitoring | 18 |
| 6.3 | Slave Mode | 18 |
| 7 | CONFIGURATION | 18 |
| 7.1 | Jumpers/Hardware Links | 18 |
| 7.2 | Level Controls | 18 |
| 7.3 | Selecting the T-Gen2 Configuration | 18 |
| 7.4 | Downloading a Configuration from SmartConfig | 20 |
| 8 | OLED OPERATION | 20 |
| 9 | COMMISSIONING AND MAINTENANCE | 23 |
| 9.1 | Commissioning Steps | 23 |
| 9.2 | T-Gen2 Amplifier Monitoring | 24 |
| 10 | FIRMWARE UPDATE | 25 |
| 11 | SPECIFICATIONS | 25 |
| 12 | PART NUMBERS | 26 |
| 13 | SUPPLEMENTAL TERMS & LICENSED SOFTWARE | 27 |

1 GENERAL

The VIGILANT T-Gen2 is a self-contained Emergency Warning System (EWS) with 100V speaker line supervision and digitised speech messages. It complies with the requirements of AS 4428.16.

T-Gen2 is available in 2 versions for assembly directly into fire panels or other equipment:

- FP1115** **T-Gen 60:** 60W unit with tones, fault supervision and speech. Has built-in storage for up to 2 minutes of pre-defined messages and tones. A microphone input is available for emergency public address and for recording messages different to the standard messages supplied. A suitable microphone is Part Number ME0290.
- FP1116** **T-Gen 120:** Same as FP1115 except the power output is 120W. It is larger and heavier, so the mounting options are different.



FP1115

FP1116

It is also available assembled onto a 3U 19" rack mounting door, complete with a single-zone Grade 3 User Interface and a microphone; as a complete Grade 3 Building Occupant Warning System (BOWS); and as a 4 Zone Grade 2 Emergency Warning System (EWS).

- FP1121** **3U Door complete with T-Gen 60 & Grade 3 User Interface:** A grey 3U door with a Grade 3 User Interface and a PA microphone, and a T-Gen 60 mounted on the back, ready for installation in fire panels.



- FP1144** **8U Cabinet Building Occupant Warning System:** A titania coloured 8U cabinet with a single-zone Grade 3 T-Gen2 User Interface and PA microphone on a 3U door, with a T-Gen 60 and 14A PSE mounted inside. Able to accommodate an additional T-Gen 60 and up to 3 100V Switching/ Splitter Modules.
- FP1134** **15U Cabinet Building Occupant Warning System:** A titania coloured 15U cabinet with a single-zone Grade 3 T-Gen2 User Interface and PA microphone on a 3U door, with a T-Gen 120 and 14A PSE mounted inside. Space for an additional T-Gen 60 or T-Gen 120 and up to 6 100V Switching/Splitter Modules inside.



FP1134



FP1144

FP1129

15U Cabinet 4 Zone Emergency Warning System: A titania coloured 15U cabinet with a 4 Zone Grade 2 User Interface and PA microphone on a 3U door, and a T-Gen 120, 14A PSE, and one 100V Switching Module mounted inside. Space for an additional T-Gen 120 and up to 6 x 100V Switching Modules inside. Expandable to 20 evacuation zones.



Optional modules that can be used with T-Gen2 are listed on page 26.

These instructions cover the installation and wiring of the T-Gen2 with V2.xx firmware, plus operation of the on-board OLED display and pushbuttons. For installation and operation of the optional modules or assembled systems refer to the following documents:

LT0668 LIT,T-GEN2 100V SWITCHING MODULE INSTALL INSTRUCTIONS
 LT0669 LIT,4100ESi, T-GEN 60/120 MTG BRKT INSTALL INSTRUCTIONS
 LT0670 LIT,4100ESi, 2 X 100V MODULE BRKT INSTALL INSTRUCTIONS
 LT0671 LIT,T-GEN2 100V SPLITTER MODULE INSTALL INSTRUCTIONS
 LT0672 LIT,GRADE 3 USER INTERFACE INSTALLATION GUIDE
 LT0673 LIT,T-GEN2 USER INTERFACE OPERATING INSTRUCTIONS
 LT0677 LIT,T-GEN2 ISOLATION AMPLIFIER INSTALL INSTRUCTIONS
 LT0681 LIT,GRADE 2 USER INTERFACE INSTALLATION GUIDE
 LT0682 LIT,T-GEN2,GRADE 2 UI OPERATING INSTRUCTIONS
 LT0683 LIT,GRADE 2 16Z EXTENDER DOOR INSTALLATION GUIDE
 LT0684 LIT,GRADE 2 8Z EXPANSION BRD INSTALLATION GUIDE
 LT0685 LIT,PSE 14A,GEAR PLATE MTD,INSTALLATION GUIDE
 LT0687 LIT,GRADE 2 EWS INSTALL & OP INSTRUCTIONS
 LT0690 LIT,4100ESi 14A PSE BAY MTG BRKT INSTALL INSTRUCTIONS
 LT0691 LIT,T-GEN2 HLI BOARD INSTALLATION INSTRUCTIONS
 LT0693 LIT,BOWS 60/120W,14A PSU,INSTALL & OP INSTRUCTIONS

Each T-Gen2 needs to be configured for the application it is used in. The T-Gen2 is delivered from the factory with a default configuration, but other pre-defined configurations can be selected using the pushbuttons on the T-Gen2. If a specific configuration is required, this is prepared during the SmartConfig Windows program (version 2.8 onwards).

SmartConfig Lite (SF0323) and its User Manual (LT0345) can be downloaded from the Fireplace:
<http://vigilant-fire.com.au>. Refer Section 7 T-Gen2 Configuration for details.

SYMBOLS USED ON PRODUCT LABELS

The following symbols used on product labels have these meanings:



WARNING: Electrical hazard contained inside. Extra care required if opening.

CHECKING THE KIT

Before commencing installation, please ensure that the following items are present and undamaged:

- 1 x T-Gen2 Board (60W/120W as appropriate)
- 1 x Installation & Operating Instructions (LT0667 – this document)
- 1 x 3k3 resistor ELD for MX4428 & F3200 Ancil Relays
- 6 x 2k7 resistors Alarm, AIE, GP 1-4 Input EOLs
- 1 x 15k resistor 4100ESi NAC output termination
- 3 x 27k resistors 3 branch Strobe ELD
- 1 x 56k resistor 100V line ELD
- 2 x 100k resistors 2 branch 100V line ELD
- 1 x 100V Speaker Line Warning Label (LB0648)
- 220mm heatshrink for sleeving 100V EOL resistors
- 4 x M4 x 10 Screws for mounting T-Gen 120
- 1 x LM0459 loom for MX1
- 1 x 10A fuse for LM0459
- 1 x RJ-45 cable for Slave T-Gen2 wiring
- 6 x Double Barb Standoffs for mounting on some gearplates / side returns
- 6 x 6mm Plastic Standoffs (insert from rear of gearplate)
- 2 x M3 x 8mm M/F Metal Standoffs (MX1 15U gearplate side return mounting)
- 2 x M3 x 6mm Screws (MX1 15U gearplate side return mounting)

2 MOUNTING INSTRUCTIONS

Step 1 In general the T-Gen2 can be mounted in an MX1, MX4428, F3200, 4100ESi, BOWS or EWS cabinet using the mounting holes provided in the cabinet gearplate. The following sections outline the installation.

8U MX1 supports a single T-Gen 60 or T-Gen 120 module on the gearplate.

15U or BTO MX1 supports:

- A T-Gen 60 or T-Gen 120 on the gearplate LHS.
- A T-Gen 60 on the gearplate RHS return fold. Fit 4 x double-barb standoffs and 2 x M3 x 8 M/F metal standoffs.
- An FP1121 3U User Interface complete with a T-Gen 60 on the 19" rack.

To mount the T-Gen 120 on the MX1 gearplate use 4 x M4 screws supplied and the threaded inserts on a 50/65mm (W) x 150mm (H) pattern that are provided for mounting the MX Loop Cards on the gearplate.

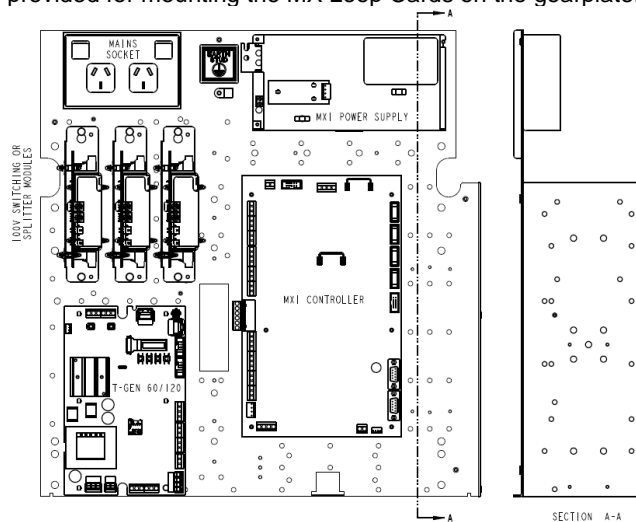

Fig 2.1 Mounting T-Gen2 on MX1 gearplate

8U F3200 The T-Gen 60 can be fitted in 1 of four positions also used for the F3200 8 Zone and 8 Relay Modules.

15U F3200 The T-Gen 60 will mount on the gearplate LHS. The T-Gen 120 does not easily mount on the 15U gearplate – drilling extra holes and using special mounting hardware would be required. Do not fit a T-Gen2 to the cardframe.

15U MX4428 supports a T-Gen 60 on the gearplate LHS.

28U/40U BTO MX4428 In general the ADR/MXP/MPR/T-GEN mounting positions can be used to mount T-Gen2 units, except as follows:

- The positions on the side folds should not be used for T-Gen2 units at all, due to the weight of the T-Gen2.
- The two positions on most gear plates that are hard to the top left-hand side of the gear plate cannot be used for T-Gen 120 as there are mounting nuts underneath that conflict with the T-Gen 120 chassis.

4100ESi 15U Compact Panel supports a single T-Gen 60 on the right hand side fold of the gearplate. A T-Gen 120 will not fit as it's too deep.

4100ESi PDI bays can accommodate up to two T-Gen 60 or T-Gen 120, by mounting each one onto an FP1119 PDI mounting bracket.



Fig 2.2 Mounting T-Gen2 in 4100ESi with APS and 100V Modules

3U 19" rack mounting version (FP1121 or FP1123) can be fitted to 19" rack cabinets using the included mounting hardware, provided there is enough space behind.

BOWS/EWS Use the T-Gen2 mounting positions on the BOWS/EWS gearplate (refer BOWS/EWS instructions).

Step 2. Check the T-Gen2 is earthed– which is usually achieved through the metal mounting screws. The 100V warning label needs to be fitted adjacent to the 100V OUT terminal on the T-Gen2.

Step 3. Connect the T-Gen2 as per the following instructions and the specific panel instructions. All wiring must be kept clear of the heat sink and air should be able to flow freely around it. No part of the cabinet, card frame or wiring must touch the heat sink. With the 120W version all cabling, loose objects, etc., need to be kept clear of the fan to avoid obstructing the fan's rotation.



This is a Class A product. In a domestic environment this product may cause radio interference, in which case the user may be required to take adequate measures.

3 POWER SUPPLY REQUIREMENTS



The T-Gen2s draws significant peak currents when playing the Evacuation and Alert tones. The power supply must be able to supply the peak current without interruption, otherwise the 24V supply to the T-Gen2 may collapse and cause the T-Gen2 to restart.

3.1 Power Supply Types

There are 2 power supply types which are commonly used to power T-Gen2s:

Type 1: In-Line Battery Type

With this type of supply the mains supply is typically a battery charger used to charge the batteries and provide the non-alarm current. The batteries are always connected to the load (e.g., T-Gen2) and are used to provide the alarm and required peak currents. Note the T-Gen2 will not function correctly if the batteries are removed or faulty. These supplies are typically present on older fire panels.

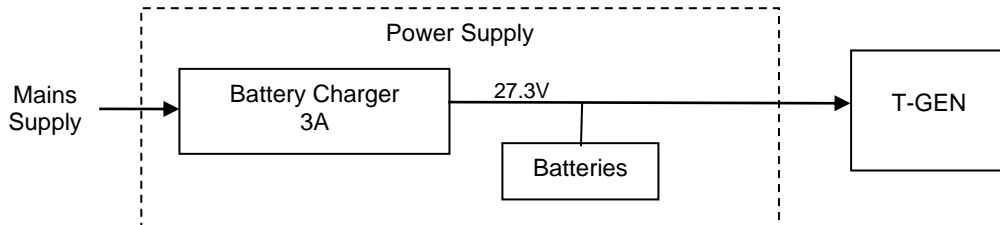

Fig 3.1 In-Line Battery type power supply example (e.g., MX4428 Fire Panel)

Type 2: Switched Battery Type

With this type of supply the mains power supply must be rated to provide the required alarm and peak load current so that the T-Gen2 will function correctly. Should the mains supply fail the power supply will automatically switch over to the batteries. These supplies are typically present on modern fire panels.

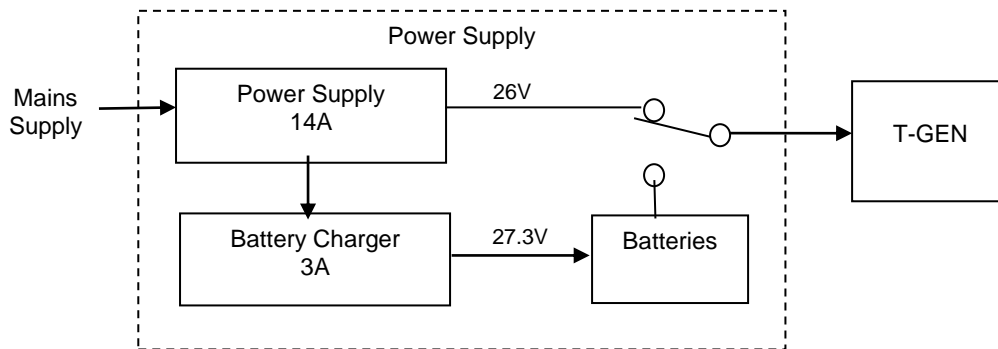

Fig 3.2 Switched Battery type power supply example (e.g., FP1139 14A PSU)



The time taken to switch from the main power supply to the batteries depends on the power supply but typically takes a few milliseconds. During this switchover time the supply to the T-Gen2 can collapse. This is not an issue when the T-Gen2 is in its quiescent state, but if it is playing the Evac or Alert tone it can cause the T-Gen2 to malfunction and the T-Gen2 may reset. This may prevent the T-Gen2 from playing the emergency tones.

3.2 Power Supply Wiring

Note that under AS 1670.1 and NZS4512 the power supply must be able to power the T-Gen2 with no battery connected, i.e., the power supply must be rated higher than the peak currents drawn by the connected T-Gen2s.

On an MX1 panel the T-Gen2 needs to be powered from the LOOP INTERFACE SUPPLY (J33) via a suitable fuse (10A). This lead and a fuse is included with the T-Gen2.

In a 4100ESi panel the power for the T-Gen2 is taken from the PDI backplane or from three VAUX outputs paralleled up on the 4100 APS.

In the T-Gen2 BOWS/EWS systems the FP1139 14A PSE is used.

Refer to Section 11 SPECIFICATIONS for details regarding the T-Gen2's peak current requirements.

4 100V SPEAKER LINE WIRING



The 100V speaker wiring can produce an electric shock when operating, so it is defined as an LV circuit and is subject to the Australian Standard AS/ACIF S009:2013. Ensure that the 100V speaker cabling is appropriately separated and insulated from LV mains power wiring, ELV cabling and other customer cabling such as fire detection and control circuits. 100V speaker wiring is required to be double insulated.

A 100V warning label is provided which should be placed near to the T-Gen2 100V Out terminals.

Note:

The T-Gen2 has 100V line supervision, and therefore requires a DC-decoupling capacitor in series with each speaker transformer. The capacitors must be bipolar, always placed in series with the transformer primary, and have a value of about 1 - 5uF per Watt of the speaker's load (see table below). Many 100V loudspeakers are supplied with a suitable capacitor already fitted.

| Speaker Load | 0.33W - 0.5W | 1W - 5W | 10W - 20W | 40W |
|--------------|--------------|---------|-----------|-------|
| Capacitor | 1uF | 10uF | 47uF | 100uF |

It is possible to use a higher value capacitor on each speaker, however if there are a large number of speakers on the line then T-Gen2 may indicate a fault on power up. This will clear after a few minutes, once the supervision voltage on the line has stabilised. The capacitor's voltage rating must be at least 10V.

For a single line of loudspeakers a 56k resistor ELD is required to be placed at the end of the line. If wiring in two branches, then two 100k ELDs are used, one on each branch. See Figure 4.1 for wiring details.



Any 100V ELD resistors fitted in the cabinet need to be sleeved so that it is not possible to touch the resistor leads.

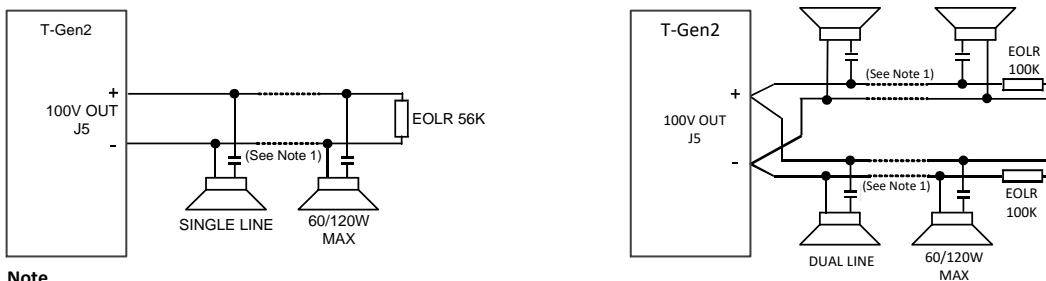

Note

1. Capacitor 10V bipolar. Value 1-5uF per watt of speaker load.

Figure 4.1 100V Speaker Line Wiring

4.1 100V Switching Module

The T-Gen2 has the ability to drive and control 100V Switching Modules to provide switched 100V outputs to up to 4 areas, for example for use with the 4-zone paging console, or in Grade 2 systems to 4 evacuation zones. The T-Gen2's 100V output is connected to the 100V input of the first FP1117 100V Switching Module, and this daisy-chains on to other 100V Switching Modules, with the last one in the chain terminated with a 56k resistor (sleeved for protection).

Refer to LT0668 100V Switching Module Installation Instructions and drawing 1982-71 Sheets 134, 137 and 138 included with LT0668 for further details.

4.2 100V Splitter Module

The T-Gen2's 100V output can be fed into one or more FP1118 100V Splitter Modules to provide 4 x 100V outputs with separate short-circuit isolation. The 100V signal daisy-chains in/out of multiple modules, with the last one terminated with the 56k EOL (sleeved for protection). Refer to LT0669 100V Splitter Module Installation Instructions for details.

5 INPUT/OUTPUT WIRING DETAILS

5.1 Earthing

The T-Gen2 must be connected to the cabinet EARTH using either a metal standoff on the bottom left hand mounting hole (near to J5 100V Output), or the Earth screw terminal on J5.

The 3U Door rack mounting version should be earthed to a cabinet Earth tab using the supplied earth lead.

5.2 General Purpose Inputs

T-Gen2 has 6 general purpose digital inputs: ALM-, AIE-, and GP1 to GP4. Each is programmable for its function and whether open circuit fault supervision is enabled. A contact closure to 0V activates the assigned function. Generally the ALM- input is used to trigger the T-Gen2 into the alarm condition and play the evacuate signal. On some configurations (see Table 7.3) the AIE input is set to play the Alert tone. The AIE and the GPINx inputs can be used to activate the audio inputs for paging, play a recorded message, indicate a fault from an external PSU, amplifier or other equipment, or in Grade 2 systems input alarm conditions for other zones. Each input is configurable for its function using SmartConfig.

Figure 5.2 shows various wiring options and the Section 5.16 shows how to wire up a paging console for area paging.

When supervision is enabled a 2k7 EOL resistor is required to allow open circuit fault detection.

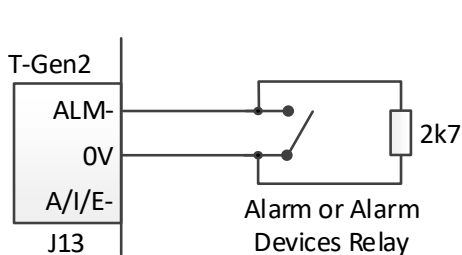

Fig 5.2a Fire Alarm Input Wiring (Supervised)

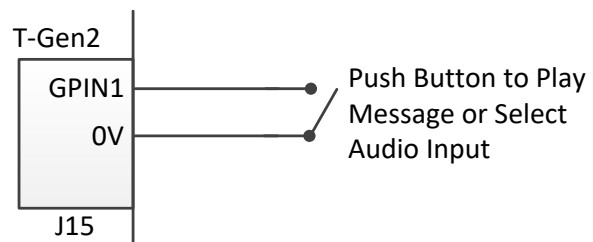

Fig 5.2b Unsupervised Play Message/Input Audio

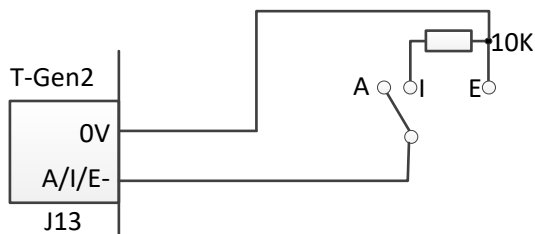

Fig 5.2c Auto/Isolate (Disable) / Evacuate Input

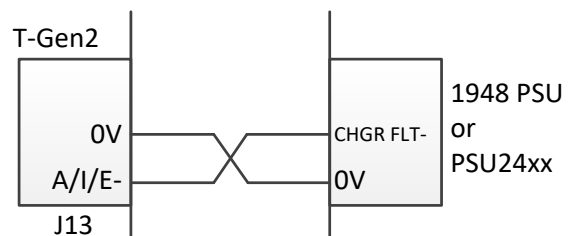

Fig 5.2d AIE Input Used For External PSU Fault

5.3 Audio Inputs 1 & 2

The T-Gen2 provides 2 audio inputs, AUDIO IN 1 and AUDIO IN 2, for functions like background music, paging, etc. Both are available on screw terminals (J12, J10) and AUDIO IN 1 is also available on a 3.5mm socket J11 (only TIP and Ground connections are used). Both inputs are transformer isolated and require a minimum voltage of $\approx 230\text{mV}$ RMS for full volume output. Higher input voltages can be accommodated by reducing the volume through the on-board volume controls (VR2 and VR1 respectively).

Audio sources such as a radio, music player, paging console, internet streaming receiver, microphone with pre-amplifier, etc., can be connected. Each input can be configured as **Always On/Music** (plays if no higher priority input is selected), or **GP/HLL Input** controlled (specific GP or HLL input is active), or **Paging** (a GP input configured for paging is active on V1 firmware).

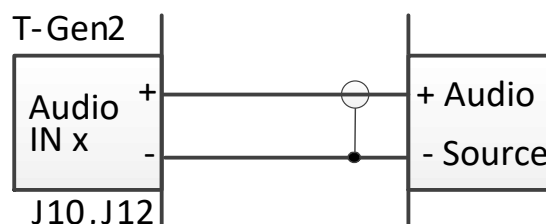

Fig 5.3 Audio Input Connections

5.4 Audio Output 1

The T-Gen2 provides a low-level audio output that is always enabled and will play whatever is being output on the T-Gen2's 100V output. It can be used to drive an external amplifier. Alternatively it could be used as a headphone output to listen to the recorded messages and signals. The OLED Listen commands send the message signal to just this output.

Note if the output is being used for an external amplifier, then the audio will also go to the amplifier(s) when the Listen commands are used. Section 5.11 describes how to use the Audio Output with T-Gen 50 units operating in Slave mode.

5.5 PA Microphone

An emergency PA microphone (part number ME0290 or ME0490) can be connected to J9 on the T-Gen2. For some configurations the microphone is optional, so the connection is unsupervised. For some configurations the connection is supervised as the microphone is included.

J9-1 MIC-
 J9-2 MIC+
 J9-3 PTT
 J9-4 PTT

5.6 Strobe Connection

The Strobe Output provides a three-branch open/short circuit supervised 24V 2A output that can be configured for specific operation.

All default configurations enable the strobe output in the evacuate state. AS 4428.16 signals use a temporal 3 flash pattern synchronised with the tones. AS 2220.1 flashes the strobe at about 1Hz. The output supports wiring to the Simplex 4906-9103 and 4906-9104 strobes, for synchronised flashing. Xenon/LED strobes can also be used with some configurations.

Note a suitable series diode is required for each strobe if none is included in the strobe (these Simplex strobes include one).

Each branch needs to be terminated with a 27k EOL resistor. If only 1 or 2 branches are wired, then the extra ELD resistor(s) should be fitted to the Strobe terminals on the T-Gen2.

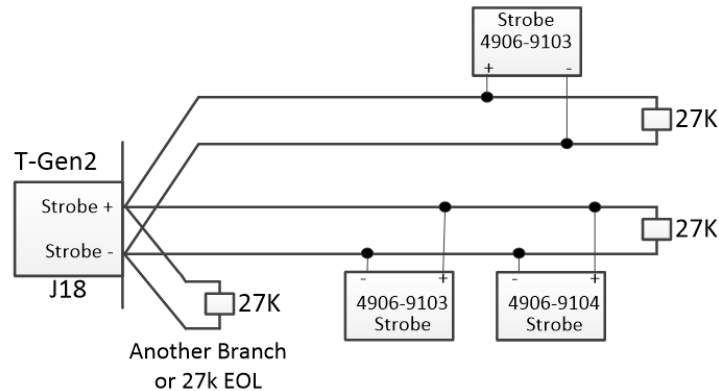

Fig 5.6 Strobe Wiring

Table 5.6 – Multi-branch supervision

| Number of Branches | EOLR on Strobe Output Terminals | EOLR on each Branch |
|--------------------|---------------------------------|---------------------|
| 1 | 2 x 27k | 27k |
| 2 | 27k | 27k |
| 3 | - | 27k |

5.7 Fault Relay & DEF- Outputs

The T-Gen2 provides a normally-energised change-over Fault relay output. When the T-Gen2 is powered down, or it detects a fault condition, the relay is turned off. Various conditions can be selected to cause fault via the configuration.

A DEF- output is also provided (compatible with the EXT DEF- input on some Vigilant NZ fire panels). This open collector output turns on when the T-Gen2 is powered down or detects a fault.

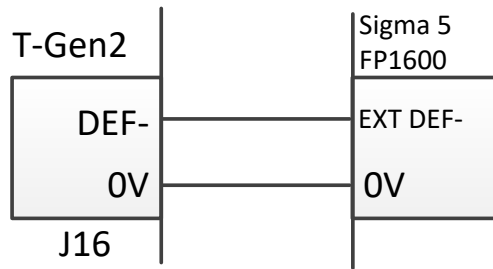

Figure 5.7 DEF- Connection to NZ Panels

5.8 QBus Wiring

The T-Gen2 connects to various optional modules using QBus – a 4-wire combined power and RS485 communications bus. Each QBus module is assigned a unique address, the type of module is included so different module types can each have the same address. The master T-Gen2 is configured using SmartConfig for each QBus module that needs to be connected.

Wiring is essentially free-format – as long as QBus on all modules are inter-connected.

Drawing 1956-38 shows a representative wiring diagram.

Note. The RJ45 connection between T-Gen2 units is also QBus.

5.9 General Purpose Open Collector Outputs

The T-Gen2 provides 2 optionally-supervised (OC 1 and OC 2) and 2 non-supervised (OC 3 and OC 4) open collector outputs that can be configured to turn on for selected conditions.

When supervision is enabled a load pull-up to >12V is required. A Load Supervision fault will be generated if the output voltage is <12V when the output is turned off. This supervision detects a disconnected or un-powered load, or a short to 0V, but does not detect an output short to +24V.

The default configurations provide unsupervised Alarm (OC1) and Fault (OC2) outputs, but specific configurations can select supervision and a different condition.

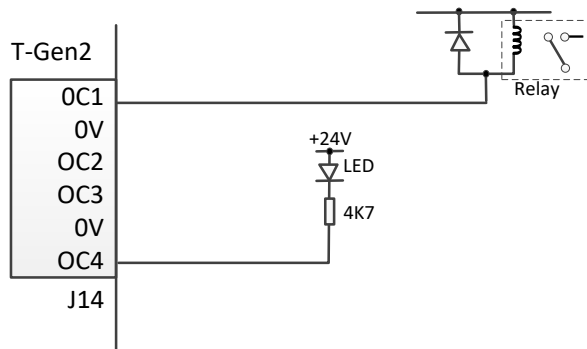

Figure 5.9 Example Open Collector Wiring

5.10 Slave T-Gen2 Wiring

A (master) T-Gen2 can be connected to up to 9 other (Slave) T-Gen2 units to provide additional power output.

The master T-Gen2 must be configured using SmartConfig for each Slave T-Gen2 connected, so it can identify and annunciate faults from each slave. Each Slave T-Gen2 needs to be configured for Slave operation and assigned a unique address (1-9) (refer 7.3 Selecting the T-Gen2 Configuration). The Slave T-Gen2 units need to have V2.xx firmware installed, V1.xx cannot be used.

In a Grade 3 system the 100V and Strobe Outputs on each slave follow the master T-Gen2 with a very small time delay. In Grade 2 systems the slave T-Gens can be assigned to specific zones or functions.

The slaves can operate from separate PSUs and batteries, however the 0V terminals all need to be joined together. Any additional PSUs will need to be monitored for faults, e.g., by using FP1139 14A PSE and configuring them in the master T-Gen2.

The master T-Gen2 is connected, daisy-chain style, to each slave using RJ45 cables from J28 on the master to J27 on the first slave, and from J28 on the first slave to J27 on the next. The order is not important, and no EOL device is required. The master T-Gen2 and all slaves need to be in the same or adjacent cabinets – the cabling is not suitable for external wiring.

The 100V Speaker Output and Strobe Output of each Slave is wired as per the master. The microphone, Audio Inputs, Fault and Def- outputs and open collector outputs of each Slave T-Gen2 are not used and should be left unconnected. The Digital Inputs (including ALM- and AIE) of each Slave can be assigned specific functions using SmartConfig (e.g., Alarm inputs for zones in a Grade 2 system). Use the same wiring as Section 5.2.

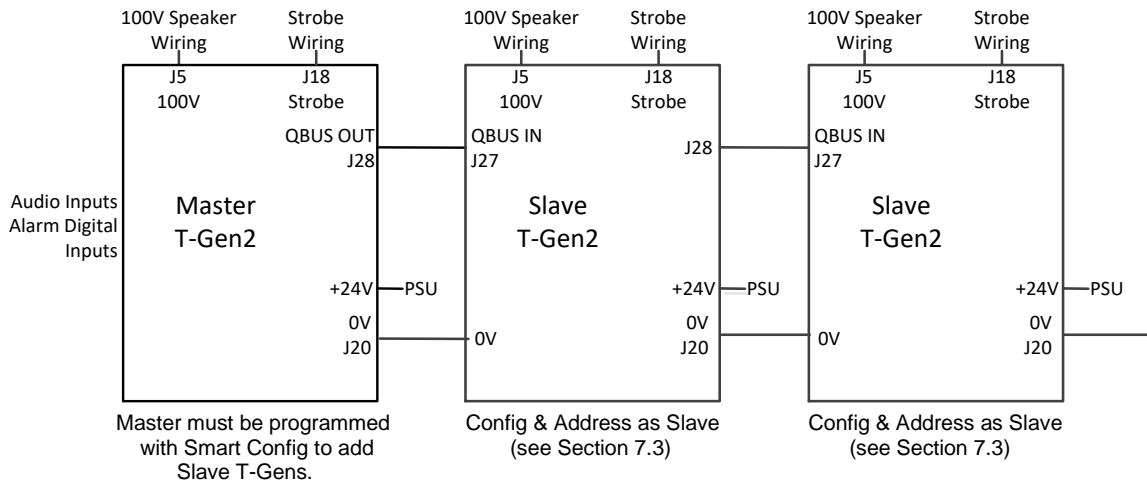

Figure 5.10 Slave T-Gen2 Wiring

5.11 Slave T-Gen 50 Wiring

The low-level Audio Output of the T-Gen2 (J8 OUT1+/-) can be used as the Master audio source for multiple T-Gen 50 units operating in Slave mode.

Note. T-Gen2 cannot be used as a slave to a T-Gen 50 master.

All the T-Gen units need to be co-located and share a common 0V connection. The fault outputs of all the T-Gen units need to be monitored by the fire panel.

This could be achieved by wiring all the Fault relays in series via their NO and COM terminals (all relays are normally energised), or by a GP IN on the T-Gen2 Master being programmed for Ext Audio Fault and wired through the Slave T-Gen Fault relays as above to the 2k7 EOL, or be wired to all of the DEF- outputs, again with a 2k7 EOL to 0V at the last T-Gen 50.

The T-Gen 50 units need to be configured for Slave Mode (Links Lk2, 5, 6 in Slave Mode).

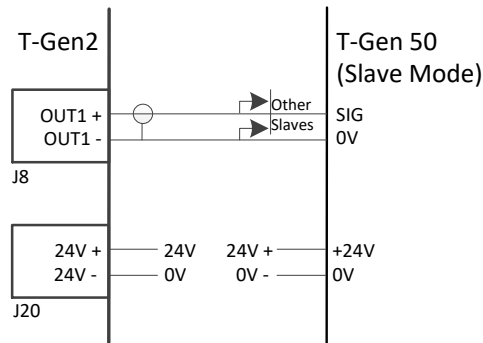

Figure 5.11a Master Audio to T-Gen 50 Slaves

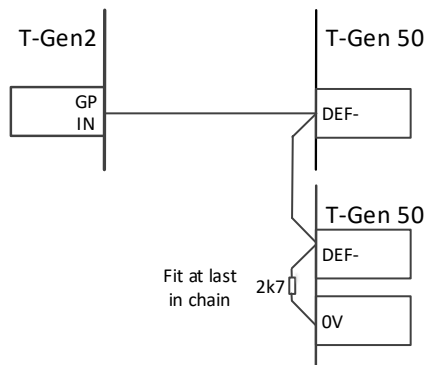

Figure 5.11b Fault Supervision Using DEF- Outputs

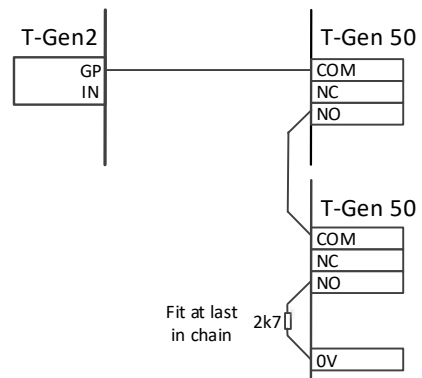
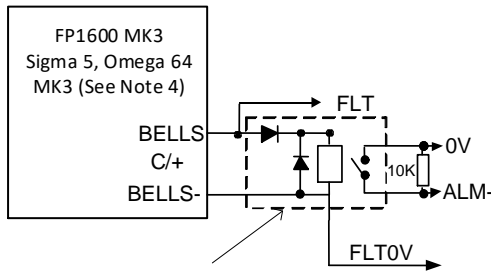
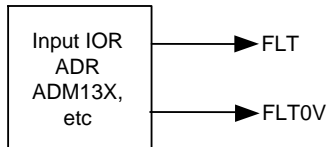
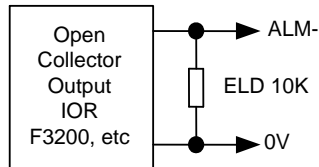
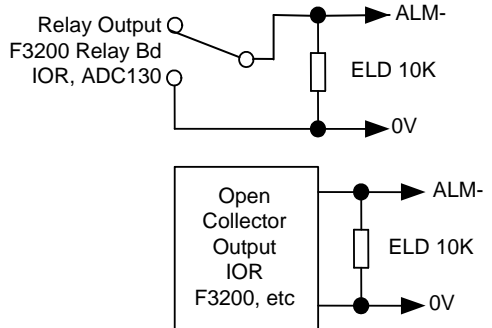
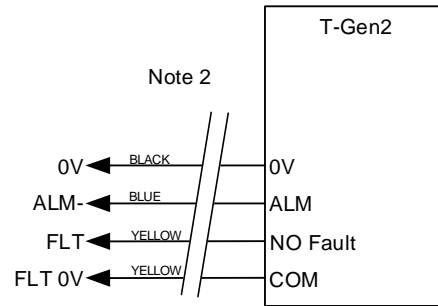
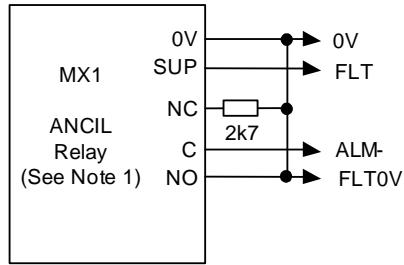
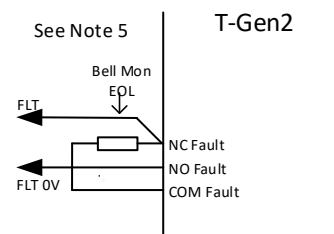
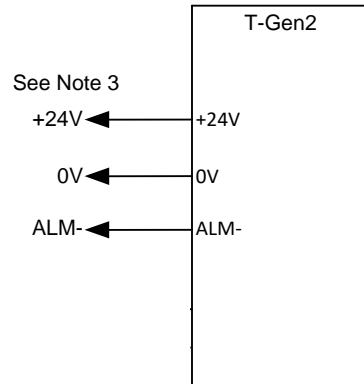

Figure 5.11c Fault Supervision Using T-Gen 50 Fault Relays

5.12 T-Gen Wiring – Connection to Vigilant Fire Panels



E.g., PA0729 GP Relay Board (12V Relay)



Notes:

1. Please refer to MX1 LT0360 Installation Manual (NZ) or LT0439 Operator Manual (Australia) for more information. Use LM0319 (MX1/T-Gen Loom) or FP1121 3U Panel (see Note 2).
2. Refer to Section 3 for 24V power connections. FP1121 3U panel comes with premade loom with connector for MX1 use (ANC1 J4). For use with other panels remove connector and wire as shown above.
3. Requires connection to a suitable monitored 24V supply (FP1600/Sigma 5/Omega 64 Mk3).
4. FP1600/Omega 64 Mk3 boards have three 7-segment displays.
5. EOL resistor to suit Bell Output of fire panel.

5.13 Fire Panel Wiring – MX4428/F3200/4100ESi

MX4428 ANC RELAY/RRM

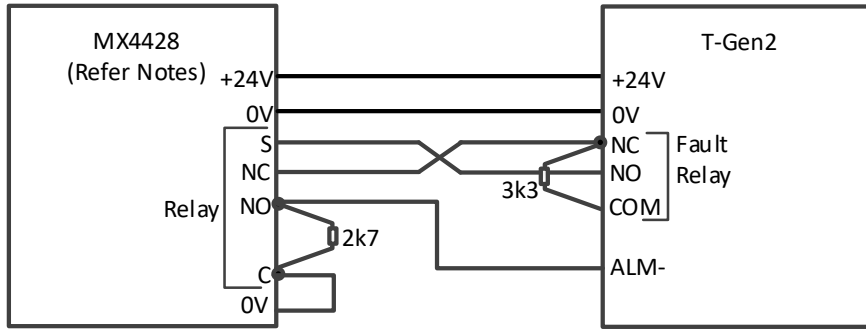

Notes

1. On MX4428 Main Board cut Anc SUP link.
2. On RRM use 24V- terminal on RRM for 0V and connect S wire to RHS S pin of 3-way SUP link (remove link).
3. RRM must be inside the FIP and wired to RESP IN.

F3200

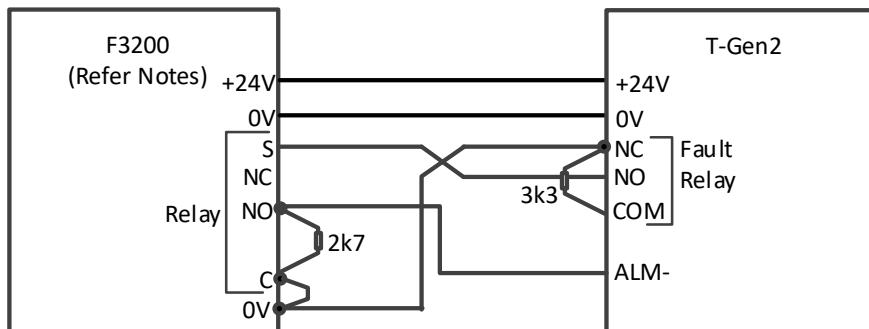

Notes

1. For Ancil 1, 2 Program Supervision Mode = Load (L).
2. For Ancil 3/Bells Program Supervise Act State = N, cut links Lk2, 3, 4. Connect S wire to RHS pin of Lk3.
3. For 8 Relay Module remove SUP jumper and connect S wire to S pin.

4100ESi

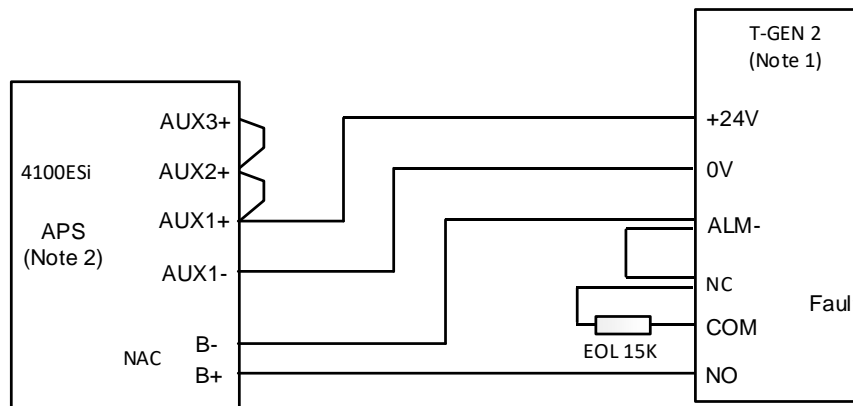

Notes

1. The T-Gen2 needs to be configured for 4100ESi mode, so that the ALM input is unsupervised on the T-Gen2.
2. Wire 3 x AUX power outputs together on APS to provide full power or use:
 - One VAUX output (2A) to power one T-Gen 60 with 40W load and no strobe current.
 - Two VAUX terminals (4A) to power one T-Gen 60 with 60W load and 1A strobe current.
 - Three VAUX terminals (6 A) to power 2 x T-Gen 60 or 1 x T-Gen 120 with full 100V load and no strobe current.
 - NAC3 is recommended as it is set for Alarm Devices in default 4100ESi configs. Other NAC outputs can be used if suitably programmed.

5.14 Fire Panel Wiring – Sigma 5, FP1600, Omega 64

The following wiring can be used when the T-Gen2 is mounted in or adjacent to a Sigma 5, FP1600 or Omega 64 fire panel. The connection uses the DEF- line, which is not supervised for open circuit.

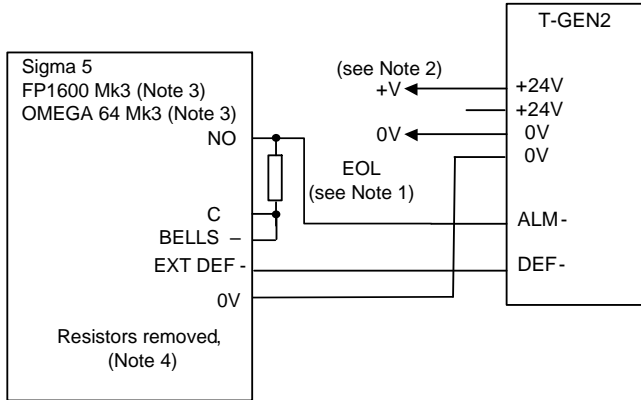

Notes:

1. Sigma 5, FP1600/OMEGA 64 Mk3 - EOL=10k. Enable ALM- input monitoring on T-GEN2.
2. Requires connection to a monitored 24V supply.
3. FP1600/Omega64 Mk3 boards have three 7-segment displays.
4. Sigma 5 and FP1600/OMEGA Mk3 require resistors to be removed. Remove R15, R16 for Sigma. Remove R62, R63 for FP1600/OMEGA 64 Mk3.

5.15 High Level Interface (HLI)

A high-level interface can be fitted between the RZDU port of a Vigilant MX1, MX4428 or F3200 fire panel, or the internal 4100Comms connection of a Simplex 4100ESi, and the T-Gen2 to convey alarm and fault information. The fire panel can send at least 32 signals for alarm triggers, faults, play message, etc., and the T-Gen2 can send its fault status to the fire panel.

Three wiring arrangements are possible:

Direct MX1 RZDU Connection

When no external RZDU devices are connected to the MX1 fire panel and Serial Port 0 is available, a direct 10-way FRC connection can be made from Serial Port 0 on the MX1 to the MX1 COMMS IN connector J29 on the T-Gen2. The MX1 and T-Gen2 must be in the same or adjacent cabinets.

The MX1 must be configured for the RZDU port on an available port (2, 3, 4).

FP1143 HLI Module – RZDU Connection

If an MX4428 or F3200 fire panel is used, or the MX1 has other RZDU devices connected, or Serial Port 0 is not available, the FP1143 HLI Module can be fitted to the T-Gen2 to provide an RZDU electrical interface. It includes a buffered RZDU connection for external RZDU devices, so a wiring fault does not stop the fire panel – T-Gen2 communications. Drawing 1982-71 Sheet 136 (included in LT0691 HLI Module Installation Instructions) shows the wiring. The fire panel and T-Gen2 must be in the same or adjacent cabinets.

FP1143 HLI 4100ESi Connection

The internal 4100Comms port of the 4100ESi panel can be connected to the FP1143 HLI module and T-Gen2, to convey alarm and fault information.

The T-Gen2 appears as an ID-Net slave with a number of input and output devices through which alarm and fault signals can be conveyed.

Drawing 1976-181 Sheet 614 (included in LT0691 HLI Module Installation Instructions) shows the wiring. The 4100ESi and T-Gen2 must be in the same or adjacent cabinets.

Configuration

For an HLI the fire panel will need to be configured to enable the T-Gen2 as an RZDU device/ID-Net slave and to send the appropriate zone/point information to trigger the T-Gen2.

The T-Gen2 will need to be configured using SmartConfig for the appropriate HLI, and to enable the various input trigger conditions.

Refer to the SmartConfig and appropriate fire panel manuals for details.

5.16 Area Paging

By using the A 4488 Paging Console, the A 4489 Audio Switcher, and one or more 100V Switching Modules a 4-area remote paging system can be arranged. The A 4428 Audio Switcher is mounted with the T-Gen2 (e.g., in the bottom left-hand corner of the FP1144 or FP1134 BOWS or FP1129 EWS) and provides relay outputs to the T-Gen2 to signal which areas are to be paged, along with the paging microphone audio signal. One or two remote A 4428 Paging Consoles can be connected to the A 4489 Audio Switcher (using RJ45 cable). The Paging Consoles have a selectable chime option and volume adjustment.

The 100V Switching Modules are connected to the T-Gen2 and switch the 100V speaker output to the various speaker lines depending on which paging areas are active and the assignment of the 100V Switching Module outputs to the various areas. Refer to the 100V Switching Module Installation Instructions (LT0668) for details on wiring them.

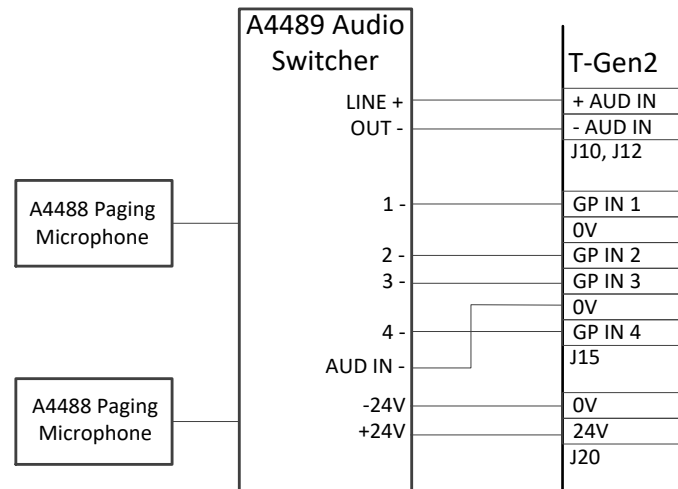

Fig 5.16a 4-Area Paging Console Connections

For T-Gen2 applications with more than 4 areas the Redback A 4585 16 zone audio switch and one or more A 4586 16 zone paging consoles can be used.

The Audio switch could be mounted in the 19" rack of the T-Gen2 cabinet as long as nothing is located behind the audio switch (in 15U cabinets this will mean the batteries will need to be elsewhere).

Connect the console(s) and 24V power to the A 4585 as per its manual.

Connect the PA Out Left or Right signal to the T-Gen2 Audio input assigned for paging. Connect the T-Gen2 0V to FROM PA AMP-, and connect each ZONE- output on the audio switch to each T-Gen2 input assigned for paging to that area. Set the A 4585 Dipswitch 1 ON, 2 OFF. Figure 5-16b shows the wiring arrangement for the first 4 zones. Repeat for the other zones required (multiple T-Gen2 units will be needed for 16 inputs).

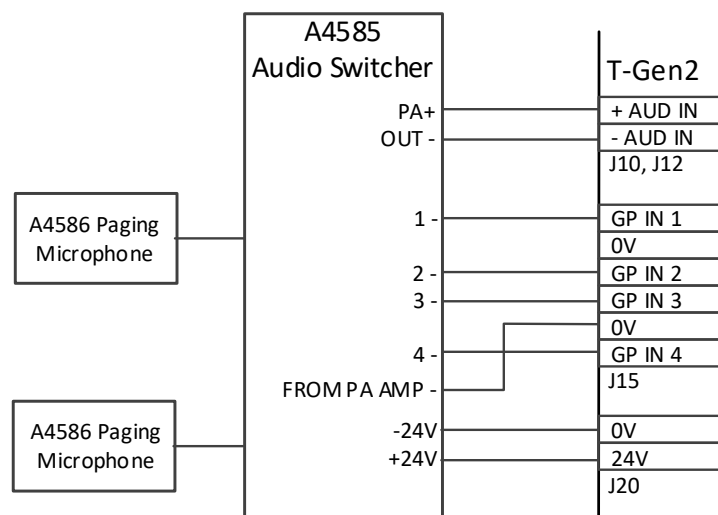

Fig 5-16b 16-Area Paging Console Connections

6 T-GEN2 CONFIGURATION & OPERATION

Operation of T-Gen2 is controlled by the programmable configuration held within it. T-Gen2 is supplied with a number of default configurations, one of which can be selected via the OLED display (see Section 7.3 Selecting the T-Gen2 Configuration). Otherwise a custom configuration can be prepared (and must be if certain optional features are required) via the SmartConfig PC software program and downloaded into the T-Gen2 (see Section 7.4 Downloading a Configuration from SmartConfig).

6.1 Default Operation

T-Gen2 powers up in Auto mode, and will remain in this mode unless a User Interface is connected and Manual Mode is selected. In Auto Mode, an alarm condition (e.g., short circuit on an ALARM input) will trigger the selected Evacuate tone and messages to be played and the Strobe Output to be energised (+24V). These will remain on until the ALARM input goes out of alarm (normal or fault).

6.2 Fault Monitoring

If Fault supervision is enabled on an input (or output), then an open circuit will cause a fault condition. Detection of a short circuit on the 100V and Strobe outputs will also cause a fault condition. A fault condition or power fail to the T-Gen2 will turn the Fault relay off (it is normally energised) and the DEF- output on.

Note that the 100V Output is not supervised for the first 60 seconds after power up to allow the monitoring capacitors to charge up.

Emergency Speech

The operator may use the PA microphone (part number ME0290 or ME0490) for emergency speech. This is activated when the microphone's PTT button is pressed. Speech overrides any Alert and Evacuate tones.

Note some configurations do not supervise the microphone connection as the microphone is optional. With the BOWS/EWS configurations the connection to the microphone is supervised as the microphone is included.

6.3 Slave Mode

Up to 9 T-Gen2 units configured for Slave operation can be connected to a master T-Gen2 to provide additional power output. **The master T-Gen2 will need to be configured using SmartConfig to enable the various Slave T-Gen2 units that are connected.** Each Slave T-Gen2 will need to be configured for Slave mode and the Slave address assigned (see Section 7.3 Selecting the T-Gen2 Configuration).

7 CONFIGURATION

7.1 Jumpers/Hardware Links

| Link | Name | Function |
|------|------------------|--|
| LK1 | Earth Monitoring | Fit for Earth Fault supervision. Remove if PSU, fire alarm panel (e.g., MX1 or 4100ESi), the master T-Gen2, or another device is doing earth fault supervision. Note, Earth Fault supervision will need to be disabled in the configuration as well. |
| LK2 | EOL A | RS485 End Of Line Termination – QBus Audio Channel. Not fitted. |
| LK3 | EOL D | RS485 End Of Line Termination – QBus Data Channel. Not fitted. |

7.2 Level Controls

| Control | Name | Function |
|---------|------------|--------------------------------------|
| VR2 | AUDIO_VOL1 | Audio Input 1 Volume adjust (0-100%) |
| VR1 | AUDIO_VOL2 | Audio Input 2 Volume adjust (0-100%) |

7.3 Selecting the T-Gen2 Configuration

Each T-Gen2 is supplied pre-programmed with a particular configuration as described in Table 7.3. FP1115 and FP1116 are supplied with AS4428; FP1144 and FP1134 are supplied with BOWS-AS4428 ; FP1121 is supplied with 3U-AS4428; FP1129 is supplied with FP1129-Grade 2; FP1135 isolation Amplifiers have Isol Amp.

4100ESi should be selected for T-Gen2 used in Simplex 4100ESi panels, and the AS2220 options should be selected for use in NZ panels.

Table 7.3 – Default T-Gen2 Configurations

| Display Name | Grade | User I/F Present | Description |
|----------------|-------|------------------|--|
| 3U_AS2220 | 3 | Y | Suitable for an FP1121 3U door, or FP1122 or FP1123 doors connected to T-Gen2. Same as AS2220 but with a Grade 3 User Interface and supervised PA microphone input. |
| 3U_AS4428 | 3 | Y | Suitable for an FP1121 3U door, or FP1122 or FP1123 doors connected to T-Gen2. Same as AS4428 but with a Grade 3 User Interface and supervised PA microphone input. |
| 4100ESi | 3 | N | Same as AS4428 except the ALM input is unsupervised to support wiring to a NAC output on the 4100ESi APS. |
| AS2220 | 3 | N | Same as AS4428 except the Alert and Evac tones are AS 2220.1 (NZS 4512) compliant. |
| AS4428 | 3 | N | Suitable for T-Gen2 installed in a fire panel without any optional modules (i.e., speech microphone, 100V Switching Modules, User Interfaces, Slaves, or PSEs). Has AS 4428.16 Alert & Evac tones, non-latching supervised Alarm input generates Evac tone and message, unsupervised AIE input plays Alert tone (no message), no earth fault or Microphone supervision (it is expected the fire panel does the earth fault monitoring), Audio Input 1 is always on, and Audio Input 2 is enabled by GP Input 1. A microphone may be connected, but it is unsupervised. |
| BOWS_AS2220 | 3 | Y | Suitable for use in a Building Occupant Warning System (BOWS) – FP1134 or FP1144. Includes a User Interface, Speech Microphone (supervised), PSE with battery charging enabled, supervised non-latching Alarm input generates AS 2220 Evac tone and message, earth fault monitoring enabled. Audio Input 1 is always enabled, Input 2 is activated by GP Input 1. |
| BOWS_AS4428 | 3 | Y | Suitable for use in a Building Occupant Warning System (BOWS) – FP1134 or FP1144. Includes a User Interface, Speech Microphone (supervised), PSE with battery charging enabled, supervised non-latching Alarm input generates AS 4428.16 Evac Tone and message, earth fault monitoring enabled, Audio Input 1 is always enabled, Input 2 is activated by GP Input 1. |
| FP1129_Grade 2 | 2 | Y | Four zone, Grade 2, emergency warning system as supplied in FP1129. Includes a 4 Zone Grade 2 User Interface, PSE with battery charging enabled, and one 100V Switching Module with each 100V output assigned to a zone. |
| Slave | - | N | Use for a slave T-Gen2. Has supervised 100V and Strobe outputs. Connects to Master T-Gen2 (Grade 2 or 3). Also need to set the slave address. |
| Isol. Amp | - | N | Specific configuration for use in the FP1135 Isolation Amplifier. Select on a T-Gen2 being used as a replacement in this product. |

The configuration can be changed on-site, e.g., to allow use as a Slave T-Gen2 or as a spare part for specific models.

- 1) Power up the T-Gen2 (or re-start it from the Diagnostics Menu) while holding down the SELECT button. This will put the T-Gen2 into Configure mode (it will be in fault and non-operational).
- 2) Press the NEXT button until the **Configure** option is shown, then press SELECT. This will have three menu items – press NEXT to step through and SELECT to use the displayed command.
 - Show Config.** Displays the name of the current configuration on the top line and the Slave Address (0 = Master, 1-9 = Slave) on the bottom line.
 - Select File.** Allows the selection of a new configuration. Press NEXT/PREV to step through the available configurations, then press SELECT to choose the desired one.
 - Set Slave Address.** Allows selection of the Address to use with the Slave T-Gen configuration. An address of 1-9 is for a slave T-Gen, and 0 is needed for Master Mode.
- 3) Power down/up, or re-start the T-Gen2 to use the new configuration.

7.4 Downloading a Configuration from SmartConfig

A specific configuration can be prepared using SmartConfig and downloaded as follows:

- 1) On the T-Gen2 press and hold the BACK button for a least 3 seconds. A display requesting enabling of USB mode is then shown. Press the SELECT button to enable USB mode. (This will stop the normal T-Gen2 operation and a fault will be generated).
- 2) Plug the USB cable from the PC into the T-Gen2.
- 3) Download the configuration from SmartConfig.
- 4) When complete, unplug the USB cable.
- 5) Press BACK on the T-Gen2 to disable USB mode. The T-Gen2 will automatically restart using the new configuration.
- 6) Test the new configuration is correct for the functionality required.

8 OLED OPERATION

The T-Gen2 contains an OLED display and 4 pushbuttons that allow the recall of the T-Gen2's status, fault list, event history, diagnostic voltages/current, and software version details; the activation of Test Mode and a test signal; and the listening, playing, and for recordable ones, the recording of messages.

The OLED automatically switches off after 5 minutes, so press any button to turn the OLED on, if it is off.

The four buttons operate as follows:

| | |
|--------|--|
| BACK | Steps back or exits from the current screen or menu, ultimately to the base display. |
| PREV | Steps backwards through the menu choices or values available for the current item. |
| NEXT | Steps forwards through the menu choices or values available for the current item. |
| SELECT | Selects the currently shown menu item, value or function. |

The base display consists of 3 different layouts – depending on the condition of the T-Gen2:

The NORMAL display shows the T-Gen2 type, firmware version and which of AUTO/MANUAL is currently active.

The FAULTS Present display shows the number of faults present.

The ALARM/EVAC SOUNDING display shows if an alarm is present, the active audio function – ALERT/EVAC/PA or MSG, and ZDIS if the evacuation zone is disabled.

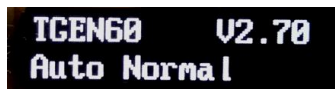

NORMAL



FAULTS PRESENT

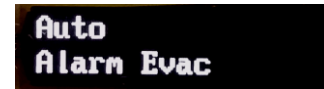

ALARM/EVAC SOUNDING

For V2.7 software or later 'PS' will be displayed at the end of the bottom line on the NORMAL display if the T-Gen is in Power Save mode (T-Gen2's supply voltage < 24.2V).

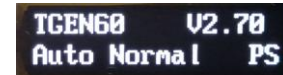

Pressing NEXT, PREV or SELECT at the base display will show the T-Gen2 Main Menu. Press NEXT or PREV to step through the Main Menu items and SELECT to step into that menu. The menu options are: Faults List, Test, Signals, Diagnostics, History and Software; which are described in the following tables.

| FAULTS LIST DISPLAY | |
|---------------------|---|
| Display | Description |
| Master Faults x | Indicates the number of faults (x) on this T-Gen2. Press SELECT to view them. The top line of the fault display shows TM in the centre (for T-Gen2 Master). |
| Slave Faults x | Indicates the number of faults on the 100V Switching Modules, User Interface, PSE and any Slave T-Gen2. Press SELECT to view the faults. The top line of the faults display shows: STx for a fault with a Slave T-Gen2 at address x SMx for a fault with a Switching Module at address x Ulx for a fault with the User Interface at address x PUx for a fault with a 14A PSE module address x |



FAULT ON MASTER

FAULTS ON SWITCHING MODULE OR USER INTERFACE

Most of the fault descriptions are relatively obvious from the text shown. However, some may require an explanation as follows:

| T-Gen2 FAULTS – MASTER/SLAVE | |
|--|--|
| Fault Description | Explanation |
| OCx Mon Flt | Monitoring fault on general purpose output OCx |
| RZDU Comms Flt | RZDU data not received from Vigilant fire panel via HLI |
| 4100 Comms Flt | 4100 Comms data not received from Simplex 4100ESi panel via HLI |
| 4100 CONFIG Flt | Configuration data from Simplex 4100ESi panel is incorrect |
| 100V Cascade Flt | Fault with a 100V Splitter Module or its outputs. |
| 100V Undefined Flt | Undefined Fault – probably two faults present. |
| Amp Mon Flt | The amplifier appears to have failed – but could be due to an overloaded 100V output. |
| Amp IC Flt | An internal fault is present with the T-Gen2 amplifier. The T-Gen2 requires replacement. |
| Supply Low Flt | T-Gen2's supply is below minimum. |
| -5V FLT | Internal fault – replace T-Gen2. |
| 35V FLT | Internal fault – replace T-Gen2. |
| CODEC FLT | Internal fault – replace T-Gen2. |
| SPI FLASH FLT | Internal fault – replace T-Gen2. |
| USB FAULT | Internal fault – replace T-Gen2. |
| SD Card FLT | Config requires Micro-SD card but it is missing, formatted incorrectly or has a file error. |
| QBUS Audio Flt | Slave T-Gen2 is not receiving audio on QBus. Check QBus cabling to Slave T-Gen2. |
| QBUS Data Flt | Slave T-Gen2 is not receiving data on QBus. Check QBus cabling to Slave T-Gen2. |
| Database FLT | Slave T-Gen2 has invalid configuration. |
| Program CRC FLT | Firmware of T-Gen2 CRC check fails. |
| TGEN File Err | T-Gen file is invalid. Try reconfiguring from SmartConfig. |
| Config File Err | Config file is invalid. Try reconfiguring from SmartConfig. |
| Config File CRC | Config file is valid, but CRC doesn't match. Try reconfiguring from SmartConfig. |
| Menu File Err | Menu file invalid. Try reconfiguring from SmartConfig. |
| Menu File CRC | Menu file CRC doesn't match. Try reconfiguring from SmartConfig. |
| WAV File CRC | A recorded message file CRC is incorrect. Try reconfiguring from SmartConfig. |
| Output O/L Flt | 100V output is overloaded, amplifier output is reduced. |
| WDOG Restart | T-Gen2 microprocessor has restarted due to a watchdog timeout. |
| Silenced Warning | The Silence Warning function has been activated on the user interface |
| SWITCHING MODULE/USER INTERFACE FAULTS | |
| Comms Fail | 100V Switching Module (SMx) or User Interface (UIx) is not communicating with T-Gen2 – check cable, configuration, and addressing of module. |
| CRC Fail | Program faulty. Replace module. |
| Software FLT | Program faulty. Replace module. |
| Restart | Temporary Restart. If doesn't clear replace module. |
| B Restart | Temporary Restart. If doesn't clear replace module. |
| W Restart | Temporary Restart. If doesn't clear replace module. |
| Config Error | Configuration Error. If doesn't clear replace module. |
| Stack Overflow | Temporary Software Fault. If doesn't clear replace module. |
| Stack Underflow | Temporary Software Fault. If doesn't clear replace module. |
| 14A PSE FAULTS | |
| Thermometer Flt | Temperature probe disconnected/shorted |
| Battery O/C | Battery open circuit/disconnected |
| Battery Low | Battery voltage low (<24.2V) |
| Battery Fail | Battery voltage failed (<21V) |
| Battery CAP Fail | Battery capacity low – failed long term test |
| Battery Flat | Battery voltage flat (<18V) |
| Charger Flt | Charger voltage out of specification |
| Factory Config | PSE has lost factory configuration |
| Software Flt | Internal fault in PSE. Turn PSE off completely (no mains, no battery) and on again. If returns replace PSE. |
| OTHER EVENTS (non-faults logged to the history) | |
| Power Save | The T-Gen is in Power Save mode due to a low supply voltage |

| TEST MENU | |
|------------------|--|
| Display | Description |
| Test Tone | Press SELECT to activate a 1kHz sine wave to the 100V output. The current volume is shown (0-100%). Press NEXT to increase and PREV to decrease the volume. On a Grade 2 system it will be necessary to select which zones are to receive the test tone – press the Zone SPEECH button to enable. |
| Test Mode | Press SELECT to activate Test Mode. The top line shows the Test Mode on/off status. In Test Mode the T-Gen2 operates as usual, but no sounds (except Speech) or strobe activations are generated. This allows the operation to be tested (e.g., press ALERT/EVAC if a User Interface is present) or observe the operation when an alarm is received. Press SELECT or BACK to turn off Test Mode. |

| SIGNALS MENU | |
|---|---|
| Display | Description |
| AS 2220 ALERT AS 4428.16 ALERT, etc. | Shows the name of each of the Signals present in the configuration. Press SELECT to select the Signal for the following functions. |
| Listen Audio 1 | Listen to the Signal via the low-level Audio Output 1 (e.g., via a head set or external device). The volume can be adjusted through 0-100% by pressing NEXT/PREV. Note this will stop the 100V output and the Signal (tones/messages) will be played to any devices (e.g., external amplifier, T-Gen 50 Slave) connected to the AUD OUT1 J7/J8. |
| Play 100V Line | Plays the signal to the 100V output and to the Strobe output. Allows testing of the signal, sound level measurement, etc. The volume can be adjusted through 0-100% by pressing NEXT/PREV. |
| Record | Allows the message to be re-recorded if enabled in the configuration. |

| DIAGNOSTICS MENU | |
|-------------------------|--|
| Display | Description |
| Supply Voltage | Press SELECT to show various input and internal voltages or currents on the master T-Gen2. Press NEXT/PREV to step through: Power Voltage – the supply voltage to the T-Gen2. P35V Voltage – the internal 35V for the amplifier. AMP Current – current (amps) drawn by the amplifier. AMP 22K Mon – The 22kHz amplifier monitoring tone level. ALM Input Volt – voltage on Alarm Input. AIE Input Volt – voltage on A/I/E Input. GPInput 1 – voltage on GPIN1. GPInput 2 – voltage on GPIN2. GPInput 3 – voltage on GPIN3. GPInput 4 – voltage on GPIN4. Minus 5 voltage – minus 5 voltage for Strobe/Supervision. OC1 – voltage on OC1 output. OC2 – voltage on OC2 output. |
| PSU Voltage | Press SELECT to show various voltages and currents from each of the configured 14A PSE modules (x = PSE address 1-9) Press NEXT/PREV to step through: PUx PSM – Incoming DC voltage PUx Battery – Battery voltage (sampled every 30s) PUx Charger – Charger voltage PUx Output – System output voltage PUx Load Cur Pk – Peak (last 5 sec) output current PUx Load Cur Avg – Average output current PUx Charger Cur – Charger current PUx Temperature - Temperature |
| Time Date | Press SELECT to display the current time and date. Press SELECT to enter Date and Time entry mode. This shows the different date/time values that can be set. Press SELECT to enter the set mode for the value shown (e.g., year). Press NEXT/PREV to change the value and then SELECT to save the value and display the next field. Repeat the process to enter the date, then the time. Press BACK twice to show the current time and date. |
| Format Disk | Formats the internal flash memory that stores the configuration. Use this command only if the contents must be cleared and the memory reformatted. This is needed if the firmware is downgraded, e.g., from V2 to V1. The T-Gen2 will not work afterward and will need to be reconfigured using SmartConfig. |
| Restart T-Gen | Restarts the T-Gen2. |

HISTORY MENU

The T-Gen2 keeps a time-tagged history of the fault and activation events since it was turned on. If the time and date is set via the Diagnostics Time Date command, then the events are tagged with the actual time/date, as well as how long ago the event occurred. The most recent event is shown as Event 1, with the oldest as Event x. Press SELECT to show the most recent event on the OLED.

| |
|-------------------------|
| Event 1/y Event text |
|-------------------------|

This shows the event number (1), and the number of events (y), plus the event text on the second line. Press SELECT to show the time and date of when the event occurred.

| |
|-------------------------|
| Evt Time H:M:S D/M/Y |
|-------------------------|

Press SELECT to show how long ago the event occurred. This shows the number of days (D) and the hours, minutes, seconds ago the event occurred (so it continuously increases).

| |
|------------------------------|
| Evt Elapsed Time xD H:M:S |
|------------------------------|

Press SELECT to show the Event text again. Press NEXT on any history screen to show the next (older) event and PREV to show the first event (event y) or the newer event if the newest is not being shown already.

SOFTWARE MENU

| Display | Description |
|--------------|--|
| Firmware | Pressing SELECT displays the firmware version and CRC for the T-Gen2; and pressing NEXT/PREV steps through the firmware version for each of the 14A PSE, User Interface, Slave T-Gen2 and 100V Switching Modules that are configured, connected and operational. |
| Config File | On the first page the system name of the configuration is shown. Pressing NEXT displays the second page, which shows the time and date the configuration file was created. Pressing NEXT again shows the internal version and format. |
| Menu File | On the first page the time and date the menu file was created are displayed. Pressing NEXT displays the second page, which shows the version and format of the menu file. |
| Memory Usage | Displays the internal flash memory usage for the configuration, messages, etc. The first value is the number of k bytes used, the second is the maximum available (not all will be available as some is needed for folders, etc.). |

9 COMMISSIONING AND MAINTENANCE

9.1 Commissioning Steps

The suggested steps for commissioning a T-Gen2 system are as follows:

- Configure the T-Gen2 and other modules required, using these and the other module installation and configuration instructions. Check the wiring is correct.
- With the T-Gen2 and any 100V Switching and Splitter modules powered down, disconnect the 100V line from the T-Gen2's 100V Output and measure the 100V line's impedance using a suitable meter. Check that the impedance is greater than that shown in table 9.1.

Table 9.1 Minimum Load Impedance

| T-Gen2 | Minimum Load Impedance (ohms) |
|------------------|-------------------------------|
| FP1115 T-Gen 60 | 170Ω |
| FP1116 T-Gen 120 | 85Ω |

Note that the maximum load that can be connected to a switching / splitter module's output is 100W (100 Ω).

- Power up using Mains only and check the operation.
- With V2.7 software or higher check the 22kHz tone level as per section 9.2.
- Correct any fault conditions identified (except missing battery for now).
- Test the alarm inputs, output mapping, strobe outputs, etc.
- Adjust the volume of any AUD1 and AUD2 input signals.
- Test each zone function (alert, evacuate, speech) and non-emergency functions (BGM, paging) can be heard in the required zones / areas.
- Test the phased evacuation if programmed (e.g., use Test Mode).
- Connect the batteries.

When measuring the sound levels in the various areas, record the sound level of the test tone at a particular level so this can be used in the yearly tests to AS 1851 Items 3.9 and 3.10.

For testing to AS 1851, Test Mode can be used to check alarm operation on the T-Gen2 from the fire panel and MCPs, without activating warning signals to the building.

The Test Tone can be used to check speaker operation at a low sound level.

For service and maintenance use the OLED buttons and display to show the details of any fault conditions. The History menu can be used to see transient fault events.

9.2 T-Gen2 Amplifier Monitoring

The T-Gen2 includes circuitry to monitor its amplifier as shown in figure 9.2.

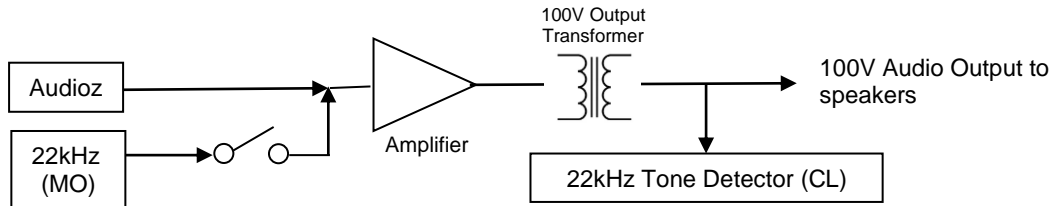

Fig 9.2 Amplifier Monitoring

The T-Gen2 uses a 22kHz tone (frequency too high to hear over the speakers) which it applies to the input of the amplifier at a low level. A tone detector circuit at the 100V Output is used to detect the 22kHz tone. This tone is turned on for a few seconds every 30 seconds. If the tone detector does not detect the 22kHz (e.g., due to an amplifier fault) it will generate an Amplifier Monitoring fault.

T-Gen2s with V2.5 software or earlier use a fixed level 22kHz tone applied to the input of the amplifier. The voltage of the tone on the line varies between about 1 and 10Vrms depending on the speaker line capacitance. T-Gen2s with V2.7 or higher software gradually increase the level of the 22kHz tone until either the T-Gen2 detects the test tone on its 100V Output (at which point it will turn off the tone) or it reaches its maximum tone level. If it reaches its maximum level without detecting the tone it will generate an Amplifier Monitoring fault. This has the advantage of automatically adjusting the 22kHz tone voltage on the 100V Output according to the load and avoids excessive tone levels which can cause a faint click noise on the speakers about every 30sec.



Note that if there is too much capacitance on the 100V line the T-Gen2 may not detect the 22kHz test tone and it will generate an Amplifier Monitoring fault. The T-Gen2 may also not be able to drive this load when playing the Evacuation or Alert tones. Refer to Section 11 Specifications for the maximum load capacitance. Note the load capacitance is determined by the type and length of the speaker cable and type and number of speakers.

T-Gen2s with V2.7 or later software include a diagnostic screen which can display the current level of the 22kHz tone as measured by the tone detector circuit on the 100V line and the level of the tone required by the T-Gen2 to detect the tone at the 100V Output.

The diagnostic display on the OLED is as follows:

AMP 22K Mon:
CL-xx MO-yy

Where:

xx is the current level on the line as measured by the tone detection circuit.

yy is the level of the 22kHz signal (0-100%) applied to the input of the amplifier required to generate a current level of 100.

The current level (CL) is a value between 0 and 1000 and is proportional to the 22kHz tone voltage on the 100V line. E.g., 0 = ~0Vrms, 100 = ~1Vrms. T-Gen2 requires the current level to reach at least 100 (~1Vrms on the 100V Output) before determining that the amplifier is working correctly.

The MO (Maximum Output) value is the % of full scale tone required to be applied to the input of the amplifier to generate a current level of 100. Typically, this is less than 30%. If the MO is above 80% the load has too much capacitance and you might get random Amplifier Monitoring faults occurring. If the MO is above 90% the amplifier will generate an Amplifier Monitoring fault.

For short cable lengths the CL may be greater than 100 with no test tone applied. In this case an alternative monitoring method is used.

For cable lengths of about 100m or longer the current level will usually be below 100 (typically 1 or 2 for >200m) and every 30sec will increase to about 100 then drop back down.

In the following example the Current Level is '1' and the Maximum Output is 26. 26% is well below 80% so the load capacitance is acceptable in regard to amplifier monitoring.



This display is accessed via the Diagnostic – Supply Voltages menu.

10 FIRMWARE UPDATE

New firmware may be made available for the T-Gen2 – see the Fireplace website <http://vigilant-fire.com.au>
This can be installed using SmartConfig – refer to the SmartConfig Help file or User Manual for instructions.

11 SPECIFICATIONS

| FP1115 / FP1116 | |
|---|--|
| Weight | 0.65kg / 1.5kg |
| Size | 125x195x55mm / 125x195x110mm |
| Supply Voltage | 19.2Vmin - 28.8Vmax |
| Operating Temperature Range | -5C to +45C |
| Relative Humidity | 0 to 95% non-condensing |
| Storage Temperature Range | -20C to +70C |
| Quiescent Current | |
| Audio enabled but idle (no signal) | 170mA |
| Active Current - 60W/120W (excluding strobe current) | 3A @ 27V, 4.5A @ 20V / 6A @ 27V, 9A @ 20V |
| Avg Alarm Current (excludes Strobe) | |
| AS4428.16 Tones Selected | 1A @ 60W / 2A @ 120W |
| AS2220.1 Tones Selected | 2.4A @ 60W / 4.8A @ 120W |
| 100V Output | |
| Line Power - Tones | 60W / 120W |
| - Audio | 60W / 120W |
| Maximum line capacitance | 200nF |
| Audio Frequency Range | |
| +/- 1dB | 260Hz – 3800Hz |
| +/- 3dB | 215Hz – 8400Hz |
| Audio Performance | |
| Signal to Noise Ratio | ≥75dB(A) |
| Total Harmonic Distortion | ≤0.25% |
| 100V Speaker Line Supervision | |
| ELD - 1 Branch | 56k 0.4W |
| - 2 Branches | 100k 0.4W |
| Strobe Output | |
| ELD - 1 to 3 branches | 1x10k - 3 x 27k 0.4W |
| Current rating (add to Active Current above) | Max 2.0A |
| Audio Inputs | |
| Audio 1 & Audio 2 | 230mVrms (min) into 5kΩ isolated for full power |
| Microphone - Input Level | 3mV - 100mV rms, PTT driven, optionally supervised |
| Digital Inputs | |
| Input Voltage Range | 0-30Vdc |
| Supervised | 2k7 EOL, <3.5V Active, O/C Fault |
| Unsupervised | <3.5V Active |
| Open Collector Outputs | |
| Off State | 30Vdc max |
| On State | <1V @ 100mA max |
| Supervision | <12V in off state will cause fault |
| Fault Relay | Normally Energised |
| | Change-over relay, 30Vdc <2A |
| DEF- Output | <1V @ 100mA max in fault |
| | 30Vdc when off |
| Interfaces | |
| OLED, 4 button menu structured | |
| QBus compliant | Master / Slave operation, User Interface and 100V Switching Module system integrated |
| On-board Storage | 4Mbyte (configuration and audio files) |
| Micro-SD Card | 32GB max size FAT32 support |
| Headphone Output | |
| Load Impedance | 8Ω min 6mW |
| Output Level | 1.3Vrms |

12 PART NUMBERS

FP1115, FP,T-Gen 60,24V,C/W INSTALL LIT & MTG

T-Gen60 model of T-Gen2 able to drive a speaker load up to 60W. Supports two non-emergency audio inputs (BGM, paging), a microphone audio input (Speech or Paging), 6 supervised inputs (Alarm, Fault, Paging), 4 open-collector outputs, normally-energised Fault relay, supervised single polarity strobe output, and 100V speaker output.

FP1116, FP,T-Gen 120,24V,C/W INSTALL LIT & MTG

T-Gen120 model of T-Gen2 able to drive a speaker load up to 120W.

FP1117 FP,100V SWITCHING MODULE,C/W LIT,LOOMS & MTG BRK

Provides 4 supervised, short-circuit isolated 100V outputs (each rated at up to 100W) from the T-Gen2's 100V output, along with control of each output by the T-Gen2 to provide area paging. A QBus slave module. Supplied on *MX1*-style mounting bracket with cables and EOLs.

FP1118 FP,100V SPLITTER MODULE,C/W LIT,LOOMS & MTG BRKT

Provides 4 supervised, short-circuit isolated 100V outputs (each rated at up to 100W) from the T-Gen2's 100V output. No control of the outputs is available. Signals fault to the T-Gen2 by superimposing a fault on the T-Gen2's 100V input. Standalone operation (not a QBus slave). Supplied on *MX1*-style mounting bracket with cables and EOLs.

FP1119 FP,4100ESi,T-GEN 60/120 BRKT,C/W POWER LOOM & LIT

This metal plate provides mounting for 1 x T-Gen2 (60W or 120W) in a 4100ESi PDI backplane. Two FP1119 plates, one ME0504 APS and one FP1120 100V Switching Module bracket can be mounted in a PDI backplane. The kit includes mounting hardware and a loom to connect the Signal Power voltage on the PDI backplane to the T-Gen2's 24V terminals.

FP1120 FP,4100ESi,2 X 100V SWT MODULE BRKT,C/W LIT & MTG

This metal bracket mounts (legacy-style) in the 4100ESi PDI backplane to provide mounting for up to 2 x FP1117 100V Switching Modules or 2 x FP1118 100V Splitter Modules (or one of each).

FP1121, FP,GRADE 3 EWS UI 3U DOOR,C/W T-Gen 60 & MIC,GREY

A grey 3U 19" rack mounting door complete with a T-Gen60 mounted on the back of it. A microphone and front panel User Interface are supplied fitted to provide a complete functional unit. A loom for connection to *MX1* Controller for power, control and monitoring is factory fitted. Wiring to the 100V speaker and Strobe line is required to make it operational.

FP1122 FP,GRADE 3 EWS UI 3U DOOR,C/W LOOM & MIC,GREY

A grey 3U 19" rack mounting door complete with a Grade 3 user interface and PA microphone ready for connection to a T-Gen60 or T-Gen120 mounted inside the cabinet. A 1.5m power loom and microphone extension loom are included, long enough to connect to the T-Gen2 mounted on the gear plate in a 40U deep cabinet, for example. Suitable for mounting in an *MX1* fire alarm panel.

FP1123 FP,GRADE 3 EWS UI 3U DOOR,C/W LOOM & MIC,BLACK

A black 3U 19" rack mounting door complete with a Grade 3 user interface and PA microphone ready for connection to a T-Gen60 or T-Gen120 mounted inside the cabinet. A 1.5m power loom and microphone extension loom are included, long enough to connect to the T-Gen2 mounted on the gear plate in a 40U deep cabinet, for example. Suitable for mounting in a Simplex 4100ESi fire alarm panel.

FP1124 FP,GRADE 2 EWS UI 3U DOOR,C/W LOOM & MIC,GREY

The grey 3U 19" rack mounting door complete with the 4 Zone Grade 2 User Interface and PA microphone. A 1.5m power loom and microphone extension lead are included to allow connection to a T-Gen2 mounted in the back of the cabinet. Can be used as a spare part for the User Interface in FP1129, or for adding to a T-Gen2 in a rack cabinet.

FP1126 FP,GRADE 2 16Z EWS EXTENDER,3U 19" DOOR,GREY

A grey 3U 19" rack mounting door complete with a 16 Zone Grade 2 User Interface – but only 8 zones fitted. Connects on to FP1124 to expand the capacity from 4 zones to 12 zones. Add an FP1128 8 Zone Expansion Module to expand to the full T-Gen2 capacity of 20 zones.

FP1128 FP,GRADE 2 8Z EXPANSION BRD,C/W LOOM & MTG

An 8 Zone Expansion Module for providing 8 zones of evacuation control and indication. Fits onto FP1126 to expand to 20 zones, or can be used as a replacement for the 8 Zone Module already fitted.

FP1129 15U GRADE 2 EWS

A 4 zone emergency warning system including one T-Gen 120, 14A PSU, 4 zone Grade 2 User Interface and one 100V Switching Module. Additional 100V Switching Modules (FP1117) or Slave T-Gen2 modules (FP1115 or FP1116) can be added to provide more 100V zone outputs. A 16 zone expansion User Interface 3U door can be added (FP1126), plus an additional 8 zones of display/control (FP1128) to provide the full 20 zones for manual control/ indication. A high level interface to Vigilant *MX1*, *MX4428*, *F3200* or Simplex 4100ESi FIPs can be added via a FP1143 kit. A suitable add-on expansion cabinet is FP1130.

FP1130 15U EWS EXPANSION CABINET

A 15U blank-door cabinet with the same gearplate as FP1129, but fitted with only a 14A PSU and 230V mains GPO. Up to 3 x T-Gen 60 or T-Gen 120, 10 x 100V Splitter or Switching Modules, or an additional PSU can be added to provide additional zone or power outputs. It needs to be mounted adjacent to the FP1129 cabinet.

FP1144 FP, 60W T-GEN2 BUILDING OWS, 8U TITANIA CAB

A complete Building Occupant Warning System (BOWS) including a T-Gen 60, 14A PSE, 3U 19" rack mounting door with a single zone Grade 3 User Interface and microphone mounted in a titania-coloured 8U cabinet. Space for an additional T-Gen 60 and batteries, 3 x 100V Switching or 100V Splitter modules is available.

FP1134 FP, 120W T-GEN2 BUILDING OWS, 15U CAB

A complete BOWS including a T-Gen 120, 14A PSE, 3U 19" rack mounting door with a single-zone Grade 3 User Interface and microphone, all mounted in a 15U Titania-coloured cabinet. Space for batteries, additional T-Gen 120, and up to 6 x 100V Switching or 100V Splitter modules is available.

FP1139, FP, PSE GEARPLATE MTG, 24V, 14A, SPARE

Replacement 14A PSE for the PSU in the T-Gen2. This can also be used as an expansion PSU for larger systems.

FP1143, FP, T-GEN2 HLI BOARD

High Level Link Interface module allows an adjacent Vigilant MX1, MX4428 or F3200 Fire Panel using RZDU or Simplex 4100ESi Fire Panel using internal 4100Comms to be connected to the T-Gen2 to transmit alarm information (up to 32 fire zones to trigger alarm, message playing or paging) and monitor the T-Gen2 fault status.

ME0290 Mech Assy, 1955-3, T-Gen/MVAC Dynamic Microphone

ME0490 Mech Assy, 1955-44, T-GEN50, Dynamic Microphone

A noise-cancelling dynamic microphone suitable for plugging onto the T-Gen2 to provide emergency PA or for field recording of the digitised speech message(s). ME0290 has a 1m coiled cord. ME0490 has a 1m extension to this coiled cord, suitable for internal routing in the cabinet, if required.

ME0292 Mech Assy, 1955-25, T-Gen Empty Box, Keyed 003

A 240W x 295H x 85D, cream wrinkle coloured, locked, metal box suitable for mounting the T-Gen2 (not included) inside.

SU0360 A 4488 4 Zone Paging Console: A 4 zone paging console with microphone and chime option that can be used with the SU0361 A 4489 Audio Switcher to achieve 4 area paging from remote locations. Up to two paging consoles can be connected to the SU0361 Audio Switch.

SU0361 A 4489 Audio Switcher: Used with the A 4428 4 zone paging console to provide relay outputs. Able to be mounted inside the BOWS cabinet.

13 SUPPLEMENTAL TERMS & LICENSED SOFTWARE

The T-Gen2 contains Licensed Software.

These Supplement Terms ("Supplemental Terms") are in addition to any Terms and Conditions of Sale ("Agreement") entered into between the End-user ("You") of the 100V Switching Module ("Product") and Johnson Controls ("Johnson Controls") regarding your purchase of the Product and use of the Licensed Software (as defined below). To the extent of any conflict between the terms of the Agreement and any Supplemental Terms, the Supplemental Terms will apply. Your acceptance of the Product will constitute acceptance of these Supplemental Terms.

Title and Copyright. It is hereby understood and agreed that as between Johnson Controls and You, all information and intellectual property relating to the Product and Licensed Software including but not limited to patents, designs, drawings, instruction booklets, specifications, circuit drawings, componentry, trade secrets, trade marks and copyright in such information and intellectual property, and all right, title and interest therein, are the sole property of or licensed by Johnson Controls and You shall gain no right, title or interest in such information whatsoever. You do not acquire any rights to the Products except for the sole purpose for which the Product was supplied to You.

Licensed Software. The Product may contain incorporation of "Open Source" and other Third Party Software ("Licensed Software"). You must not, and must not permit any person reasonably within your control nor procure any person to reverse engineer, decompile, or disassemble the Licensed Software, and any attempt to do so shall be a breach of these Supplemental Terms and the Agreement except and only to the extent that such activity may be expressly permitted, notwithstanding this limitation, either by applicable law or, in the case of open source software, the applicable open source licence. You must not make any changes or modifications to any portion of the Licensed Software, or create any derivative works, without the written permission of an officer of Johnson Controls except as provided with respect to "open source" software. Any reverse engineering shall be at Your sole risk and Johnson Controls accepts no liability for any loss or damage howsoever incurred by You or any third party as a result of or arising out of any modifications made or any reverse engineering.

Portions of the Licensed Software may be subject to certain third party licence agreements governing the use, copying, modification, redistribution and warranty of those portions of the Licensed Software, including what is commonly known as "open source" software. Such portions of the Licensed Software are governed solely by the terms of such other licence, and no warranty is provided under the Agreement for open source software. By using the Licensed Software You are also agreeing to be bound to the terms of such third party licences. If provided for in the applicable third party licence, You may have a right to reverse engineer such software or receive source code for such software for use and distribution in any program that You create, so long as You in turn agree to be bound to the terms of the applicable third party licence, and Your programs are distributed under the terms of that licence. If applicable, a copy of such source code may be obtained by contacting your Johnson Controls representative.

Limitation of Liability. You acknowledge and agree that, to the extent permitted by law, Johnson Controls has no liability in contract, tort (including negligence or breach of statutory duty), by statute or otherwise for loss or damage (whether direct or indirect) of profits, opportunity, revenue, goodwill, bargain, production, contracts, business or anticipated savings, corruption or destruction of data or for any indirect, special or consequential loss or damage whatsoever except to the extent that such losses are caused by or contributed to by Johnson Controls' Wilful Misconduct or fraud, where "Wilful Misconduct" means any wilful or intentional breach, act or omission done by Johnson Controls with the intent to cause You material harm or where Johnson Controls was aware that material harm would result from such wilful or intentional breach, act or omission. Johnson Control's total liability under any contract and the Agreement shall not exceed the total dollar amount of the Products purchased by You from Johnson Controls.

Additional Copyright notices

Refer to the T-Gen2 Licences.txt file contained on the T-Gen2 USB drive when it is plugged into the PC for the purposes of updating the T-Gen2 configuration.

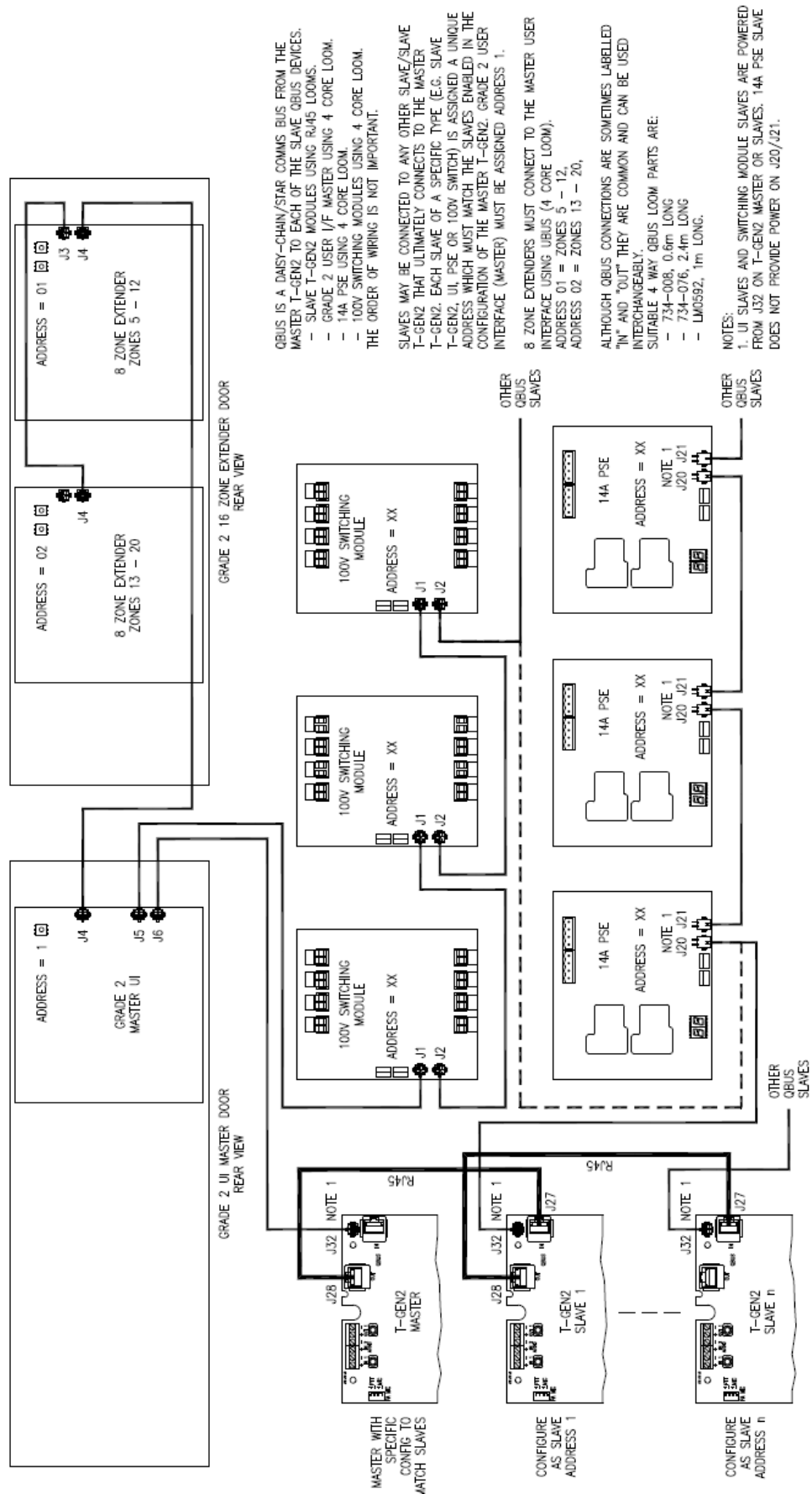

QBUS IS A DAISSY-CHAIN/STAR COMMIS BUS FROM THE MASTER T-GENZ TO EACH OF THE SLAVE QBUS DEVICES.

- SLAVE T-GENZ MODULES USING RJ45 LOOKS.
- GRADE 2 USER I/F MASTER USING 4 CORE LOOM.
- 14A PSE USING 4 CORE LOOM.
- 100V SWITCHING MODULES USING 4 CORE LOOM.

THE ORDER OF WIRING IS NOT IMPORTANT.

SLAVES MAY BE CONNECTED TO ANY OTHER SLAVE/SLAVE T-GENZ THAT ULTIMATELY CONNECTS TO THE MASTER T-GENZ. EACH SLAVE OF A SPECIFIC TYPE (E.G. SLAVE T-GENZ, UI PSE OR 100V SWITCH) IS ASSIGNED A UNIQUE ADDRESS WHICH MUST MATCH THE SLAVES ENABLED IN THE CONFIGURATION OF THE MASTER T-GENZ. GRADE 2 USER INTERFACE (MASTER) MUST BE ASSIGNED ADDRESS 1.

8 ZONE EXTENDERS MUST CONNECT TO THE MASTER USER INTERFACE USING UBUS (4 CORE LOOM).

ADDRESS 01 = ZONES 5 - 12,
ADDRESS 02 = ZONES 13 - 20,

ALTHOUGH QBUS CONNECTIONS ARE SOMETIMES LABELLED "IN" AND "OUT" THEY ARE COMMON AND CAN BE USED INTERCHANGEABLY.

SUITABLE 4 WAY QBUS LOOM PARTS ARE:

- 734-008, 0.6m LONG
- 734-076, 2.4m LONG
- LM0592, 1m LONG.

NOTES:

1. UI SLAVES AND SWITCHING MODULE SLAVES ARE POWERED FROM J32 ON T-GENZ MASTER OR SLAVES. 14A PSE SLAVE DOES NOT PROVIDE POWER ON J20/J21.

QBus Connection Wiring Diagram 1956-38

This page is intentional blank