

USING T-Gen2 IN 4100 Series Panels

This bulletin describes using the T-Gen2 Grade 3 Evacuation Warning System in 4100ESi, 4100ES, 4100U, 4100S1 and older legacy 4100+/A panels.

General

The newly released T-Gen2 product range is described in Product Bulletin PBG0203 and the 100V Splitter Board is in PBG0205. A complete Building Occupant Warning Systems (BOWS) is described in PBG0206.

The various 4100ESi panels - 15U, 28U and 40U, support various arrangements of the T-Gen2 products.

In each example it is assumed one of the APS (or SPS) NAC outputs configured for Alarm Devices is wired to the non-latching Alarm input of the master T-Gen2 to automatically control the EWS from the Alarm Devices function on the 4100ESi.

Details for using the T-Gen2 in the earlier 4100ES, 4100U, 4100+ and 4100A panels are also covered in this bulletin.

15U 4100ESi

The 15U Compact 4100ESi Panel (FP1045) supports a single T-Gen 60 on the right hand side fold of the gearplate. A T-Gen 120 will not fit as it's too deep.

Additionally, one FP1117 100V Switching Module or one FP1118 100V Splitter Module may be mounted on the bottom RHS of the gearplate, to the right of the LPS power supply. Figure 1 shows this mounting.

This allows the system to support 4 floors or areas >2000m².

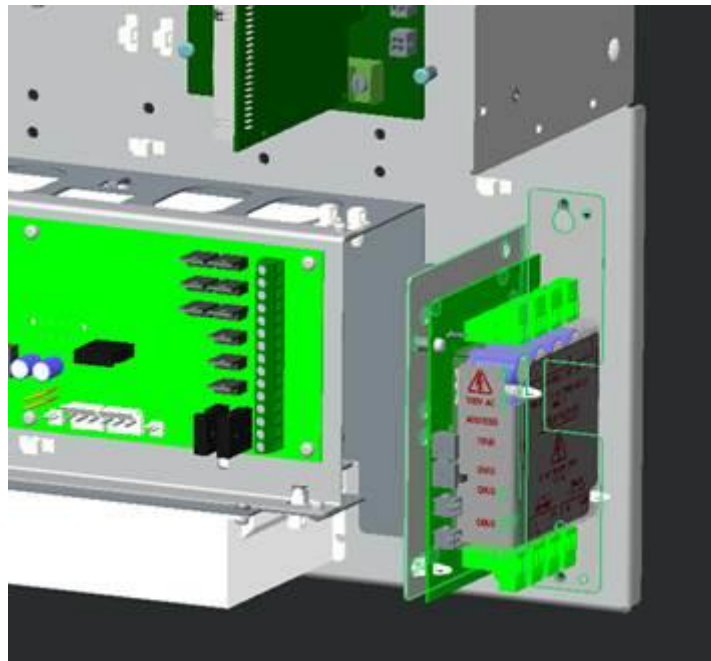

Figure 1 100V Switching/Splitter Module mounting on 15U Gearplate

To add a PA/Speech microphone, either the 4100-ME0512K (WA/Cube) or 4100-ME0513K (Centaur II) brigade kit could be fitted to the 7U display door. Both of these include a position to fit an ME0490 microphone (not included), that has a 1m cable that can be run to the T-Gen2 mounted in the cabinet.



Figure 2 4100-ME0513K Brigade Kit with ME0490 Microphone

For extra T-Gen2 equipment the following could be mounted alongside/underneath the 15U cabinet:

- An 8U windowed door expansion cabinet (4100-FP1046). This has space for:
 - One T-Gen 60 mounted on the FP1119 bracket.
 - The Brigade kit (4100-ME0512K or ME0513K) mounted on the 7U display door.
 - A T-Gen 120 mounted on the FP1119 bracket and one or two 100V Switching/Splitter Modules on the FP1120 bracket, if there is nothing mounted on the 7U display door immediately in front of where these T-Gen2 parts are fitted.
- An 8U blank door expansion cabinet (4100-FP1086). This has space for (see Figure 3):
 - Up to six FP1120 100V Switching/Splitter mounting brackets for mounting 100V Switching Modules or 100V Splitter Modules.
 - One FP1119 T-Gen2 mounting bracket for mounting one T-Gen 60 or T-Gen 120 unit.
 - An extra ME0504 APS 10A PSU.

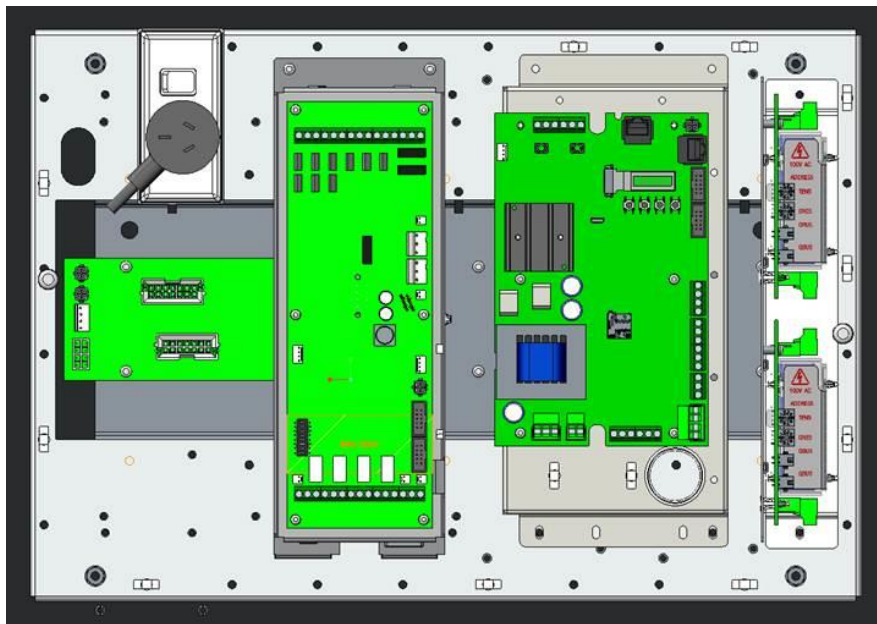

Figure 3 8U Expansion Cabinet with APS, T-Gen 60, and Switching/Splitters

- A 15U expansion cabinet (4100-FP1088 or 4100-FP1087) has space for one T-Gen 60 on the RHS fold of the gearplate and one 100V Switching Module/Splitter Module on the bottom RHS of the gearplate. Neither the FP1119 T-Gen2 mounting bracket, nor the FP1120 Switching/Splitter bracket can be added.

As the Compact 15U 4100ESi cabinet 19" rack is already full, adding a T-Gen2 User Interface (FP1123) is not possible without removing the 7U display door. Therefore, if a T-Gen2 with User Interface is needed for a 15U Compact 4100ESi, then using a separate BOWS cabinet (FP1136 or FP1137) is recommended. Other options are to use a 4100ESi 8U windowed cabinet (4100-FP1046) or a 15U

windowed expansion cabinet (4100-FP1088), and remove one of the 7U display doors and replace it with the FP1123 T-Gen2 User Interface and a 4U blank panel.

The T-Gen2 units will need to be powered from the LPS (or APS) VAUX outputs.

One VAUX output (2A) will power one T-Gen 60 with 40W output and no strobe current.

Two VAUX terminals (4A) will power one fully loaded T-Gen 60 with 1A strobe current.

Three VAUX terminals (6 A) will power (refer to Figure 4):

- One fully loaded T-Gen 60 (60W @ 100V plus 2A strobes).
- Two T-Gen 60 at 60W each (no Strobe load).
- One T-Gen 120 @ 120W (no Strobe load).

Two T-Gen 60 or one T-Gen 120 with decreasing power output as the strobe current is increased from 0A.

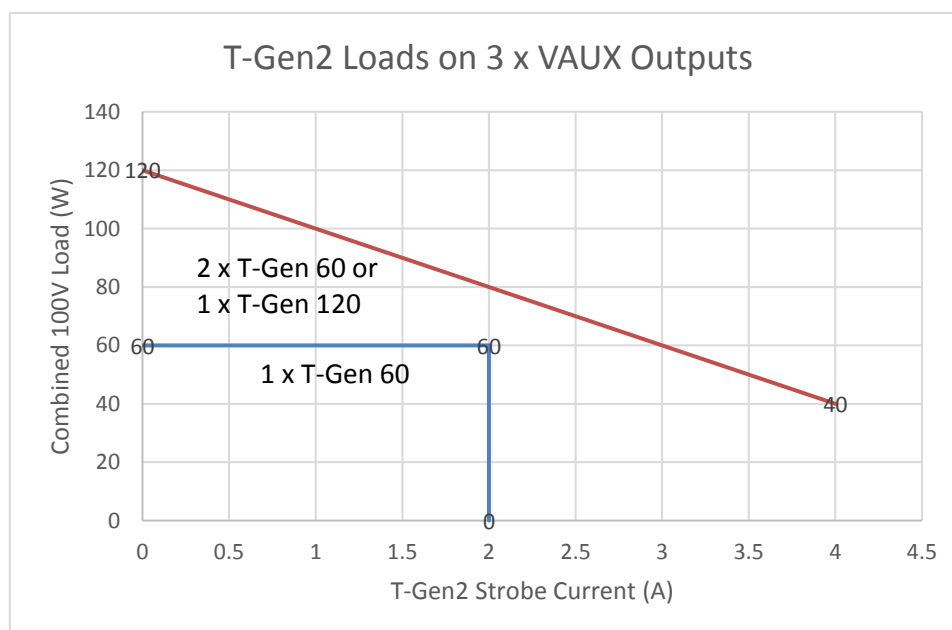

Figure 4 Supported T-Gen2 Loads on 3 x VAUX Outputs

Note: It is assumed the rest of the 4100ESi current consumption is less than 4A in the above examples.

28U/40U BTO 4100ESi

The 28U/40U 4100ESi cabinets support a range of T-Gen2 equipment.

Each PDI expansion bay can support (at the same time) -Refer Figure 5:

- Two FP1119 PDI T-Gen2 mounting brackets with a T-Gen 60 or T-Gen 120 on each.
- One FP1120 100V Switching/Splitter mounting bracket with 2 100V Switching Modules or 100V Splitter Modules.
- One APS Power Supply to provide power.

Other combinations are possible.

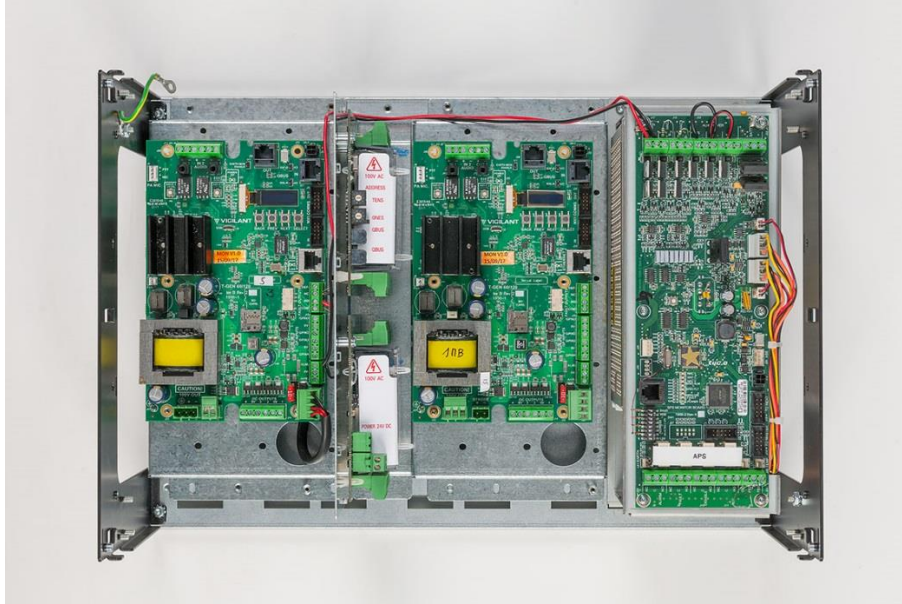

Figure 5 PDI Expansion Bay with 2 x T-Gen2, 1 x FP1120 and APS

The APS provides Signal Power directly to the PDI backplane, which is used to power each T-Gen2 via the plug-in loom provided with FP1119. Alternatively signal power can be obtained from an APS in an adjacent bay by using the 734-301 loom to link the two bays.

Additional PDI expansion bays can be provided for additional equipment.

The 19" rack can accommodate the FP1123 T-Gen2 User Interface (black), which provides a Grade 3 User Interface for controlling the T-Gen2 and a microphone for making paging or emergency speech announcements. It is connected to the master T-Gen2 via the 4-way and microphone cables included.

If just the PA microphone is needed, then either of the 4100-ME0512K or 4100-ME0513K brigade kits can be used in a 7U door, or the FP0935 / FP0937 4U Brigade Door be fitted to the 19" rack, all with the ME0490 microphone wired to the master T-Gen2.

Power Supply Requirements

AS 1670.1:2015 requires that the PSU must be able to supply the full alarm load of the panel and any connected EWS without depending on any standby batteries.

Therefore, it is necessary to do a design check to make sure the 4100ESi is able to power the 4100ESi and T-Gen2 in alarm, without exceeding the PSU rating.

As the T-Gen2 can draw 3A @ 60W load, 6A @ 120W load, plus the connected strobe load of up to 2A, the total load on the T-Gen2 may need to be less than the maximum.

Figure 6 shows the connectable 100V load on various T-Gen2 combinations when powered from the APS Signal Power, taking into account the T-Gen2 strobe current ranging from 0 to 4A.

Basically each APS can support:

- One or two T-Gen 60 units at full load (60W on 100V) plus 2A Strobe current each.
- One T-Gen 120 at full load (120W) plus 2A Strobe current.
- Two T-Gen 120 units with a combined 100V load of 200W with no strobe current, decreasing to a combined 120W output as up to 4A of strobe current is allowed for.

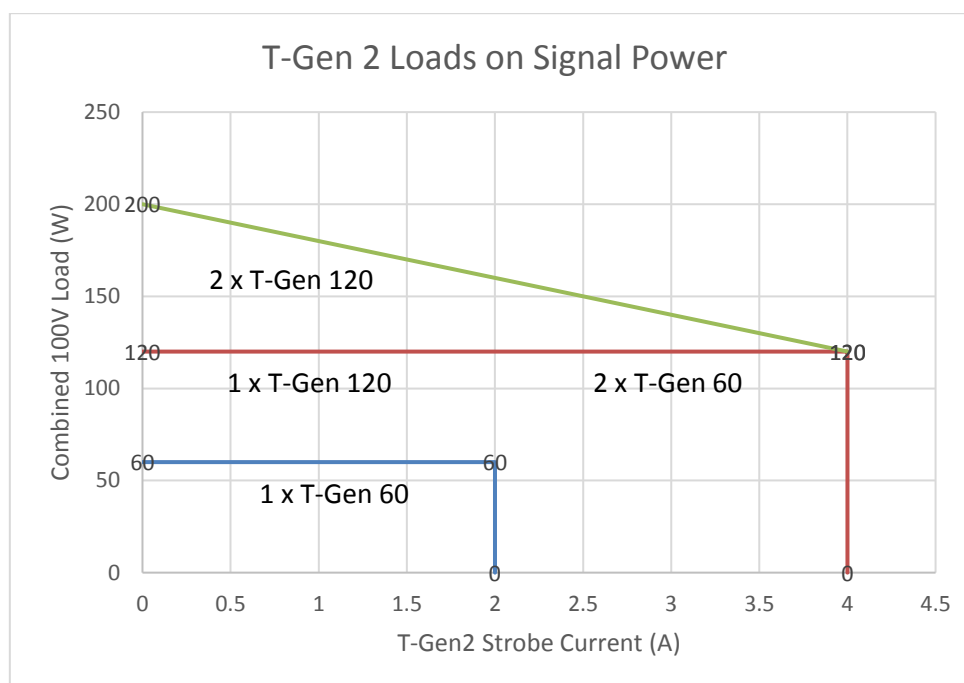

Figure 6 Supported T-Gen2 Load on Signal Power

Note: Each APS is limited to 10A output in total (including other loads). If additional system loads must be supported, an additional APS bay, etc., may be needed.

Alternative Connection of Strobes

If old-style Xenon Strobes are being used it is recommended to connect these directly to a NAC output on the APS/LPS. This has the advantages of reducing the load on the VAUX outputs (but not the APS itself), and the NAC outputs are better suited to supplying the high currents surges these strobes can require. However, it could have a disadvantage in that the T-Gen2 is not controlling the Strobes, so a manual activation of Evac via the T-Gen2 User Interface) will not activate the Strobes. A manual activation via the 4100ESi panel will drive the strobes as well as the T-Gen2.

4100ES

The 4100ES uses the same bays as the 4100ESi, so the FP1119 and FP1120 mounting brackets for T-Gen2 and 100V Switching/Splitter Modules can be fitted.

The SPS power supply normally used in 4100ES is not sufficient to power the T-Gen2s to full power (but can be used - see later in the bulletin).

Therefore, it is recommended that an ME0470 5A PSU mounted in the same bay as the T-Gen2s be used to power the T-Gens. Figure 7 shows a bay with:

- Two FP1119 PDI T-Gen2 mounting brackets with a T-Gen 60 or a T-Gen 120 on each.
- One FP1120 100V Switching/Splitter mounting bracket with two 100V Switching or Splitter Modules.
- One ME0470 5A PSU.

The arrangement shown is the only combination that allows all four of these modules to be mounted simultaneously, but other combinations are possible.

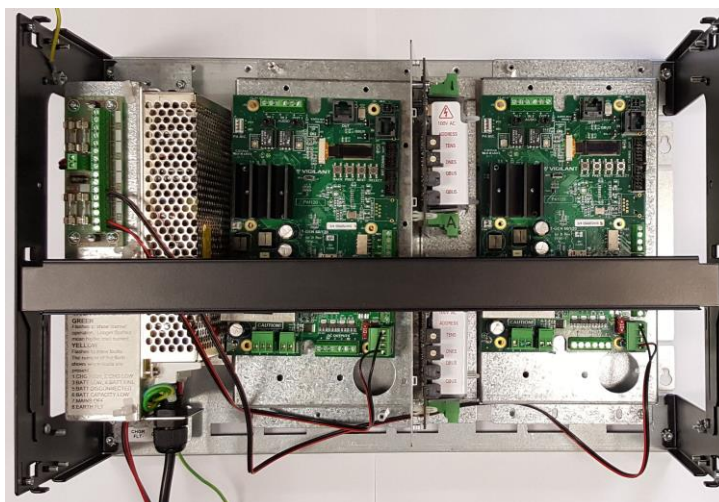

Figure 7 PDI Bay with 2 x T-Gens, Splitter & 5A PSU

The 5A PSU provides power for the T-Gens and other modules, but the 5A output is not sufficient to power a full complement of T-Gen2s and loads.

The 5A PSU can power:

- Two T-Gen 60 modules with a combined 100V load of 100W, with no strobe load, or
- One T-Gen 120 module with up to 100W of 100V load with no strobe load.

In both arrangements the 100V output power must be reduced as the strobe load current is increased. Therefore, it is recommended that strobes be powered from an unused NAC output (see [Alternative Connection of Strobes](#) earlier). This leaves all the 5A PSU capacity for audio loads.

Figure 8 shows the loads that the 5A PSU can support.

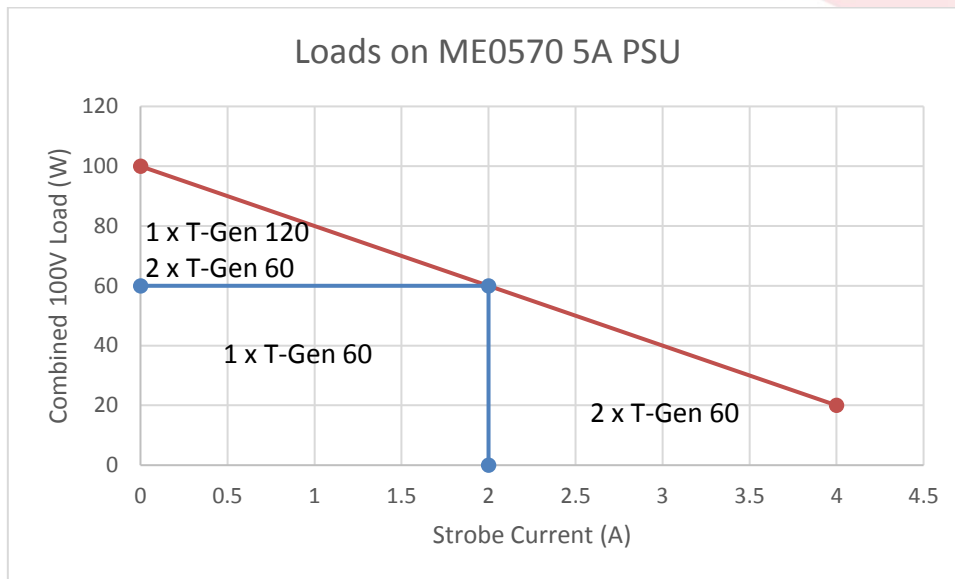

Figure 8 Supported T-Gen2 Loads on 5A ME0470

The 24V power supply for the T-Gen2s must be wired directly from the +24V screw terminals on the ME0470 PSU Fuse Board to each T-Gen2 (not via the PDI backplane). Each T-Gen2 must be connected to a separate output, with a 3A fuse used on the Fuse Board for T-Gen 60 and a 5A fuse for T-Gen 120.

If using the LM0632 loom included with each FP1119 bracket, cut off the white PDI connector and connect the two red wires to the same 24V terminal on the Fuse Board and the two black wires to 0V.

An SPS NAC output programmed for the warning system (usually NAC 3) should be used to control the master T-Gen2 Alarm Input as shown in Figure 10.

The 0V terminal of the 5A PSU must be connected to 0V of the SPS (so the NAC output works with the T-Gen2). This could be achieved by using a single battery, with both battery -ve leads joined together.

4100ES-S1 Panels

The 4100ES-S1 panel has an SPS and CPU in the top bay, and, by default, nothing mounted in the second bay.

The SPS could be used to power 1 x T-Gen60 but with limited load capacity (see Using the SPS to Power T-Gen2). Therefore it is recommended that an additional ME0470 5A PSU be included to power the T-Gen2s, and that this is mounted in the second bay using the same arrangement and maximum loads described for a 4100ES PDI bay earlier.

Using the SPS to Power T-Gen2

The SPS NAC output can be programmed to be a normally energized 2A output. The SPS also provides a 2A AUX output. These can be used to power a T-Gen 60 with up to 40W of 100V load (no strobes). Figure 9 shows the T-Gen2 loads that can be supported by a T-Gen 60 powered from the NAC/AUX output. As the 100V load must be decreased for any Strobe current, it is recommended that any strobes be powered from a separate NAC output (see Alternative Connection of Strobes earlier).

Note, the SPS outputs will shut down if the current exceeds 2A, so do not load to higher than that shown in Figure 9).

Another SPS NAC output programmed as Warning System (e.g., NAC 3) should be used to control the T-Gen2 Alarm input, wired as per Figure 10. This also shows the NAC wiring to the T-Gen2 power supply terminals.

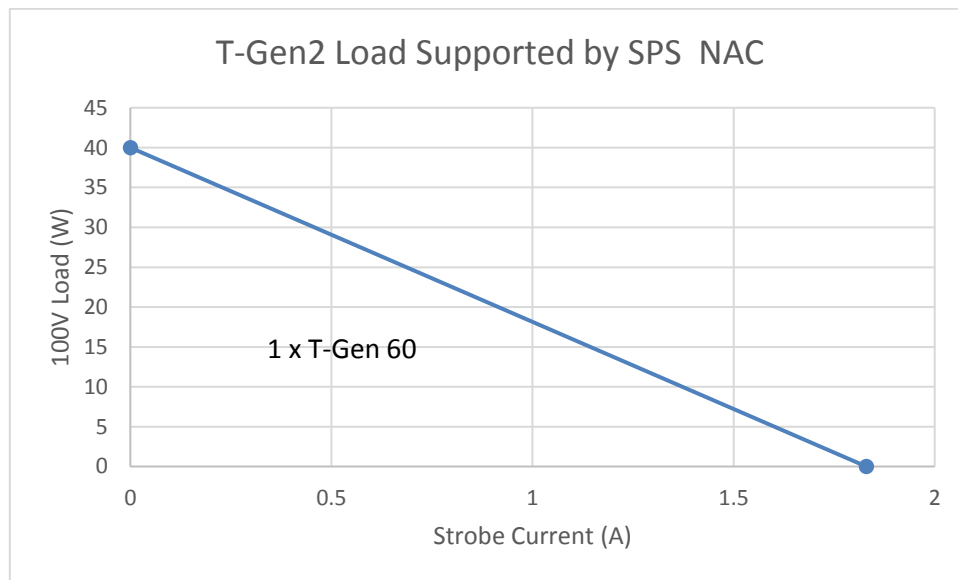

Figure 9 T-Gen2 Load Supported by SPS NAC/AUX Output

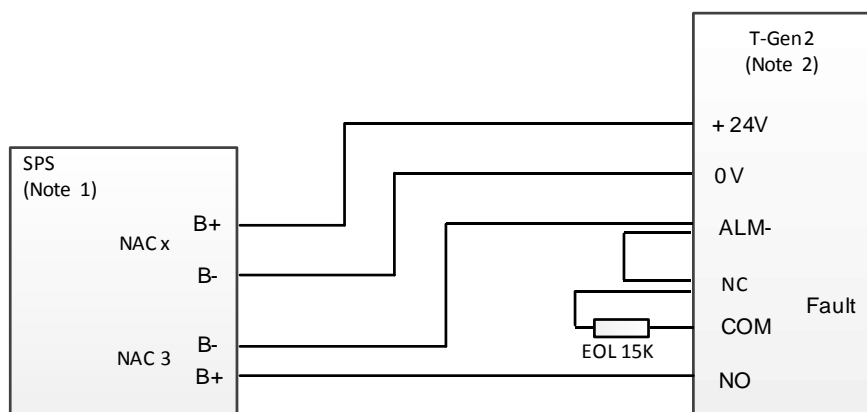

Figure 10 SPS to T-Gen2 Wiring

Notes

1. NAC x programmed as normally energized 24V output. NAC 3 programmed as Warning System.
2. The T-Gen2 needs to be configured for 4100ESi mode, so that the ALM input is unsupervised on the T-Gen2.
3. The NAC x / AUX wiring is required only when powering the T-Gen2 from the SPS.

4100U 4100+ and 4100A Panels

Mounting

The T-Gen60 can be used in a 4100U, 4100A, 4100+ legacy bay by using a Legacy Board bay mounting kit 4100-ME0419.

For 4100U-S1 panels the same space restrictions apply as described earlier for the 4100ES-S1 panel.

The T-Gen60 will occupy 2.5 legacy slots. The T-Gen 120 cannot be used in these older panels due to power supply and mounting complications.

Power and Wiring

For 4100U and 4100U-S1 panels the T-Gen 60 can be powered either via the SPS (See Using SPS to Power T-Gen2) or by adding a 4100-ME0470 5A power supply as described for the 4100ES.

For older 4100+ and 4100A panels the T-Gen 60 can be powered from the 4100-0157AUK PSU and fuse board. The available power will need to be checked and 1 x fuse updated to 3A. Note only 4A is available in total from the PSU.

The T-Gen60 Alarm input can be wired from a 4100-4321 6 Supervised signal card (using same arrangement as a NAC). Alternatively a relay can be used to signal the alarm input and a separate device like a MAPNETII IAM used to monitor the T-Gen2 fault output.

Optionally a 4100-ME0470 PSU can be used. In some cases these may already be installed for a T-GEN 50 or older tone generator. Note that if a Vigilant 1948 PSU has been used it is rated at 2A which will provide power for only 40W of audio.