

## T-GEN2 GRADE 3 BUILDING OCCUPANT WARNING SYSTEM

*The VIGILANT T-Gen2 Emergency Warning System is available as two complete Grade 3 Building Occupant Warning Systems (BOWS) – 8U @ 60W and 15U @ 120W. New versions approved to AS 4428.16 replace the earlier models.*

The VIGILANT T-Gen2 Building Occupant Warning System (BOWS) is a self-contained AS 4428.16 Alert and Evacuate tone generator, with integral power supply, digitised speech messages, and PA microphone. It has been designed to connect directly to a fire alarm panel, and can also be used as a stand-alone unit.

The BOWS units contain a T-Gen2 Grade 3 User Interface, speech microphone, T-Gen2 and PSU, with space for additional modules and batteries.

Non-emergency paging options, IP remote audio compatibility, and multiple audio inputs make the VIGILANT BOWS a versatile base unit for a variety of applications meeting the single zone requirements.

### FEATURES AND BENEFITS

- Self-contained Building Occupant Warning System (BOWS) suits multiple applications
- Available in 60W (8U) and 120W (15U) versions
- Compliant with AS 4428.16 for Grade 3 applications
- Emergency PA microphone, Alert/Evacuate/Speech controls
- Zone Paging options – up to 4 separately-selectable speaker areas
- 4-zone remote paging microphone/console option
- Auto/Manual operation
- Selectable priority for Paging/Remote/Background Audio inputs
- Alarm input and Fault output signals for fire panel connection
- Optional High Level Interface with Vigilant MX1, MX4428, F3200 or Simplex 4100ESi
- Programmable Alert to Evacuate delay (0-600sec or manual)
- Pre-recorded Alert and Evacuate messages, field re-recordable for flexibility
- Up to 2A Strobe output per T-Gen2
- Integral 14 Amp (peak) Power Supply with fault supervision
- Space for 2 x 17Ah (8U) or 2 x 40Ah (15U) batteries
- Space for 3 (8U), 6 (15U) x 100V Switching/Splitter Modules for short-circuit isolated outputs
- Space for an additional T-Gen 60 (8U) and T-Gen 120 (15U) for higher loads
- Expandable up to 9 synchronized Slaves T-Gens and 10 PSUs
- 8U 19" rack cabinet: 440mm H x 550mm W x 210mm D (60W)
- 15U 19" rack cabinet: 750mm H x 550mm W x 210mm D (120W)

8U

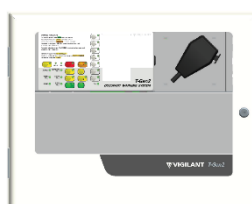

15U



## GENERAL DESCRIPTION

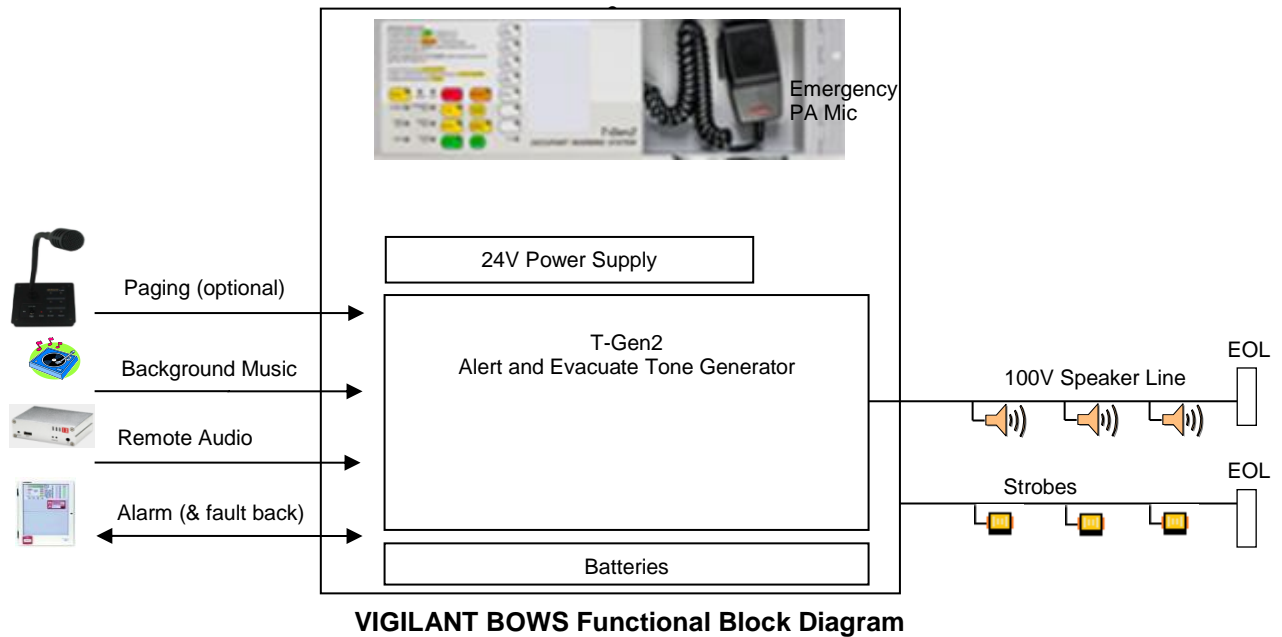

The VIGILANT BOWS has a microphone for emergency public address, fault and status indicators, and manual controls to control its operation. It has audio inputs for background music, remote non-emergency audio (which can be used when streaming audio over IP networks), or non-emergency paging (zone-selective with an add-on option). Also included is a 14A power supply.

It is available in an 8U cabinet (FP1144) and in a 15U cabinet (FP1134).

## EXPANSION OF BOWS UNITS

The FP1144 8U cabinet BOWS may be upgraded in the field by adding a second T-Gen 60 (FP1115) to provide a second 100V line output. It also has space for 3 x 100V Switching Modules (FP1117) for area paging outputs and short-circuit isolation or 100V Splitter Modules (FP1118) to provide short-circuit isolated outputs only.

With two T-Gen 60s fitted in the 8U FP1144, the PSU and the available battery capacity (17Ahr) can support 60W of 100V audio load on each T-Gen 60, plus a combined 1.5A of strobe load.

The FP1134 15U cabinet is fitted with one T-Gen 120 and can be expanded with an additional T-Gen 60 (FP1115) or T-Gen 120 (FP1116) to provide additional power output. It also has space for 6 x 100V Switching Modules (FP1117) for area paging outputs and short-circuit isolation or 100V Splitter Modules (FP1118) to provide short-circuit isolated outputs only.

With two T-Gen 120s the FP1134 14A PSU can support up to 120W load, with no strobe load on each T-Gen 120, decreasing to a combined 160W load with a total strobe current of 4A.

Further expansion can be achieved using the FP1130 15U expansion cabinet, allowing additional T-Gen2 (60 or 120W), PSUs and Switching / Splitter Modules to be housed adjacent to the BOWS unit. Up to 9 slave T-Gen2 and 10 PSUs in total can be connected to the Master T-Gen2.

### CONNECTING TO FIRE ALARM PANEL

*Basic wiring method:*

The BOWS has an Alarm input (ALM-) which is normally terminated with an EOL resistor and shorted by the fire alarm panel to activate the Alert / Evacuation tones.

The BOWS has a common Fault output (DEF-) which is normally open-circuit and pulled to 0V on fault. Voltage-free fault relay contacts (NO, NC, COM) are also provided. One of these is usually wired to the alarm system to indicate a fault condition.

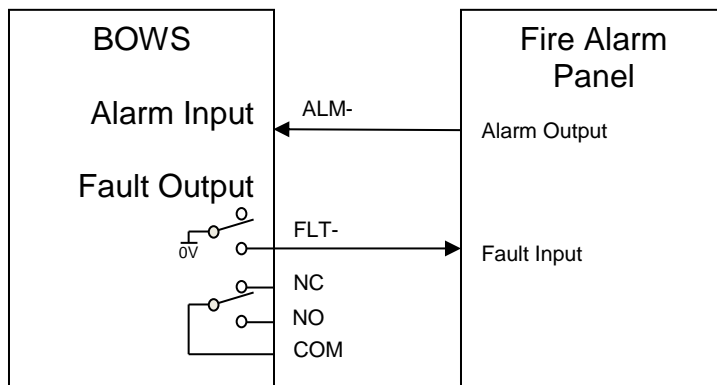

*High Level Link:*

Two wiring options are available:

- 1) Direct connection MX1 to T-Gen2 using a 10-way ribbon cable:  
 This option can be used only when the T-Gen2 and MX1 are mounted in the same cabinet or in a dual cabinet installation, both adjacent to each other. Connections to external RZDU devices is not possible and Port 0 on the MX1 must not be used for any other function.
  
- 2) HLI board (Optional module FP1143) is a logical Interface between T-Gen2 and the RZDU network. This connection method allows one or more external / remote RZDU devices to be used.  
 The HLI board (module) includes a separate short-circuit isolated RZDU connection for wiring to remote RZDU devices – so that a short circuit in the field wiring does not affect the T-Gen2’s communication with the fire panel. Up to 32 Zones Alarm states and other triggers can be sent to the T-Gen2 to manage alarms and play of messages, while the T-Gen2 can return the fault state.

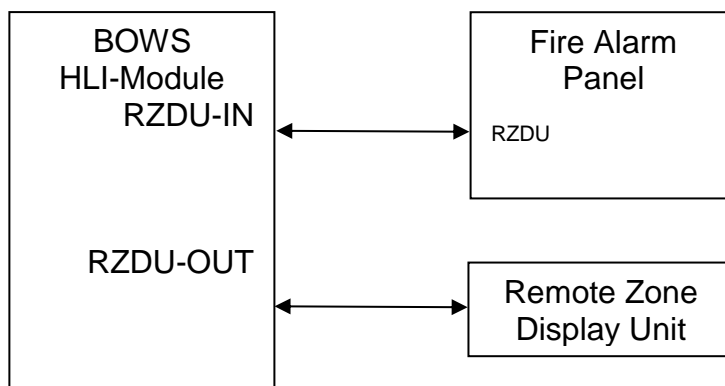

The HLI module can also be used with Simplex 4100ESi panels. The T-Gen2 connects onto the internal 4100Comms bus and appears to the 4100ESi as a slave device with a number of programmable input and output devices.

### AUDIO INPUTS

The BOWS has two general purpose line-level (150mV) audio inputs. These can be configured for different operating modes: “Always On / Music”, “Paging Line” to be used with a Paging Console, and “GP / HLL Input” to be enabled when a specific GP input is active.

These audio inputs could be used for:

#### Background Music



The audio input is usually configured as “Always On”, and a music source connected. A volume control is provided to adjust the output level. Screw terminals and a 3.5mm audio socket are provided for connecting the background music source to the BOWS.

#### Remote Audio



This mode can be used for connecting to external tone/message generators, specialist paging systems (e.g., PABX), or voice-over-IP (VoIP) modules (illustrated). A separate digital input is used to enable the audio input. A volume control is provided to adjust the output level. The priority of the audio input (relative to the emergency PA microphone and the zone paging), and whether the remote audio is to override the Alert/Evacuation tones is configurable. (Note that this would be non-compliant to AS4428.16)

### ZONE-SELECTABLE PAGING (Two Options)

The BOWS can optionally be fitted with 100V Switching Modules (FP1117) which splits the single 100V output into four separately selectable 100V line outputs. Each of the 4 outputs has separate line supervision (o/c & s/c) and the 100V Switching Module will isolate a shorted output allowing the other outputs to operate. Each output can handle up to 100W maximum load, but the total load cannot exceed the T-Gen2 rating (or maximum 120W per Switching Module in total).

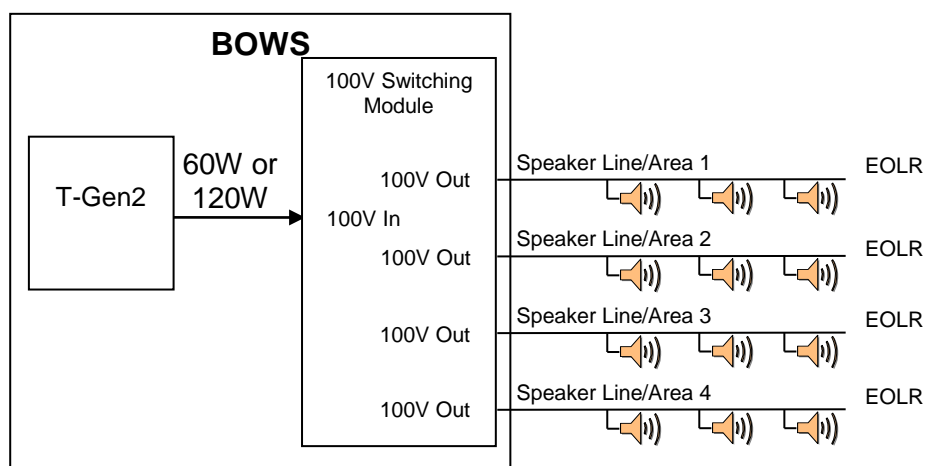

**BOWS fitted with a 4-way 100V Switching Module**

The 100V Switching Modules allow the T-Gen2 to control which outputs receive the 100V audio signal from the T-Gen2 – making area-specific paging options possible. Two options for area paging are available (can be combined).

## 1 USING GRADE 3 USER INTERFACE

The Grade 3 User Interface has 4 Area PA/Paging pushbuttons that when pressed will direct the voice announcements from the front panel microphone to specific areas. Each output of the 100V Switching Modules can be configured to belong to a specific area, no area, or all areas. This allows various paging arrangements to be constructed.

## 2 USING AN EXTERNAL PAGING CONSOLE

Up to two external 4-zone paging consoles (SU0360) can be combined with an SU0361 Audio Switcher to create remote paging units for the T-Gen2 BOWS. The SU0361 Audio Switcher is mounted in the BOWS and wired to 4 GP Inputs to indicate when each area is active. The Paging Consoles are located where needed and connect to the Audio Switcher using RJ45 cable.



**SU0360 Paging Microphone**



**SU0361 Audio Switcher**

Both paging solutions offer a pre-announcement chime which can play a chime signal when the microphone PTT is activated.

The priority of the paging function compared to the other audio inputs, user functions and emergency functions is configurable.

## IP NETWORKING

The BOWS supports streaming audio over IP Networks using the BARIX range of Audio-over-IP modules. There are many possible configurations that can be used, depending on the application (see LT0561 for more details).

One typical application is to use the BARIX modules to allow a master BOWS to make paging announcements to multiple slave BOWS units connected together on a LAN. For this application, an Annunicom 200 may be used in the master BOWS and either an Annunicom 200 or Exstreamer 100 at each slave BOWS.

When the paging microphone is activated, this is signalled to each slave unit, which in turn receives streaming audio from the master and broadcasts it over the loudspeakers.

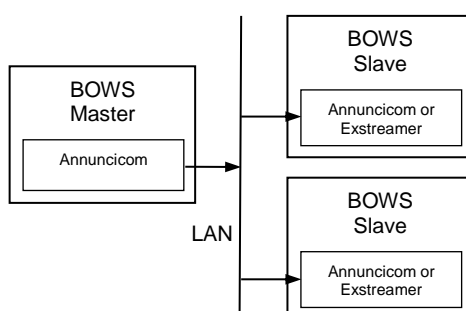

The Barix PS16 Paging Console may also be used to broadcast messages over a LAN to one or more BOWS. The console has 16 buttons which can be configured to select individual BOWS units for paging.

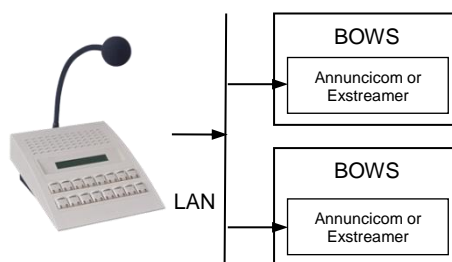

## CONFIGURATION

The BOWS units come pre-configured with the BOWS\_AS4428 configuration. This enables basic operation on the User Interface, an alarm input, Audio 1 as Always ON and Audio 2 activated by GP1 input.

The BOWS\_AS2220 configuration can be selected from the T-Gen2 OLED display and buttons to use AS2220 style tones (not AS4428.16 ones).

Any other configuration – e.g., enable area paging using a Switching Module, Slave T-Gen2, or assign speech, input functions or change the User Interface operation will require a configuration to be prepared and downloaded using the Windows SmartConfig application.

## FURTHER INFORMATION

Details on the various T-Gen2 modules can be found in the latest issue of product bulletin PBG0203.

## SALES DRAWINGS

- 1986-36** FP1134, FP, 120W T-Gen2 BUILDING OWS, 15U CAB
- 1986-37** FP1144, FP, 60W T-Gen2 BUILDING OWS, 8U TITANIA CAB
- 1956-19** FP1116, FP, T-Gen 120, 24V, C/W INSTALL LIT & MTG
- 1956-21** FP1117, FP, 100V SWITCHING MODULE, C/W LIT, LOOMS & MTG BRK
- 1956-22** FP1118, FP, 100V SPLITTER MODULE, C/W LIT, LOOMS & MTG BRKT
- 1992-16** FP1122, FP, GRADE 3 EWS UI 3U DOOR, C/W LOOM & MIC, GREY
- 1956-17** FP1143, FP, T-GEN2 HLI BOARD

## ORDERING CODES

### **FP1144 FP, 60W T-Gen2 BUILDING OWS, 8U TITANIA CAB**

A complete Building Occupant Warning System (BOWS) including a T-Gen 60, 14A PSU, 3U 19" rack mounting door with Grade 3 User Interface and microphone mounted in a titania-coloured 8U cabinet. Space for an additional T-Gen 60, batteries, and 3 x 100V Switching or 100V Splitter modules is available. The optional FP1143 (HLI) can be fitted for linking to a compatible fire panel.

**FP1134 FP, 120W T-Gen2 BUILDING OWS, 15U CAB**

A complete BOWS including a T-Gen 120, 14A PSU, 3U 19" rack mounting door with Grade 3 User Interface and microphone, all mounted in a 15U x 200 deep rack cabinet. Space for an additional T-Gen 120, batteries, and up to 6 x 100V Switching or 100V Splitter modules is available. The optional FP1143 (HLI) can be fitted for linking to a compatible fire panel.

**FP1130 FP, T-Gen2 EXP CAB, C/W 14A PSU, 15U, BLANK DR**

A 15U x 200 deep 19" cabinet to be installed adjacent to the BOWS to allow further expansion to be made. Includes a 14A Power Supply, to mount 2 x 120W T-Gen2s and 6 Switching or Splitter Modules a gearplate and up to 40Ahr of batteries to give maximum flexibility to the system. The cabinet has a blank outer door.

**FP1115, FP, T-Gen 60, 24V, C/W INSTALL LIT & MTG**

T-Gen 60 model of T-Gen2 able to drive a speaker load up to 60W. Supports two non-emergency audio inputs (BGM, paging), a microphone audio input (Speech or Paging), 6 supervised inputs (Alarm, Fault, Paging), 4 open-collector outputs, normally-energised Fault relay, supervised single polarity strobe output, and 100V speaker output. Able to fit to FP1144 as a spare part or Slave T-Gen2.

**FP1116, FP, T-Gen 120, 24V, C/W INSTALL LIT & MTG**

T-Gen 120 model of T-Gen2 able to drive a speaker load up to 120W. Able to fit to FP1134 as a spare part or Slave T-Gen2.

**FP1117 FP, 100V SWITCHING MODULE, C/W LIT, LOOMS & MTG BRK**

Provides 4 supervised, short-circuit isolated 100V outputs (each rated at up to 100W) from the T-Gen2's 100V output, along with control of each output by the T-Gen2 to provide area paging. A QBus slave module. Supplied on *MX1*-style mounting bracket with cables and EOLs.

**FP1118 FP, 100V SPLITTER MODULE, C/W LIT, LOOMS & MTG BRKT**

Provides 4 supervised, short-circuit isolated 100V outputs (each rated at up to 100W) from the T-Gen2's 100V output. No control of the outputs is available. Signals fault to the

T-Gen2 by superimposing a fault on the T-Gen2's 100V input. Standalone operation (not a QBus slave). Supplied on *MX1*-style mounting bracket with cables and EOLs.

**FP1122 FP, GRADE 3 EWS UI 3U DOOR, C/W LOOM & MIC, GREY**

A grey 3U 19" rack mounting door complete with a Grade 3 user interface and PA microphone ready for connection to a T-Gen 60 or T-Gen 120 mounted inside the cabinet. A 1.5m power loom and microphone extension loom are included. Suitable as a spare part for FP1144 and FP1134.

**FP1139, FP, PSE GEARPLATE MTG, 24V, 14A, SPARE**

Replacement or expansion 14A PSE for the BOWS.

**FP1143 FP, T-Gen2 HLI BOARD C/W LIT, LOOMS & MTG BRKT**

Provides a high-level link between the RZDU port of the Vigilant MX1, MX4428 and F3200 fire panels, or the internal 4100Comms port of a Simplex 4100ESi, and the T-Gen2. Supplied on an MX-style mounting bracket the same as Switching/Splitter Modules.

**SU0360 A 4488 4 Zone Paging Console**

A 4 zone paging console with microphone and chime option that can be used with the SU0361 A 4489 Audio Switcher to achieve 4 area paging from remote locations. Up to two paging consoles can be connected to the SU0361 Audio Switch.

**SU0361 A 4489 Audio Switcher**

Used with the A 4488 4 zone paging console to provide relay outputs. Able to be mounted inside the BOWS cabinet.

**Literature Items (available electronically)**

LT0667	T-Gen2 INSTALLATION GUIDE
LT0673	T-Gen2 Grade 3 USER INTERFACE OPERATOR MANUAL
LT0693	T-Gen2 Grade 3 BOWS INSTALLATION INSTRUCTIONS

**SPECIFICATIONS**

	<b>FP1144 (8U)</b>	<b>FP1134 (15U)</b>
<b>Weight</b>	17.5kg	26kg
<b>Size (WxHxD)</b>	550 x 440 x 210mm	550 x 750 x 210mm
<b>PSU Output Current (Peak)</b>	14A	14A
<b>DC Supply Voltage</b>	19.2Vmin - 28.8Vmax	19.2Vmin - 28.8Vmax
<b>Operating Temperature Range</b>	-5C to +45C	-5C to +45C
<b>Relative Humidity</b>	0 to 95% non-condensing	0 to 95% non-condensing
<b>Storage Temperature Range</b>	-20C to +70C	-20C to +70C
<b>Quiescent Current</b>		
Audio enabled but idle (no signal)	290mA	290mA
<b>Active Current - 27Vdc (excl. Strobe)</b>	3.1A @ 60W	6.1A @ 120W
<b>100V Output</b>		
Line Voltage - AC (Tones)	100Vrms	100Vrms
Line Power - Tones	60W	120W
- Audio	60W	120W
Maximum line capacitance	200nF	200nF
<b>Audio Frequency range</b>		
+/- 1dB	260Hz – 3800Hz	260Hz – 3800Hz
+/- 3dB	215Hz – 8400Hz	215Hz – 8400Hz
THD (Audio Input 1kHz)	< 0.25%	< 0.25%
SNR (Audio Input 1kHz)	> 75 dB(A)	> 75 dB(A)
<b>100V Speaker Line Supervision</b>		
ELD - 1 Branch	56k 0.4W	56k 0.4W
- 2 Branches	100k 0.4W	100k 0.4W
<b>Strobe Output</b>		
ELD - 1 to 3 branches	1x10k - 3 x 27k 0.4W	1x10k - 3 x 27k 0.4W
Current rating	Max 2.0A	Max 2.0A
<b>Audio Inputs</b>		
Audio 1 & Audio 2	230mVrms (min) into 5k $\Omega$ isolated for full power	230mVrms (min) into 5k $\Omega$ isolated for full power
Microphone - Input Level	3mVrms-100mVrms, PTT driven, supervised	3mVrms-100mVrms, PTT driven, supervised
<b>Digital Inputs</b>		
Alarm, AIE, GP1-4	2k7 EOL, <3.5V Active	2k7 EOL, <3.5V Active
<b>Open Collector O/Ps</b>		
OC1 & OC2	<1V @ 100mA, 30Vdc Optionally Load Supervised (fault <12V)	<1V @ 100mA, 30Vdc Optionally Load Supervised (fault <12V)
OC3 & OC4	<1V @ 100mA, 30Vdc	<1V @ 100mA, 30Vdc
<b>Interfaces</b>		
OLED, 4 button menu structured	For operation and configuration	For operation and configuration
QBus compliant	Master / Slave operation, User Interface, 14A PSE and 100V Switching Module	Master / Slave operation, User Interface, 14A PSE and 100V Switching Module
Slave T-Gen2	RJ45 Cable-In Cabinet	RJ45 Cable-In Cabinet
On-board Storage	4Mbyte (configuration and audio files)	4Mbyte (configuration and audio files)
Micro-SD Card - max size	32GB FAT32 support (card not provided)	32GB FAT32 support (card not provided)
<b>Headphone Output (internal) - Load impedance</b>	8 $\Omega$ min 6mW	8 $\Omega$ min 6mW
<b>Audio Output Level</b>	1.30Vrms	1.30Vrms