

Introduction

The 4090-9007 IDNet Addressable Signal Individual Adapter Module (Signal IAM) is an IDNet-compatible peripheral that combines both Class A (Style Z) and Class B (Style Y) Notification Appliance Circuit (NAC) functionality into a single device. The Signal IAM supervises and operates 24-VDC NACs and 25-VRMS or 70.7-VRMS speakers. The Signal IAM does *not* support Fire Fighter Phones.

Powered from an IDNet-compatible (addressable loop) channel, the Signal IAM provides a supervised, addressable interface between conventional notification appliances and the host FACP (see pages 4 and 5). The Signal IAM requires a supervised power supply or compatible signal input for driving the externally connected NAC appliances.

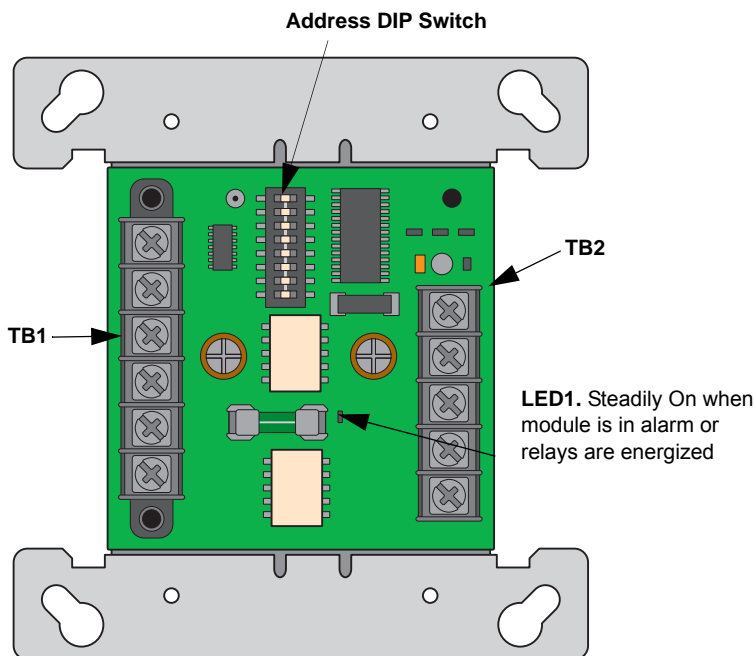

Figure 1 The Signal IAM

Before you handle any equipment, read the warnings on the back page.

Signal IAM installation consists of three parts:

- Setting the Signal IAM's address
- Wiring
- Mounting

This publication contains instructions for all three installation parts.

Specifications	
General	
Operating Temperature	0 to 49 degrees C 32 to 120 degrees F
Operating Humidity	Up to 93% relative humidity (non condensing)
Mounting	
Dimensions	Width = 4.13 in (10.5 cm) Height = 4 in (10.2 cm) Depth = 1.38 in (3.5 cm)
Back Box	4 in (10.2 cm) square box
Addressable Loop Power	
Nominal Terminal Input	35 VDC
Unit Load	
Device consumes 2 device loads on the addressable loop.	

In this Document

IAM Address Setting	2
Wiring	3
Mounting	6

IDNet Signal IAM Installation Instructions

IAM Address Setting

Each Signal IAM has a unique address. This address is associated with a custom label which identifies its physical location within a building.

The Signal IAM address is set via an eight-position DIP switch (Figure 1), with Position 1 being the least

significant bit (LSB) and Position 8 being the most significant bit (MSB). Set the address as shown in Figure 2. Use a small screwdriver or pen to set the switches.

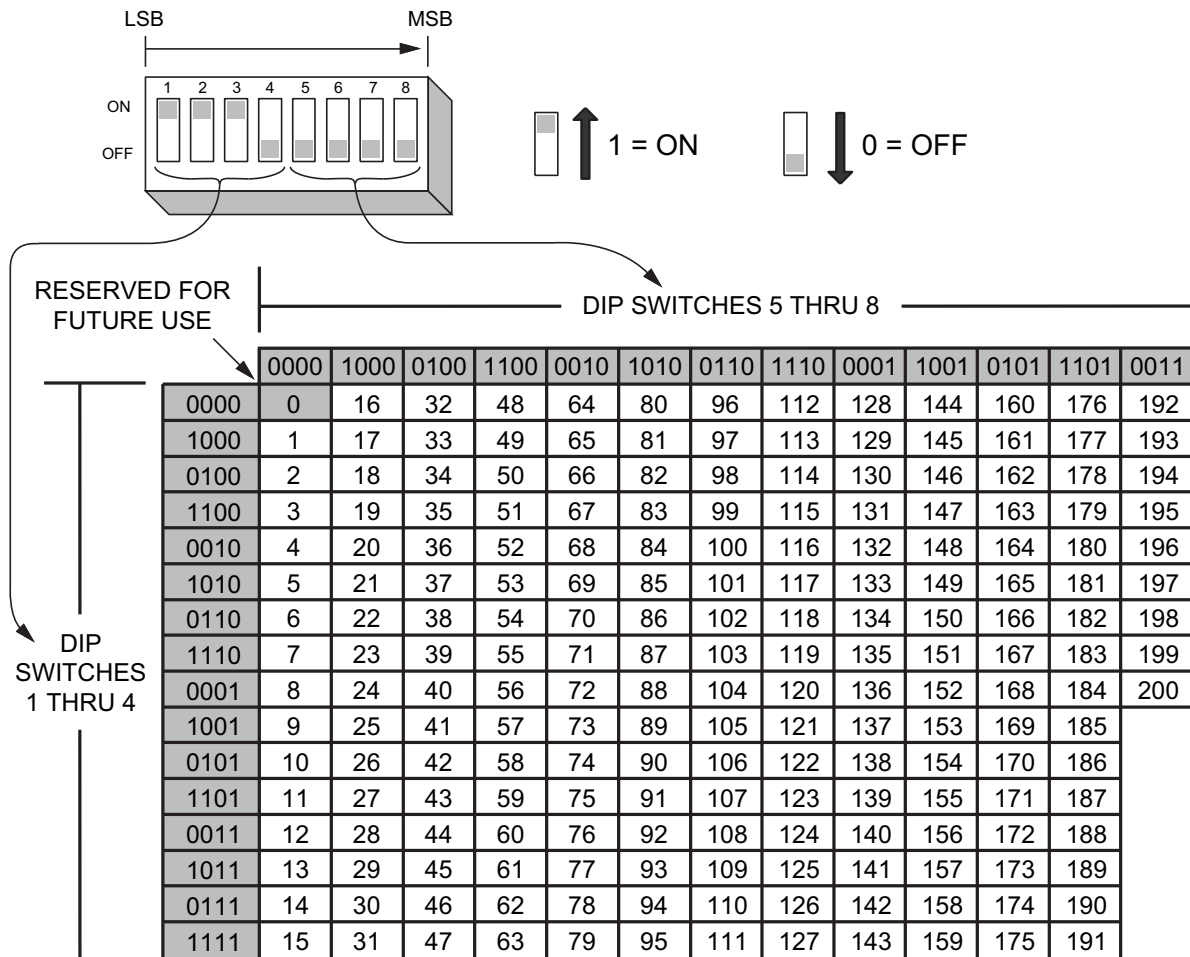

Figure 2 Signal IAM Address Setting

IDNet Signal IAM Installation Instructions

Wiring

Note: Ensure that cable shields will not ground when closing the box. Use shrink tubing or high grade electrical tape to cover bare shield.

The Signal IAM provides two terminal blocks, which are described in Tables 1 and 2, below. All terminal blocks accept 12-18 AWG wire.

Table 1 TB1 Terminations

Position	Label	Description
TB1-1	+ADDR LOOP	+IDNet input (pass-through, if required)
TB1-2	-ADDR LOOP	-IDNet input (pass-through, if required)
TB1-3	ADDR LOOP SHIELD	IDNet shield
TB1-4	-SIGNAL IN	-Signal IN for audio or 0 V input for Strobes, Horns, etc.
TB1-5	+SIGNAL IN	+Signal IN for audio or +24 V input for Strobes, Horns, etc.
TB1-6	SIGNAL IN SHIELD	Input signal shield for audio applications

Table 2 TB2 Terminations

Position	Label	Description
TB2-1	SIGNAL SHIELD	SIGNAL OUT/RETURN shield for audio applications
TB2-2	+SIGNAL OUT	+ SIGNAL OUT -- Class B operation
TB2-3	-SIGNAL OUT	- SIGNAL OUT -- Class B operation
TB2-4	+SIGNAL RETURN	+ SIGNAL RETURN -- Class A operation
TB2-5	-SIGNAL RETURN	- SIGNAL RETURN -- Class A operation

Use the following two pages to wire the Signal IAM.

70.7 VRMS speaker circuit wiring distances, Class A:

70 VRMS Power		Maximum Distance in Feet (w/ max loss of 3 DB at last speaker)			
Applied	Actual	18 AWG	16 AWG	14 AWG	12 AWG
35 W	6.25 W	1000	1000	1000	1000

70.7 VRMS speaker circuit wiring distances, Class B:

70 VRMS Power		Maximum Distance in Feet (w/ max loss of 3 DB at last speaker)			
Applied	Actual	18 AWG	16 AWG	14 AWG	12 AWG
30 W	15 W	2000	2000	2000	2000

25 VRMS speaker circuit wiring distances, Class A:

25 VRMS Power		Maximum Distance in Feet (w/ max loss of 3 DB at last speaker)			
Applied	Actual	18 AWG	16 AWG	14 AWG	12 AWG
10 W	5 W	800	1000	1000	1000

25 VRMS speaker circuit wiring distances, Class B:

25 VRMS Power		Maximum Distance in Feet (w/ max loss of 3 DB at last speaker)			
Applied	Actual	18 AWG	16 AWG	14 AWG	12 AWG
10 W	5 W	1600	2000	2000	2000

NOTE: WIRING DISTANCES ARE RESTRICTED DUE TO DC SUPERVISION LIMITATIONS.

DETAIL A:
ADDRESSABLE LOOP / AUDIO
TYPICAL WIRING METHOD

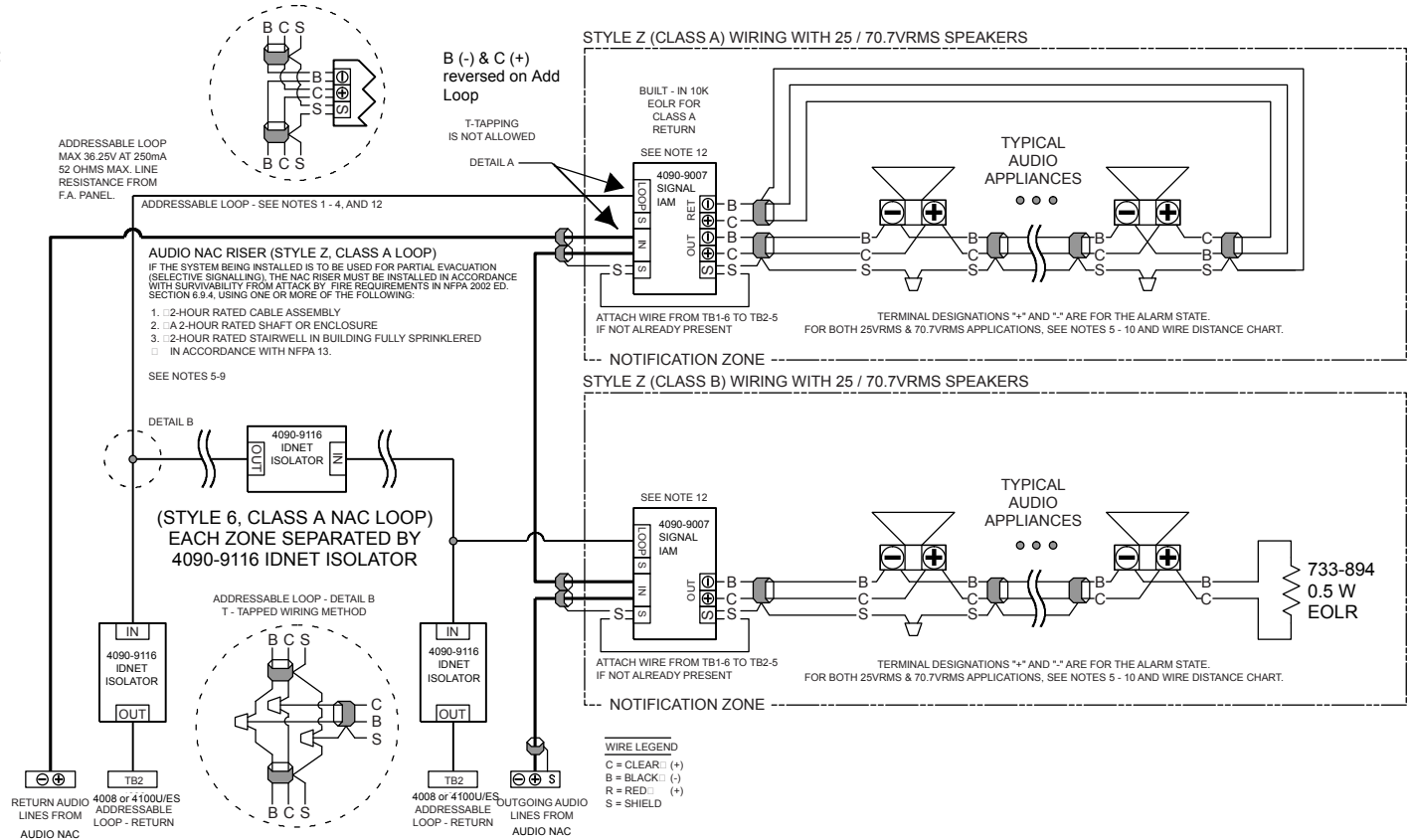

1. Addressable loop lines are 18 AWG (minimum) twisted pair.
2. Maximum allowable line run, from panel to farthest device on the addressable loop, cannot exceed 2,500 ft.
3. Maximum total wire (including all T-taps), from the panel to farthest device on the addressable loop, cannot exceed 10,000 ft.
4. Maximum number of IDNet addresses = 200. See Note 12.
5. Audio and speaker lines must be 18 AWG (minimum) twisted pair.
6. All connections must be free of grounds and stray voltages before connections are made to appliances and to the panel.
7. Max power per amplifier is 100 W at 70.7 VRMS or 50 W at 25 VRMS.
8. 70.7 and 25 VRMS speakers must be listed fire protective signaling speakers rated for 70.7 and 25 VRMS P.A. lines, respectively.
9. Total maximum power of speaker loop is 35 W at 70.7 VRMS or 12 W at 25 VRMS.
10. When computing line distances on Signal IAM output, remember to account for the wiring distance (loss) from the panel to the Signal IAM input terminals.
Note: The Signal IAM is not a NAC repeater.
11. All wiring is supervised and Power Limited unless otherwise indicated.
12. Signal IAM consumes 2 device loads on the addressable loop.
13. Refer to 4008 Front Panel Installing, Operating, and Programming Instructions (579-716) for more field wiring information as needed.

NAC wiring distances, Class A:

Maximum Distance in Feet					
Alarm Current (Amps)	18 AWG	16 AWG	14 AWG	12 AWG	Line Resistance (Ohms)
0.25	400	650	1000	1000	12
0.50	200	325	500	800	6

NAC wiring distances, Class B:

Maximum Distance in Feet					
Alarm Current (Amps)	18 AWG	16 AWG	14 AWG	12 AWG	Line Resistance (Ohms)
0.25	800	1300	2000	2000	12
0.50	400	650	1000	1600	6

NOTE: WIRING DISTANCES ARE RESTRICTED DUE TO DC SUPERVISION LIMITATIONS

DETAIL A:
ADDRESSABLE LOOP / NAC
TYPICAL WIRING METHOD

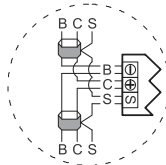

ADDRESSABLE LOOP
MAX. 36.25V AT 250mA
52 OHMS MAX. LINE
RESISTANCE FROM
F.A. PANEL.

ADDRESSABLE LOOP - SEE NOTES 1 - 4, AND 12

NAC RISER (STYLE Z, CLASS A LOOP)

Note: If the System being installed is to be used for Partial Evacuation (Selective Signalling), the NAC Riser must be installed in accordance with Survivability from attack by Fire Requirements in NFPA 2002 ED, Section 6.9.4, using one or more of the following:

1. 2-HOUR RATED CABLE ASSEMBLY
2. A 2-HOUR RATED STAIR OR ENCLOSURE
3. 2-HOUR RATED STAIRWELL IN BUILDING FULLY SPRINKLERED
- IN ACCORDANCE WITH NFPA 13.

SEE NOTES 5-9

DETAIL B



(STYLE 6, CLASS A NAC LOOP)
EACH ZONE SEPARATED BY
4090-9116 IDNET ISOLATOR

ADDRESSABLE LOOP - DETAIL B
T-TAPPED WIRING METHOD

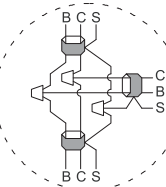

Supervised NAC
4008 or 4100U
A+ / A- OUT

ADDRESSABLE
LOOP - RETURN

ADDRESSABLE
LOOP - OUT

Supervised NAC
4008 or 4100U
B+ / B- OUT

Notes:

1. B(-) & C(+) reversed on Add Loop.
 2. Shield not used with NAC wiring.
- T-TAPPING IS NOT ALLOWED

DETAIL A

NOTIFICATION APPLIANCE CIRCUIT, STYLE Z (CLASS A) WIRING

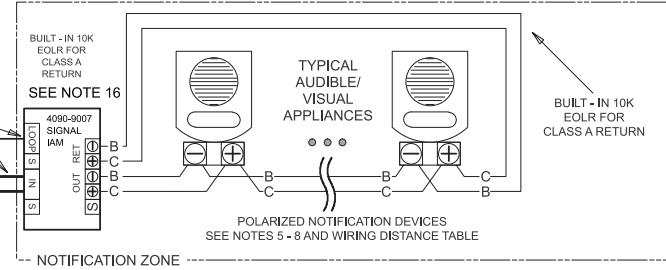

NOTIFICATION APPLIANCE CIRCUIT, STYLE Y (CLASS B) WIRING

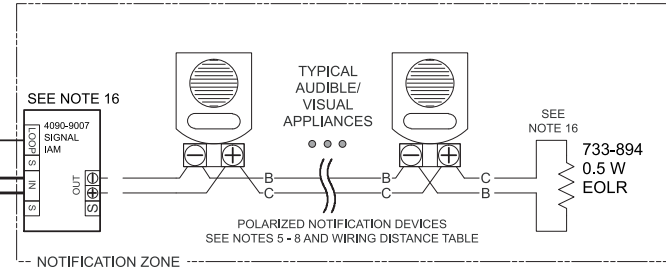

WIRE LEGEND

- C = CLEAR (+)
- B = BLACK (-)
- R = RED (+)
- S = SHIELD

1. Addressable loop lines are 18 AWG (minimum) twisted pair.
2. Maximum allowable line run, from panel to farthest device on the addressable loop, cannot exceed 2,500 ft.
3. Maximum total wire (including all T-taps), from the panel to farthest device on the addressable loop, cannot exceed 10,000 ft.
4. Maximum number of IDNet addresses = 200. See Note 13.
5. All connections must be free of grounds and stray voltages before connections are made to appliances and to the panel.
6. Total maximum power of NAC loop is 0.50 A at 24 VDC.
7. Notification appliances are rated at regulated 24 VDC.
8. When computing line distances on Signal IAM output, remember to account for the wiring distance (loss) from the panel to the Signal IAM input terminals. **Note: The Signal IAM is not a NAC repeater.**
9. All wiring is supervised and Power Limited unless otherwise indicated.
10. If wiring is routed outside the building, use of a listed secondary protector is required. Use 2081-9044 or 2081-9028. A protector must be installed at each building exit/entrance. Each 2081-9044 adds 6 Ohms resistance at 200 mA, and significantly reduces wiring distance. Each 2081-9028 adds 0.2 Ohms wiring resistance.
11. When the Signal IAM is used with the 4905-9938 Sync Control Module (SCM), Class A operation on the SCM is not supported.
12. Max. number of SCM driven Smart Sync appliances = 0.5 divided by the current draw amperage of the appliances used.
13. Signal IAM consumes 2 device loads on an addressable loop.
14. When the Signal IAM is used with the 4905-9938 Sync Control Module (SCM), the Signal IAM must adhere to one of the following restrictions:
 - Metal conduit with end-to-end length limited to 20 ft, or
 - 4905-9938 Sync Control Module, Signal IAM and interconnecting wire must be in the same single enclosure.
15. Strobes controlled by one Signal IAM cannot be mounted in an area where they can be seen together with a strobe being controlled by another Signal IAM. This applies to Sync Control Modules, if used.
16. TrueAlert Addressable Notification Appliances are not supported.
17. Refer to 4008 Front Panel Installing, Operating, and Programming Instructions (579-716) for more field wiring information as needed.
18. NOTE: The Signal IAM is not compatible with or intended to be used with standard NAC circuits (SPS, XPS, etc.) that are configured for Smart Sync operation.

IDNet Signal IAM Installation Instructions

Mounting

To mount the Signal IAM,

1. Use two #6 screws (not supplied) to fasten the Signal IAM assembly to the extension ring or back box.
2. Use four #6 screws to fasten the cover to the Signal IAM assembly. Covers used depend on the application, as shown below.

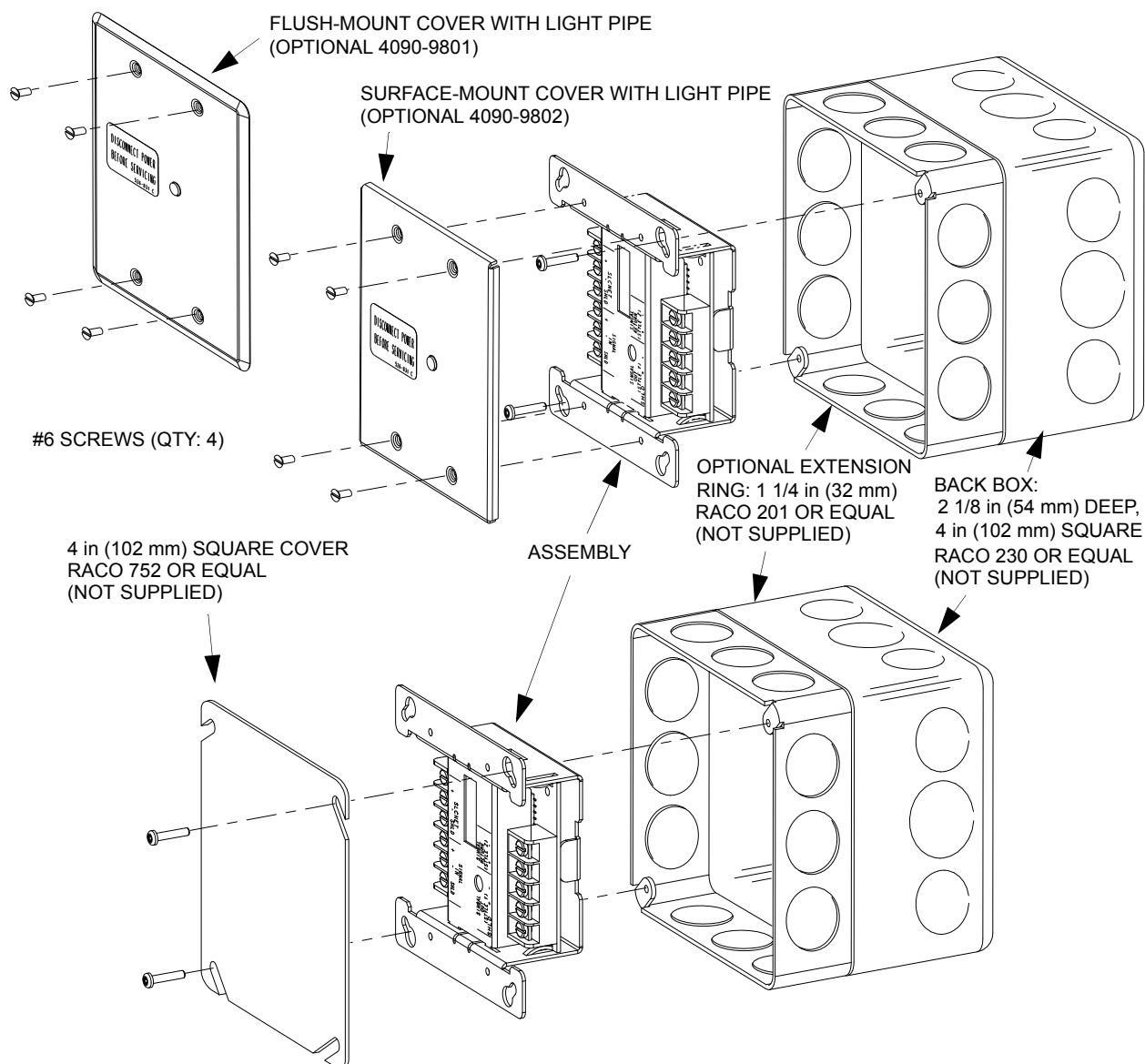

Figure 3 Signal IAM Mounting

DO NOT INSTALL ANY SIMPLEX® PRODUCT THAT APPEARS DAMAGED. Upon unpacking your product, inspect the contents of the carton for shipping damage. If damage is apparent, immediately file a claim with the carrier and notify an authorized Simplex product supplier.

ELECTRICAL HAZARD - Disconnect electrical field power when making any internal adjustments or repairs. All repairs should be performed by a representative or authorized agent of your local Simplex product supplier.

STATIC HAZARD - Static electricity can damage components. Handle as follows:

1. Ground yourself before opening or installing components.
2. Keep uninstalled components wrapped in anti-static material at all times.

NOTE: This equipment has been tested and found to comply with the limits for a Class A digital device, pursuant to Part 15 of the FCC Rules. These limits are designed to provide reasonable protection against harmful interference when the equipment is operated in a commercial environment. This equipment generates, uses, and can radiate radio frequency energy and, if not installed and used in accordance with the instruction manual, may cause harmful interference to radio communications. Operation of this equipment in a residential area is likely to cause harmful interference in which case the user will be required to correct the interference at his own expense.